

South Bend LATHES

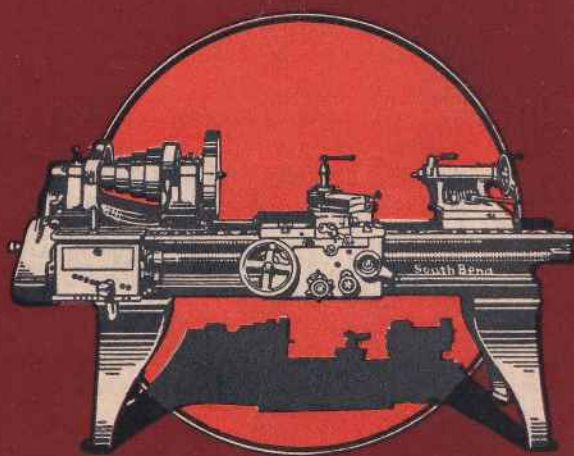

The New Model South Bend Lathe

NO 88
Catalog

SOUTH BEND LATHE WKS.
South Bend ~ ~ ~ Indiana

CONTENTS

Quick Change Gear Lathes

Countershaft Drive	Page
9-inch Quick Change Gear Lathe.....	8
11-inch Quick Change Gear Lathe.....	10
13-inch Quick Change Gear Lathe.....	12
15-inch Quick Change Gear Lathe.....	14
16-inch Quick Change Gear Lathe.....	16
18-inch Quick Change Gear Lathe.....	18
21-inch Quick Change Gear Lathe.....	20
24-inch Quick Change Gear Lathe.....	22

Standard Change Gear Lathes

Countershaft Drive	Page
9-inch Standard Change Gear Lathe...	9
11-inch Standard Change Gear Lathe...	11
13-inch Standard Change Gear Lathe...	13
15-inch Standard Change Gear Lathe...	15
16-inch Standard Change Gear Lathe...	17
18-inch Standard Change Gear Lathe...	19
21-inch Standard Change Gear Lathe ..	21
24-inch Standard Change Gear Lathe...	23

Motor Driven Lathes

Silent Chain Motor Driven Lathe, Quick Change Gear and Standard Change Gear.....	26 to 29
Simplex Motor Driven Bench Lathe, Quick Change Gear and Standard Change Gear.....	31
Self Contained Unit Motor Drive Bench Lathe, Quick Change Gear and Standard Change Gear	32
Wall Type Simplex Motor Drive for South Bend Lathes.....	68

Bench Lathes

Bench Quick Change Gear Lathes, 9-inch, 11-inch and 13-inch, Countershaft Drive.....	30
Bench Standard Change Gear Lathes, 9-inch, 11-inch and 13-inch, Countershaft Drive.....	30
Simplex Motor Driven Bench Lathe, Quick Change Gear and Standard Change Gear.....	31
Self Contained Motor Drive Bench Lathe, Quick Change Gear and Standard Change Gear..	32

Tool Room Lathes

Tool Room Lathes, Countershaft Drive, 11-inch, 13-inch and 16-inch.....	24
Tool Room Lathes, Silent Chain Motor Drive, 11-inch, 13-inch and 16-inch.....	25

Gap Bed Lathes

Gap Bed Lathe, Quick Change Gear and Standard Change Gear Types, Countershaft Drive..	34-35
Gap Bed Lathe, Quick Change Gear and Standard Change Gear, Silent Chain Motor Drive...	29

9-inch Junior Lathes

9-inch Junior Bench Lathe, Countershaft Drive.....	52
9-inch Junior Lathe, Floor Legs, Countershaft Drive	53
9-inch Junior Self Contained Motor Drive Bench Lathe Unit.....	54
9-inch Junior Silent Chain Motor Drive Lathe, Floor Legs.....	55
9-inch Junior Simplex Motor Drive Bench Lathe.....	56
9-inch Special Turning Bench Lathe, Countershaft Drive.....	57

Attachments for South Bend Lathes

Draw-in Collet Chuck with Hand Wheel... 38	Relieving Attachment..... 46
Draw-in Collet Chuck with Hand Lever... 40	Double Tool Slides..... 47
Split Collets for Draw-in Collet Chuck... 39	Raising Blocks for Lathes..... 47
Step Chuck and Closer for Draw-in Chuck.. 39	Metric Transposing Gears for Lathes..... 47
Taper Attachment..... 41	Turnstile Turret for Lathes..... 48
Milling and Keyway Cutting Attachments.42-43	Tool Post Turret and Hand Lever Turret.. 49
Cabinet Legs for Lathes..... 45	Grinding Attachments for Lathes.....50-51
Oil Pan and Pump for Lathes..... 45	Piston Adapter and Reamers..... 58
Thread Indicator..... 46	Mica Undercutters..... 59
Micrometer Carriage Stop..... 46	Hard Maple Bench for Bench Lathes..... 57

Chucks, Tools and Accessories for South Bend Lathes

Independent Lathe Chucks..... 60	Lathe Tools and Cutter Bits.....62-64
Universal Geared Scroll Lathe Chucks..... 60	Lathe Dogs..... 64
Combination Geared Scroll Lathe Chucks.. 60	Centers, Drill Pads and Arbors..... 65
Drill Chucks and Arbors..... 61	Extra Equipment for 9-inch Junior Lathe.. 57
Fitting Chuck to Lathe..... 61	Pipe Centers and Shank..... 64
Size of Chuck for Lathe..... 61	Combination Center Drills and Countersink. 64
Milling Cutters and Arbors..... 44	Center Gauge..... 64

Export Information on South Bend Lathes.....	67
Shop Equipments for South Bend Lathes.....	66

New Model South Bend Screw Cutting Lathes

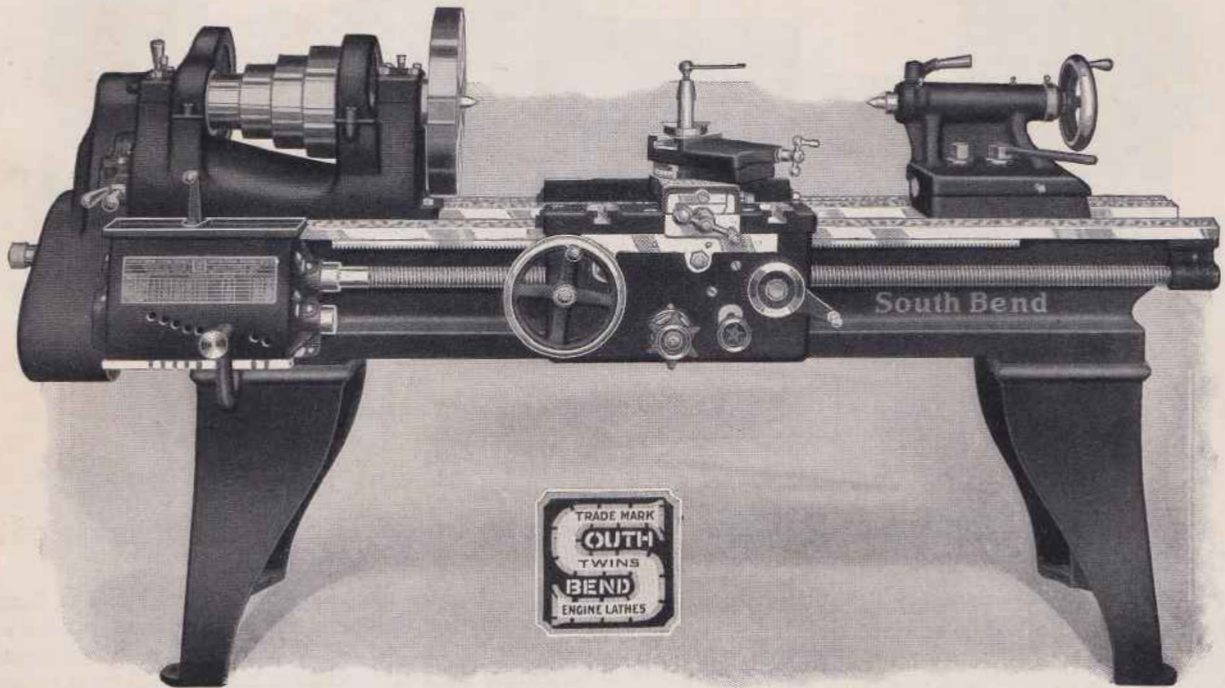

No. 88
Catalog
July - - 1927

Cable Address: "Twins, South Bend"

CODES:

Western Union Five Letter Edition,
Western Union Universal Edition,
A. B. C. Fifth Edition Improved,
Bentley's, Lieber's Standard.

South Bend Lathe Works

425 East Madison St., South Bend, Ind., U. S. A.

Printed in U. S. A.

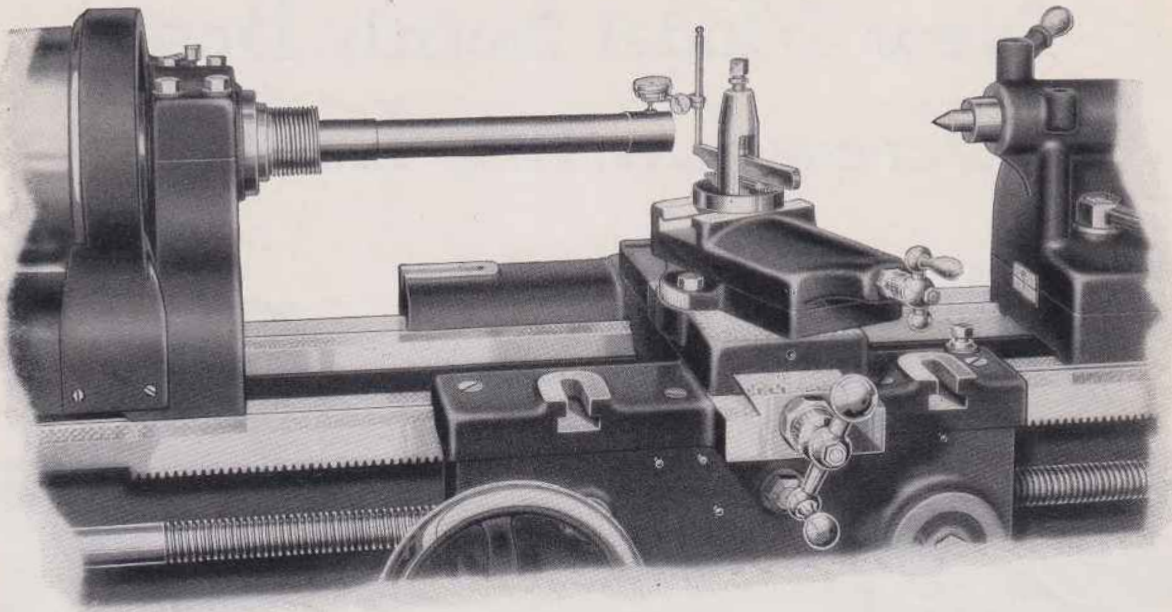

Testing Head Stock Spindle with Test Bar and Test Indicator

Sixty-four Accuracy Tests with Precision Instruments

Testing Alignment of Spindle

The illustration above shows the spindle test which is one of the 64 accuracy tests to which each South Bend Lathe is subjected. The test bar varies from 12 inches to 18 inches long, depending upon the size of the lathe. It is hardened and ground all over and fits into the taper of the spindle.

Tests Made During the Process of Manufacture

Most of the 64 accuracy tests on the South Bend Lathe are made during the process of manufacture. For example: When boring Head Stock bearings, every Head Stock is tested as it comes from the machine to see that it is bored accurately. Similar tests are made on the Tail Stock, Carriage and Saddle, etc.



Test Dial Indicator

A test dial indicator is fastened in the Tool Post. The face of this dial is so graduated that it will record an error of one ten-thousandths of an inch. Tests of this kind enable us to build lathes that are accurate in every detail.

Accuracy and Precision

We machine the various parts of each size lathe in lots of one hundred on special machines equipped with special fixtures and tools built exclusively for the making of each part. This is one of the reasons why the South Bend Lathe is so popular with the expert mechanic because he knows he can turn out his work to meet the most accurate requirements.



Testing the Cross Slide of the Saddle



Testing Large Face Plate with Dial Indicator



Machining and Hand Scraping Lathe Units

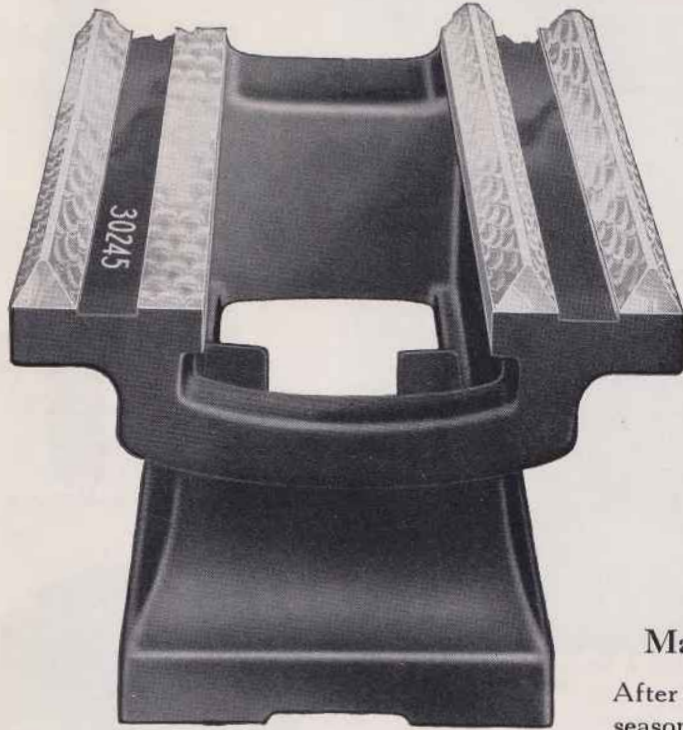

Section of Lathe Bed Showing Serial Number of Lathe

The Lathe Units for all size South Bend Lathes, such as bed, head stock, tail stock, saddle, apron, and compound rest, in addition to being machined are all hand scraped where a sliding fit is necessary.

This scraping insures accuracy, precision, durability and long life. The New Model South Bend Lathe when given proper care should last a lifetime.

The Lathe Bed is made of a hard, close grained gray iron with a semi-steel mixture which resists wear. Note the heavy cross braces which are cast in at various intervals of the bed. Three "V" ways and one flat way afford large bearing surface for the carriage, head stock and tail stock.

Machining and Seasoning Lathe Beds

After rough machining, the lathe beds are thoroughly seasoned, then they are finish machined and hand scraped.



Scraping Bronze Bearings

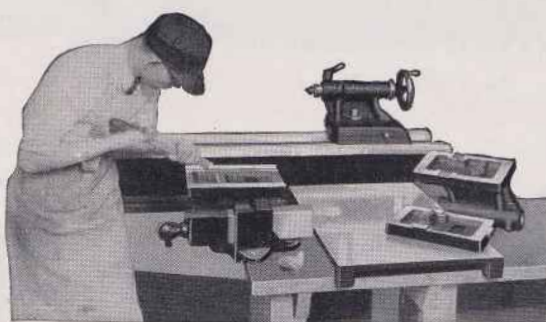

Scraping Tail Stock Base to Lathe Bed



Scraping Saddle to Lathe Bed

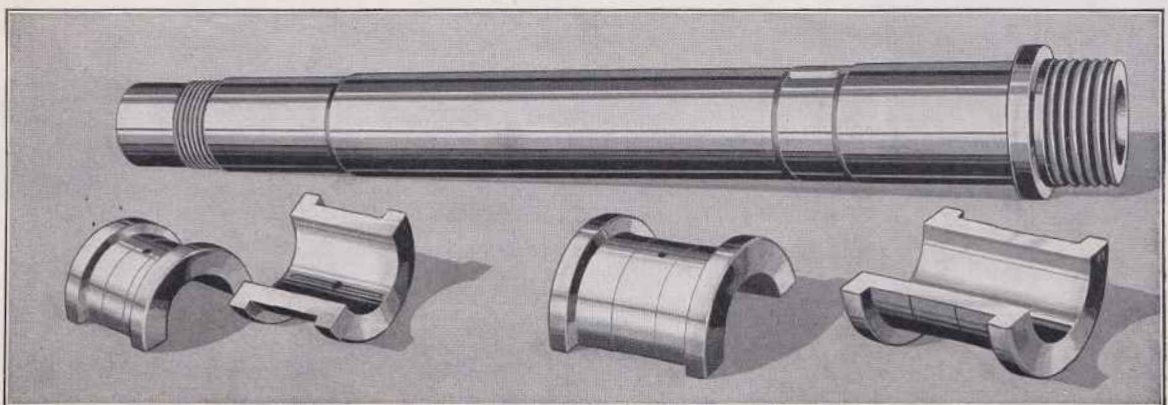

Steel Head Stock Spindle and Phosphor Bronze Bearings

Samples of Screw Threads Cut on the New Model South Bend Lathe



Thread Gauge



Tap

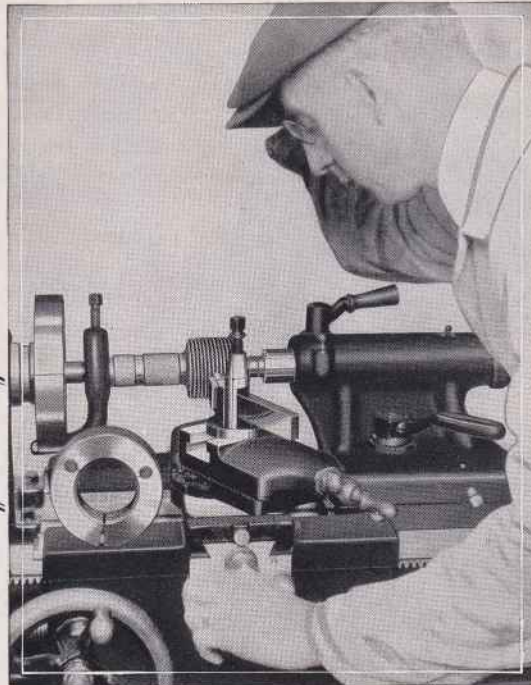

Cutting a Screw Thread



Tap



Thread Gauge



U. S. Standard Thread



Internal U. S. Standard Thread



A Nut with Internal Square Thread



Right Hand Acme Double Screw Thread



Left Hand Acme Screw Thread



Right Hand Double Screw Square Thread

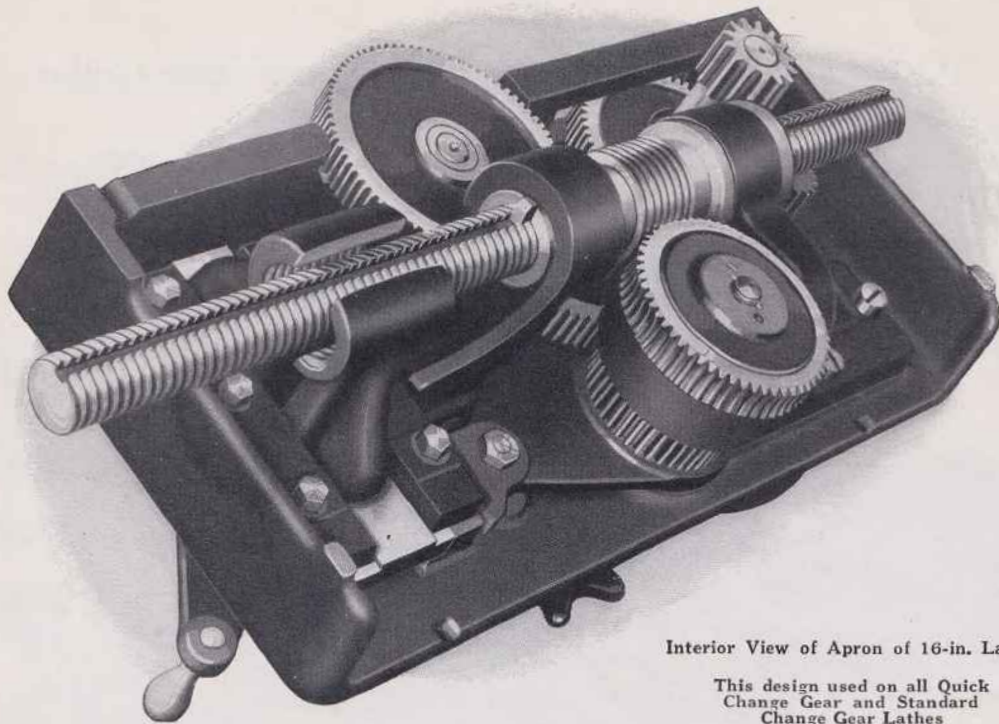

Interior View of Apron of 16-in. Lathe

This design used on all Quick
Change Gear and Standard
Change Gear Lathes

The Apron of New Model South Bend Lathes

The Apron of the New Model South Bend Lathe is a marvel of power and simplicity. The above illustration of the Apron shows the double worm bracket which supports the steel worm while it is in operation. This is a valuable feature which explains the cutting power of the South Bend Lathe.

Automatic Feeds

The Lead Screw is splined which permits it to serve as a feed rod for operating the Automatic Cross Feed and Automatic Longitudinal Feed of the Lathe. See illustration of interior of the Apron.

The Splined Lead Screw makes a positive drive feed rod as it is geared direct to the spindle and permits a variety of automatic feed changes.

Automatic Safety Device

The Automatic Safety Device in the Apron prevents the Automatic Feeds from being placed in action while the split nut is clamped on the Lead Screw for cutting screw threads, and vice versa, prevents the half nuts from being clamped on the Lead Screw while either of the Automatic Feeds are in action.

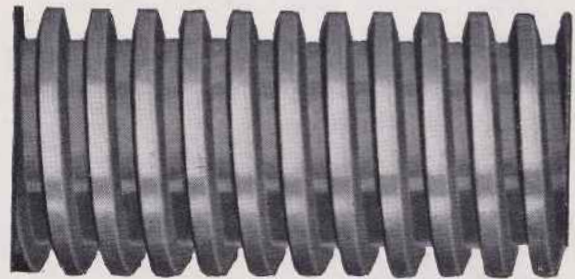

Lead Screw Acme Thread

Section of the Lead Screw for the 18-inch New Model Lathe. It is $1\frac{3}{8}$ -inch in diameter, 4 pitch—the illustration is actual size.

The New Lead Screws are made of steel, have coarse pitch Acme Thread and are cut with precision and accuracy on a special machine equipped with a Master Lead Screw. Each Lead Screw is tested for accuracy of lead, form of thread, and pitch.

The Threads of the Lead Screw are used only when cutting screw threads. The threads of the Lead Screw are not used for operating the Automatic Cross Feed or the Automatic Longitudinal Feed. The Lead Screw of the Lathe should last a lifetime.



Graduated Compound Rest with Micrometer Collar

The illustration at the right shows the Compound Rest mounted on the saddle of the Lathe, to show the advantage of the two feed screws—the compound rest screw and the cross feed screw of the saddle.

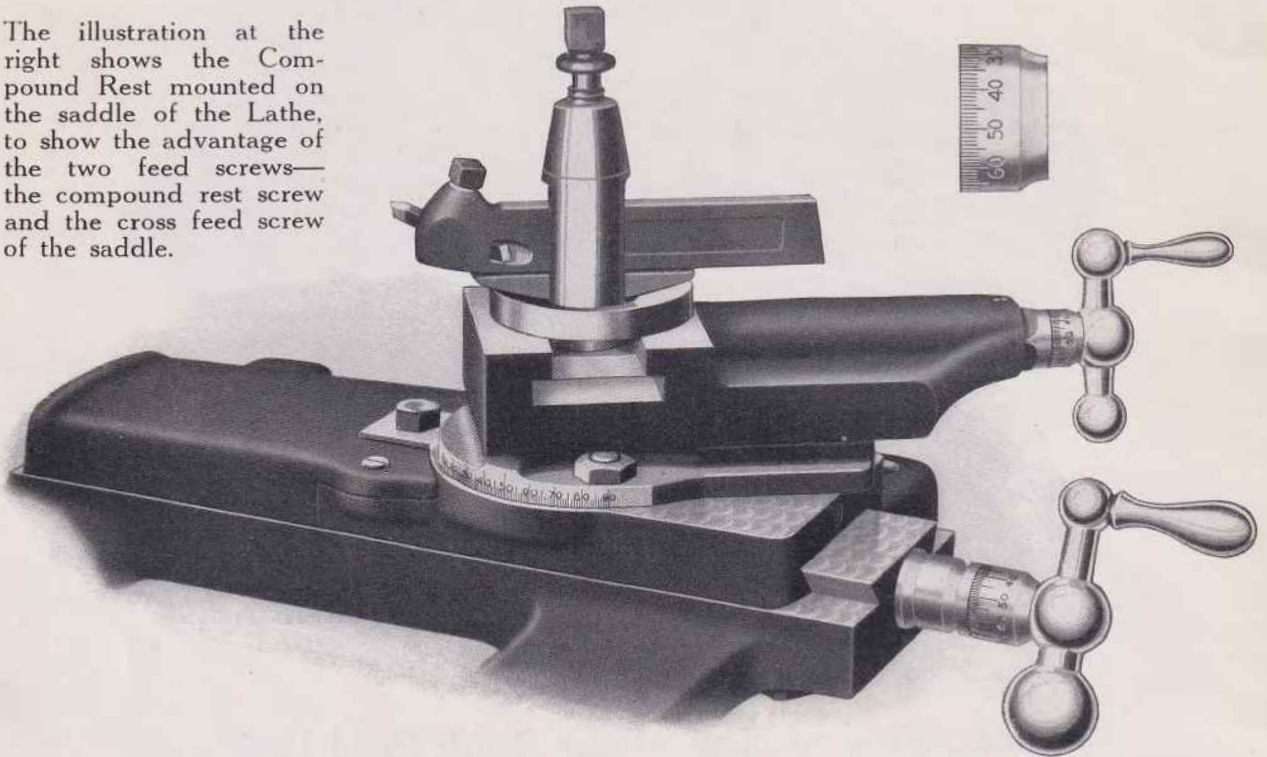

The Use of the Compound Rest

For general machine work and tool work the Compound Rest is used in turning or boring short tapers or bevels as it is graduated and can be set to feed at any angle.

The Compound Rest Screw and the Cross Feed Screw permit the operator to do all kinds of straight or taper work because in combination these two screws permit the cutting tool to be fed in any direction.

Graduated Compound Rest

The illustration shows the Compound Rest on the Saddle. The base of the Compound Rest is graduated in 180 degrees so that it can be operated at any angle on the horizontal plane.

The Compound Rest Feed Screw and the Cross Feed Screw of the Saddle are both coarse Acme Thread and each has a micrometer graduated collar reading in one-thousandths of an inch for regulating the depth of the cut.

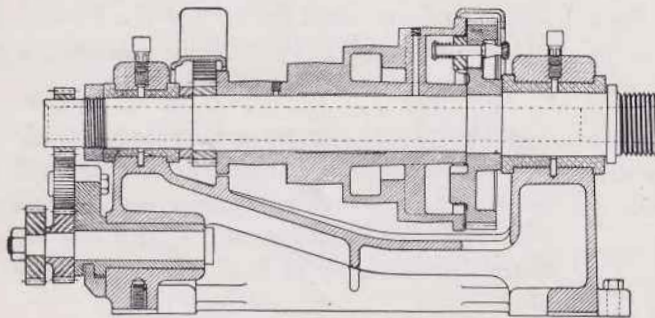

Cross Section of Headstock

The illustration above shows a cross section of the New Model Headstock and illustrates the construction of the spindle bearings, cone pulley, thrust collar, latch reverse, back gears, etc.

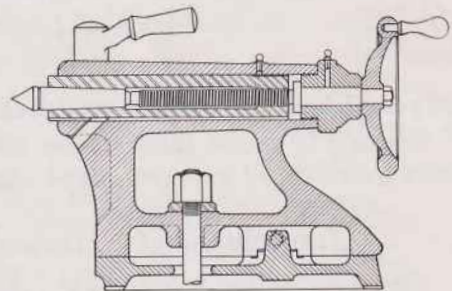

Cross Section of Tail Stock

The above illustration shows the cross section of the tail stock. The tail stock top can be set over for taper turning.



Quick Change Gear Box

On the New Model South Bend Lathes

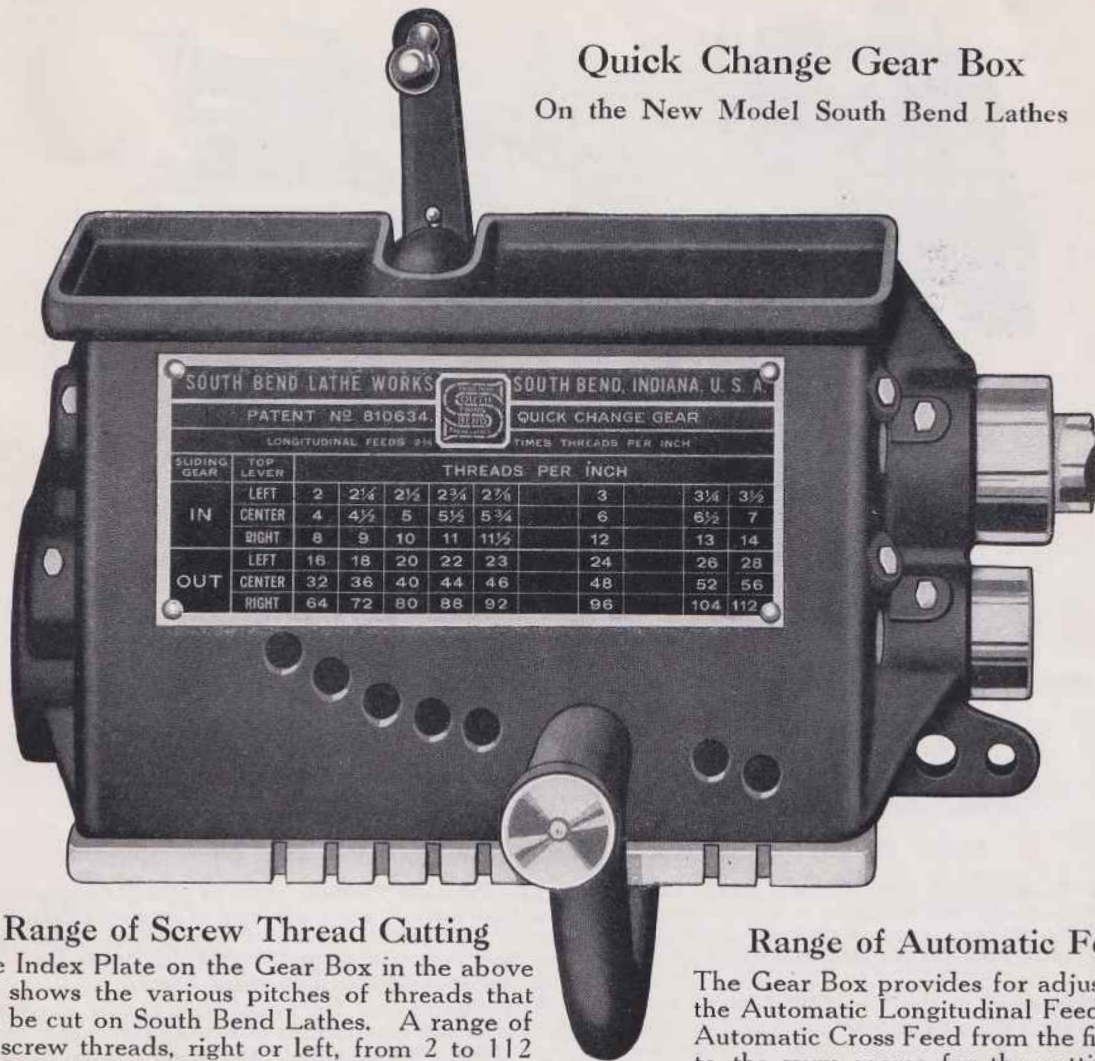

Range of Screw Thread Cutting

The Index Plate on the Gear Box in the above cut shows the various pitches of threads that can be cut on South Bend Lathes. A range of 48 screw threads, right or left, from 2 to 112 pitch, including 1 1/2 pipe thread, can be cut without removing a gear. One of these metal Index Plates is attached to each Lathe.

Range of Automatic Feeds

The Gear Box provides for adjustment of the Automatic Longitudinal Feed and the Automatic Cross Feed from the finest feed to the very coarse for the cutting of all kinds of metals. All these feeds can be adjusted without removing a gear.

Easy to Operate

The Quick Change Gear Box of the New South Bend Lathe is one of the most complete, compact and best designed on the market. It is simple, accurate, durable and easy to operate. The operating of the Quick Change Gear Box is fully explained in the book entitled "How to Run a Lathe," which is included with the equipment.

Interior View of Gear Box

A group of eight steel gears is mounted on the center shaft, any one of which can be instantly engaged with the Lead Screw. The Tumbler Lever and the small Lever enable the operator to obtain 24 changes. By sliding the knob at the end of the lathe the number of changes is doubled, making 48 in all.

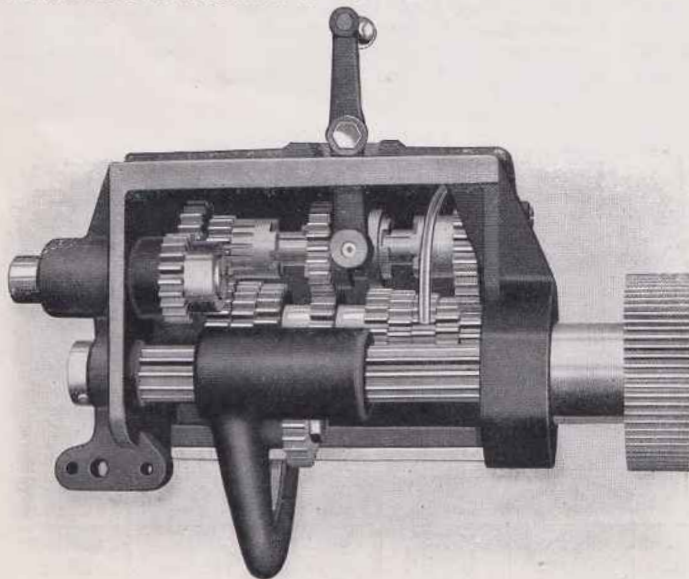

Interior View of Gear Box

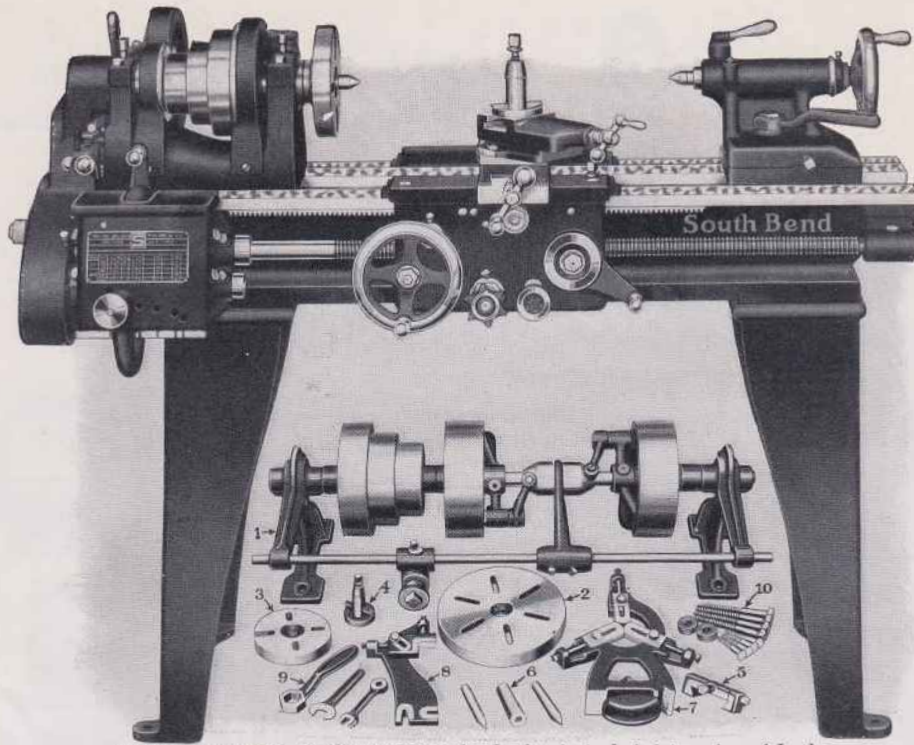

Regular equipment, as illustrated under Lathe, is included in price of Lathe

No. 82—9-inch New Model South Bend Lathe

Quick Change, Back Geared, Screw Cutting Precision Lathe

The New Model 9-inch Back Geared Quick Change Gear Screw Cutting Precision Lathe is modern in every respect and has the same features that are on the larger size lathes. It is practical for machining fine precision work.

The Workmanship of the New Model Lathe has no superior. This lathe sets a new standard for modern shop performance; a marked advance in efficiency, speed and durability. It is the result of twenty-one years experience in building lathes.

The Quick Change Gear Box provides 48 changes for cutting screw threads, right or left, from 2 to 112 per inch. See page 7 for illustration and description.

The Carriage is equipped with Automatic Longitudinal Feed, Automatic Cross Feed and Graduated Compound Rest. See pages 5 and 6.

The Practical Features such as Quick Change Gear Box, Headstock Spindle, Graduated Compound Rest, Lead Screw, Micrometer Graduated Cross Feed Collar, and Set-Over Tailstock on the New Model 9-inch lathe are illustrated and described on pages 2 to 7.

The Attachments for South Bend Lathes are listed, illustrated and described in this catalog on pages 38 to 65. These attachments permit the lathe to be fitted up for various classes of special work which is so important in up-to-date machine shop practice.

The Regular Equipment included with each 9-inch Quick Change Gear Lathe consists of: Double Friction Countershaft, Large and Small Face Plates, Tool Post Complete, Thread Cutting Stop, Two Lathe Centers and Spindle Sleeve, Center Rest, Follower Rest and Wrenches. See page 33.

Lathe Features

- Full quick change gear mechanism.
- Back geared headstock gives six spindle speeds.
- Spindle cone balanced for operating at high speeds.
- Automatic cross feed, automatic longitudinal feed.
- Hollow spindle, made of special carbon steel.
- Spring latch reverse for feeds and threads.
- Phosphor bronze spindle bearings.
- Graduated compound rest swivels to any angle.
- Tailstock is arranged for set-over for taper turning.
- Graduated collar on cross feed, compound rest screws.
- Precision lead screw for cutting accurate threads.

Lathe Specifications

- Head and Tail Spindle Centers . . . No. 2 Morse Taper
- Size of Spindle Nose 1 1/2 in. diam., 8 Threads
- Acme Lead Screw 8 Threads per inch
- Screw Thread Cutting Range 2 to 112 per inch
- Width of Cone Pulley Belt 1 in.
- Spindle Speeds 48, 78, 134, 248, 403, 714 R.P.M.
- Countershaft Speed 300 R.P.M.
- Maximum Draw-in Collet Chuck Capacity . . . 1/2 in.
- Countershaft Friction Clutch Pulleys . 6 7/8 in. x 2 1/8 in.
- Angular Travel of Compound Rest Top 2 in.
- Size of Lathe Tool Shank 11/32 in. x 13/16 in.

Net Factory Prices 9-inch Quick Change Gear Lathe Including Overhead Countershaft and Equipment

No. of Lathe	Swing Over Bed	Length of Bed	Between Centers	Hole Thru Spindle	Swing Over Carriage	Power Required	Weight Crated	Code Word	Price F.O.B. South Bend
82-X	9 1/4 in.	2 1/2 ft.	11 in.	3/4 in.	6 3/8 in.	1/4 H.P.	470 lbs.	Babit	\$265.00
82-Y	9 1/4 in.	3 ft.	18 in.	3/4 in.	6 3/8 in.	1/4 H.P.	490 lbs.	Beeke	270.00
82-Z	9 1/4 in.	3 1/2 ft.	23 in.	3/4 in.	6 3/8 in.	1/4 H.P.	510 lbs.	Bikes	275.00
82-A	9 1/4 in.	4 ft.	29 in.	3/4 in.	6 3/8 in.	1/4 H.P.	530 lbs.	Blody	280.00
82-R	9 1/4 in.	4 1/2 ft.	36 in.	3/4 in.	6 3/8 in.	1/4 H.P.	550 lbs.	Bosco	285.00

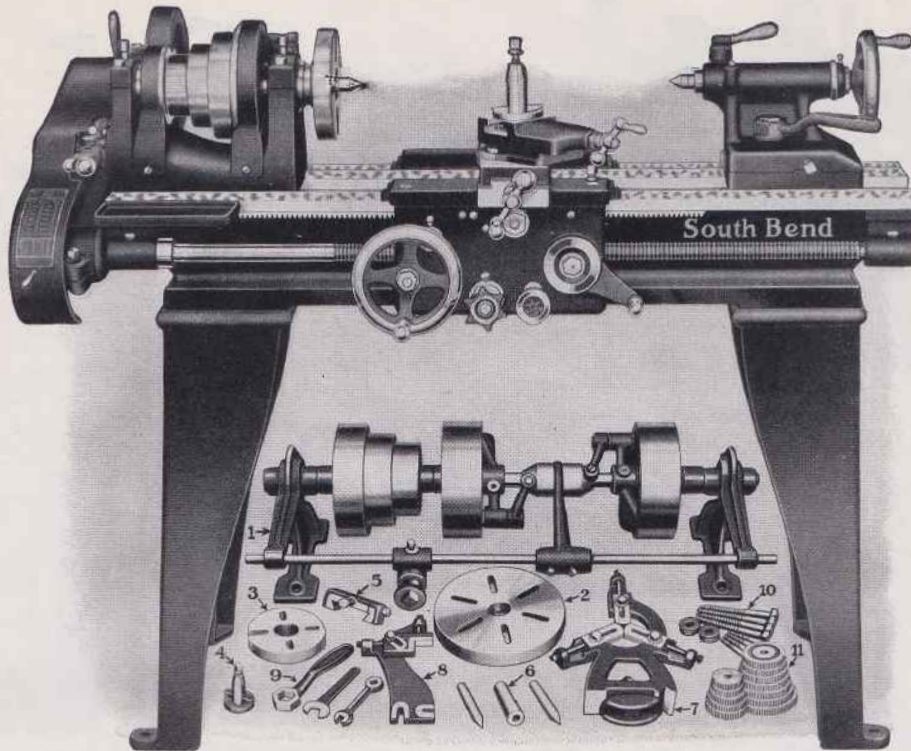

Regular equipment, as illustrated under Lathe, is included in price of Lathe

No. 31—9-inch New Model South Bend Lathe

Standard Change, Back Geared, Screw Cutting Precision Lathe

The New Model 9-inch Back Geared Standard Change Gear Screw Cutting Precision Lathe is modern in every respect and has the same features that are on the larger size lathes. It is practical for machining fine precision work.

The Workmanship of the New Model Lathe has no superior. This Lathe sets a new standard for modern shop performance; a marked advance in efficiency, speed and durability. It is the result of twenty-one years' experience in building lathes.

The Independent Change Gears permit cutting standard screw threads, right or left, from 4 to 40 per inch, including $1\frac{1}{2}$ pipe thread.

The Carriage is equipped with Automatic Longitudinal Feed, Automatic Cross Feed and Graduated Compound Rest. See pages 5 and 6.

The Practical Features such as Headstock Spindle, Graduated Compound Rest, Lead Screw, Micrometer Graduated Cross Feed Collar, and Set-Over Tailstock on the New Model 9-inch lathe are illustrated and described on pages 2 to 7.

The Attachments for South Bend Lathes are listed, illustrated and described in this catalog on pages 38 to 65. These attachments permit the lathe to be fitted up for various classes of special work which is so important in up-to-date machine shop practice.

The Regular Equipment included with each 9-inch Standard Change Gear Lathe consists of: Double Friction Countershaft, Set of Independent Change Gears, Large and Small Face Plates, Tool Post Complete, Thread Cutting Stop, Two Lathe Centers and Spindle Sleeve, Center Rest, Follower Rest and Wrenches. See page 33.

Lathe Features

- Independent change gears for threads and feeds.
- Back geared headstock gives six spindle speeds.
- Spindle cone balanced for operating at high speeds.
- Automatic cross feed, automatic longitudinal feed.
- Hollow spindle, made of special carbon steel.
- Spring latch reverse for feeds and threads.
- Phosphor bronze spindle bearings.
- Graduated compound rest swivels to any angle.
- Tailstock is arranged for set-over for taper turning.
- Graduated collar on cross feed, compound restscrews.
- Precision lead screw for cutting accurate threads.

Lathe Specifications

- Head and Tail Spindle Centers. . . No. 2 Morse Taper
- Size of Spindle Nose. $1\frac{1}{2}$ in. diam., 8 Threads
- Acme Lead Screw. 8 Threads per inch
- Screw Thread Cutting Range. 4 to 40 per inch
- Width of Cone Pulley Belt. 1 in.
- Spindle Speeds. . . 48, 78, 134, 248, 403 and 714 .R.P.M.
- Countershaft Speed 300 R.P.M.
- Maximum Draw-in Collet Chuck Capacity. . . $\frac{1}{2}$ in.
- Countershaft Friction Clutch Pulleys. $6\frac{7}{8}$ in. x $2\frac{1}{8}$ in.
- Angular Travel of Compound Rest Top. 2 in.
- Size of Lathe Tool Shank. $\frac{11}{16}$ in. x $\frac{11}{16}$ in.

Net Factory Prices 9-inch Standard Change Gear Lathe Including Overhead Countershaft and Equipment

No. of Lathe	Swing Over Bed	Length of Bed	Between Centers	Hole Thru Spindle	Swing Over Carriage	Power Required	Weight Crated	Code Word	Price F.O.B. South Bend
31-X	9 $\frac{1}{4}$ in.	2 $\frac{1}{2}$ ft.	11 in.	$\frac{3}{4}$ in.	6 $\frac{3}{8}$ in.	$\frac{1}{4}$ H.P.	460 lbs.	Brake	\$230.00
31-Y	9 $\frac{1}{4}$ in.	3 ft.	18 in.	$\frac{3}{4}$ in.	6 $\frac{3}{8}$ in.	$\frac{1}{4}$ H.P.	480 lbs.	Budis	235.00
31-Z	9 $\frac{1}{4}$ in.	3 $\frac{1}{2}$ ft.	23 in.	$\frac{3}{4}$ in.	6 $\frac{3}{8}$ in.	$\frac{1}{4}$ H.P.	500 lbs.	Bvest	240.00
31-A	9 $\frac{1}{4}$ in.	4 ft.	29 in.	$\frac{3}{4}$ in.	6 $\frac{3}{8}$ in.	$\frac{1}{4}$ H.P.	520 lbs.	Bwags	245.00
31-R	9 $\frac{1}{4}$ in.	4 $\frac{1}{2}$ ft.	36 in.	$\frac{3}{4}$ in.	6 $\frac{3}{8}$ in.	$\frac{1}{4}$ H.P.	540 lbs.	Bzeko	250.00

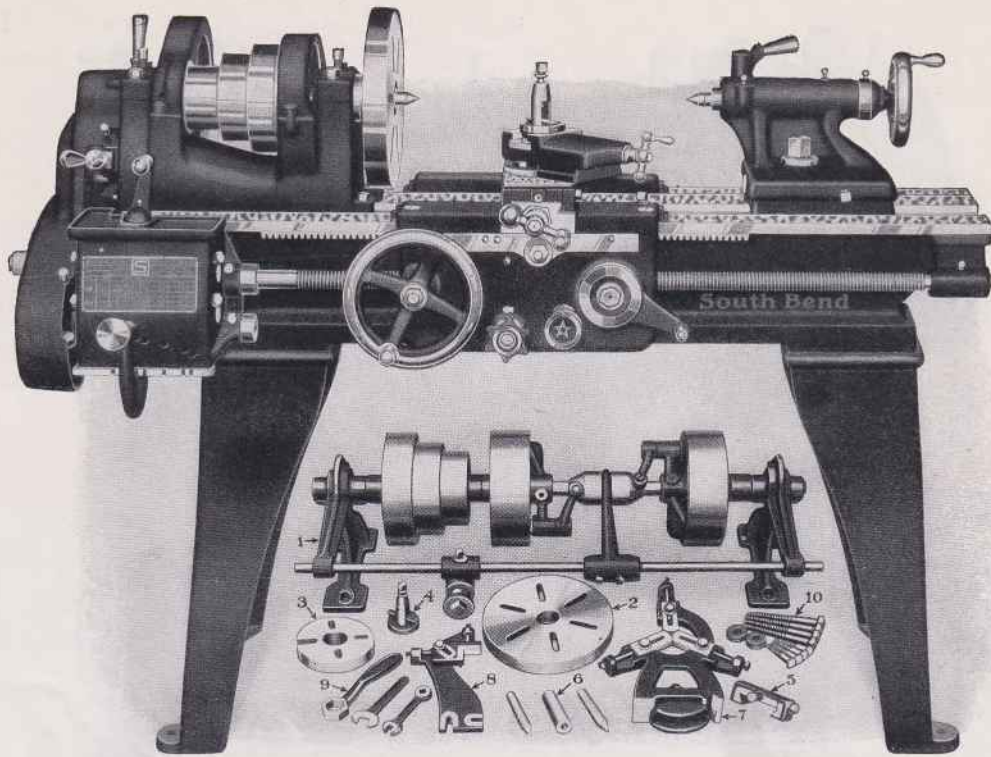

Regular equipment, as illustrated under Lathe, is included in price of Lathe

No. 84—11-inch New Model South Bend Lathe Quick Change, Back Geared, Screw Cutting Lathe

The New Model 11-inch Back Geared Quick Change Gear Screw Cutting Lathe is an excellent tool for light production work in manufacturing and fine tool work. It has the capacity for a wide variety of small machine work.

The Workmanship of the New Model Lathe has no superior. This lathe sets a new standard for modern shop performance; a marked advance in efficiency, speed and durability. It is the result of twenty-one years experience in building lathes.

The Quick Change Gear Box provides 48 changes for cutting screw threads, right or left, from 2 to 112 per inch. See page 7 for illustration and description.

The Carriage is equipped with Automatic Longitudinal Feed, Automatic Cross Feed and Graduated Compound Rest. See pages 5 and 6.

The Practical Features such as Quick Change Gear Box, Headstock Spindle, Graduated Compound Rest, Lead Screw, Micrometer Graduated Cross Feed Collar, and Set-Over Tailstock on the New Model 11-inch lathe are illustrated and described on pages 2 to 7.

The Attachments for South Bend Lathes are listed, illustrated and described in this catalog on pages 38 to 65. These attachments permit the lathe to be fitted up for various classes of special work which is so important in up-to-date machine shop practice.

The Regular Equipment included with each 11-inch Quick Change Gear Lathe consists of: Double Friction Countershaft, Large Face Plate, Small Face Plate, Tool Post Complete, Adjustable Thread Cutting Stop, Two Lathe Centers and Spindle Sleeve, Center Rest, Follower Rest and Wrenches. See page 33.

Lathe Features

- Full quick change gear mechanism.
- Back geared headstock gives six spindle speeds.
- Spindle cone balanced for operating at high speeds.
- Automatic cross feed, automatic longitudinal feed.
- Hollow spindle, made of special carbon steel.
- Spring latch reverse for feeds and threads.
- Phosphor bronze spindle bearings.
- Graduated compound rest swivels to any angle.
- Tailstock is arranged for set-over for taper turning.
- Graduated collar on cross feed, compound rest screws.
- Precision lead screw for cutting accurate threads.

Lathe Specifications

- Head and Tail Spindle Centers . . . No. 2 Morse Taper
- Size of Spindle Nose 1 5/8 in. diam., 8 Threads
- Acme Lead Screw 8 Threads per inch
- Screw Thread Cutting Range 2 to 112 per inch
- Width of Cone Pulley Belt 1 1/2 in.
- Spindle Speeds 40, 60, 100, 230, 360, 595 R.P.M.
- Countershaft Speed 290 R.P.M.
- Maximum Draw-in Collet Chuck Capacity 3/8 in.
- Countershaft Friction Clutch Pulleys . 6 7/8 in. x 2 3/8 in.
- Angular Travel of Compound Rest Top 2 3/4 in.
- Size of Lathe Tool Shank 3/8 in. x 7/8 in.

Net Factory Prices 11-inch Quick Change Gear Lathe Including Overhead Countershaft and Equipment

No. of Lathe	Swing Over Bed	Length of Bed	Between Centers	Hole Thru Spindle	Swing Over Carriage	Power Required	Weight Crated	Code Word	Price F.O.B. South Bend
84-Y	11 1/4 in.	3 ft.	12 in.	7/8 in.	7 7/8 in.	1/2 H.P.	675 lbs.	Eabot	\$325.00
84-Z	11 1/4 in.	3 1/2 ft.	18 in.	7/8 in.	7 7/8 in.	1/2 H.P.	700 lbs.	Elken	330.00
84-A	11 1/4 in.	4 ft.	24 in.	7/8 in.	7 7/8 in.	1/2 H.P.	725 lbs.	Emdor	335.00
84-B	11 1/4 in.	5 ft.	36 in.	7/8 in.	7 7/8 in.	1/2 H.P.	805 lbs.	Eolin	345.00

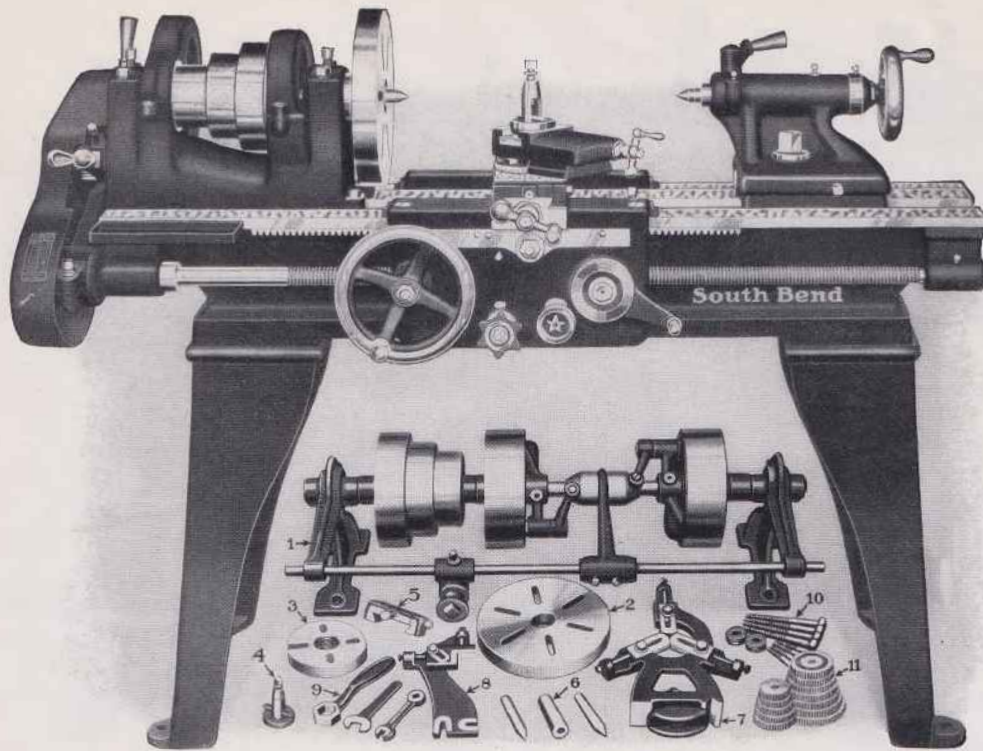

Regular equipment, as illustrated under Lathe, is included in price of Lathe

No. 33—11 inch New Model South Bend Lathe Standard Change, Back Geared, Screw Cutting Lathe

The New Model 11-inch Back Geared Standard Change Gear Screw Cutting Lathe is an excellent tool for light production work in manufacturing and fine tool work. It has the capacity for a wide variety of small machine work.

The Workmanship of the New Model Lathe has no superior. This Lathe sets a new standard for modern shop performance; a marked advance in efficiency, speed and durability. It is the result of twenty-one years' experience in building lathes.

The Independent Change Gears permit cutting standard screw threads, right or left, from 4 to 40 per inch including 1 1/2 pipe thread.

The Carriage is equipped with Automatic Longitudinal Feed, Automatic Cross Feed and Graduated Compound Rest. See pages 5 and 6.

The Practical Features such as Headstock Spindle, Graduated Compound Rest, Lead Screw, Micrometer Graduated Cross Feed Collar, and Set-Over Tailstock on the New Model 11-inch lathe are illustrated and described on pages 2 to 7.

The Attachments for South Bend Lathes are listed, illustrated and described in this catalog on pages 38 to 65. These attachments permit the lathe to be fitted up for various classes of special work which is so important in up-to-date machine shop practice.

The Regular Equipment included with each 11-inch Standard Change Gear Lathe consists of: Double Friction Countershaft, Set of Independent Change Gears, Large and Small Face Plates, Tool Post Complete, Thread Cutting Stop, Two Lathe Centers and Spindle Sleeve, Center Rest, Follower Rest and Wrenches. See page 33.

Lathe Features

- Independent change gears for threads and feeds.
- Back geared headstock gives six spindle speeds.
- Spindle cone balanced for operating at high speeds.
- Automatic cross feed, automatic longitudinal feed.
- Hollow spindle, made of special carbon steel.
- Spring latch reverse for feeds and threads.
- Phosphor bronze spindle bearings.
- Graduated compound rest swivels to any angle.
- Tailstock is arranged for set-over for taper turning.
- Graduated collar on cross feed, compound restscrews.
- Precision lead screw for cutting accurate threads.

Lathe Specifications

- Head and Tail Spindle Centers... No. 2 Morse Taper
- Size of Spindle Nose... 1 3/8 in. diam., 8 Threads
- Acme Lead Screw... 8 Threads per inch
- Screw Thread Cutting Range... 4 to 40 per inch
- Width of Cone Pulley Belt... 1 1/2 in.
- Spindle Speeds... 40, 60, 100, 230, 360, 595 R.P.M.
- Countershaft Speed... 290 R.P.M.
- Maximum Draw-in Collet Chuck Capacity... 3/8 in.
- Countershaft Friction Clutch Pulleys... 6 7/8 in. x 2 3/8 in.
- Angular Travel of Compound Rest Top... 2 3/4 in.
- Size of Lathe Tool Shank... 3/8 in. x 7/8 in.

Net Factory Prices 11-inch Standard Change Gear Lathe Including Overhead Countershaft and Equipment

No. of Lathe	Swing Over Bed	Length of Bed	Between Centers	Hole Thru Spindle	Swing Over Carriage	Power Required	Weight Crated	Code Word	Price F.O.B. South Bend
33-Y	11 1/4 in.	3 ft.	12 in.	7/8 in.	7 7/8 in.	1/2 H.P.	660 lbs.	Eazir	\$290.00
33-Z	11 1/4 in.	3 1/2 ft.	18 in.	7/8 in.	7 7/8 in.	1/2 H.P.	685 lbs.	Ebuka	295.00
33-A	11 1/4 in.	4 ft.	24 in.	7/8 in.	7 7/8 in.	1/2 H.P.	710 lbs.	Eesty	300.00
33-B	11 1/4 in.	5 ft.	36 in.	7/8 in.	7 7/8 in.	1/2 H.P.	790 lbs.	Edres	310.00

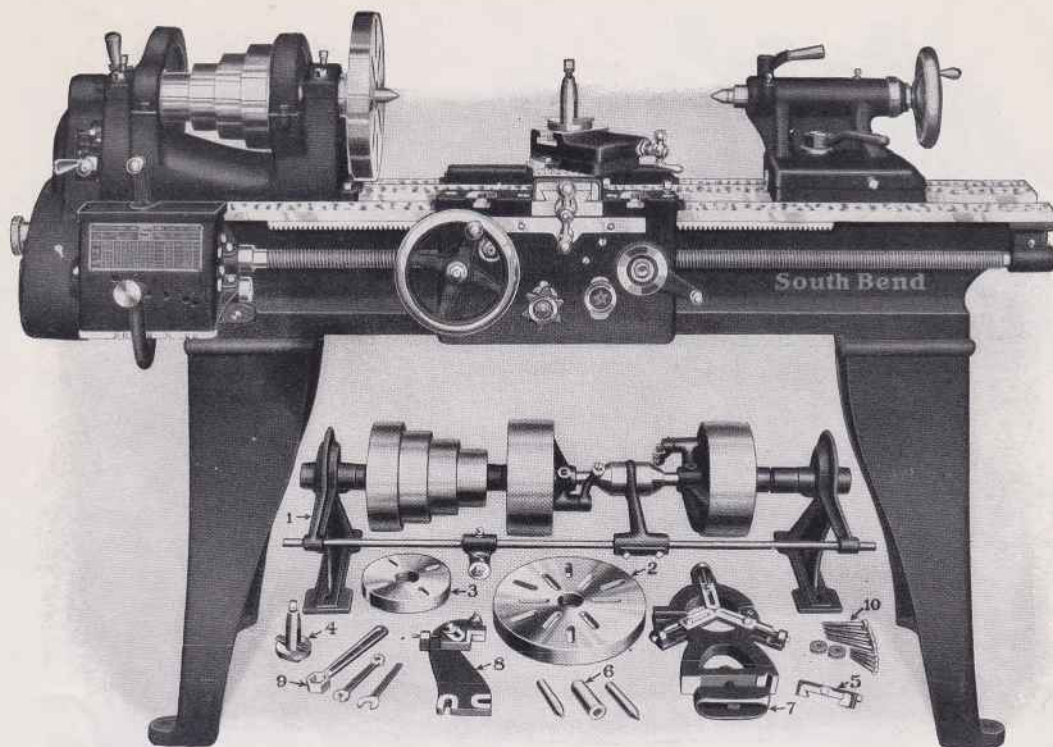

Regular equipment, as illustrated under Lathe, is included in price of Lathe

No. 86—13-inch New Model South Bend Lathe Quick Change, Back Geared, Screw Cutting Lathe

The New Model 13-inch Back Geared Quick Change Gear Screw Cutting Lathe is modern in every respect. It has the precision and accuracy for fine tool work and the capacity for a variety of accurate machine work.

The Workmanship of the New Model Lathe has no superior. This Lathe sets a new standard for modern shop performance; a marked advance in efficiency, speed and durability. It is the result of twenty-one years experience in building lathes.

The Quick Change Gear Box provides 48 changes for cutting screw threads, right or left, from 2 to 112 per inch. See page 7 for illustration and description.

The Carriage is equipped with Automatic Longitudinal Feed, Automatic Cross Feed and Graduated Compound Rest. See pages 5 and 6.

Lathe Features

- Full quick change gear mechanism.
- Back geared headstock gives eight spindle speeds.
- Spindle cone balanced for operating at high speeds.
- Automatic cross feed, automatic longitudinal feed.
- Hollow spindle, made of special carbon steel.
- Spring latch reverse for feeds and threads.
- Phosphor bronze spindle bearings.
- Graduated compound rest swivels to any angle.
- Tailstock is arranged for set-over for taper turning.
- Graduated collar on cross feed, compound rest screws.
- Precision lead screw for cutting accurate threads.

The Practical Features such as Quick Change Gear Box, Headstock Spindle, Graduated Compound Rest, Lead Screw, Micrometer Graduated Cross Feed Collar, and Set-Over Tailstock on the New Model 13-inch lathe are illustrated and described on pages 2 to 7.

The Attachments for South Bend Lathes are listed, illustrated and described in this catalog on pages 38 to 65. These attachments permit the lathe to be fitted up for various classes of special work which is so important in up-to-date machine shop practice.

The Regular Equipment included with each 13-inch Quick Change Gear Lathe consists of: Double Friction Countershaft, Large Face Plate, Small Face Plate, Tool Post Complete, Adjustable Thread Cutting Stop, Two Lathe Centers and Spindle Sleeve, Center Rest, Follower Rest and Wrenches. See page 33.

Lathe Specifications

- Head and Tail Spindle Centers . . . No. 3 Morse Taper
- Size of Spindle Nose 1 7/8 in. diam., 8 Threads
- Acme Lead Screw 6 Threads per inch
- Screw Thread Cutting Range 2 to 112 per inch
- Width of Cone Pulley Belt 1 3/4 in.
- Spindle Speeds. 25, 40, 60, 100, 180, 275, 425, 685 R.P.M.
- Countershaft Speed 275 R.P.M.
- Maximum Draw-in Collet Chuck Capacity . . . 5/8 in.
- Countershaft Friction Clutch Pulleys . . 8 in. x 2 3/8 in.
- Angular Travel of Compound Rest Top 3 1/8 in.
- Size of Lathe Tool Shank 1/2 in. x 1 1/8 in.

Net Factory Prices 13-inch Quick Change Gear Lathe Including Overhead Countershaft and Equipment

No. of Lathe	Swing Over Bed	Length of Bed	Between Centers	Hole Thru Spindle	Swing Over Carriage	Power Required	Weight Crated	Code Word	Price F.O.B. South Bend
86-A	13 1/4 in.	4 ft.	16 in.	1 in.	9 in.	3/4 H.P.	1060 lbs.	Galup	\$390.00
86-B	13 1/4 in.	5 ft.	28 in.	1 in.	9 in.	3/4 H.P.	1110 lbs.	Gehos	402.00
86-C	13 1/4 in.	6 ft.	40 in.	1 in.	9 in.	3/4 H.P.	1160 lbs.	Gifts	414.00
86-D	13 1/4 in.	7 ft.	52 in.	1 in.	9 in.	3/4 H.P.	1210 lbs.	Gobli	426.00
86-E	13 1/4 in.	8 ft.	64 in.	1 in.	9 in.	3/4 H.P.	1260 lbs.	Guaik	438.00

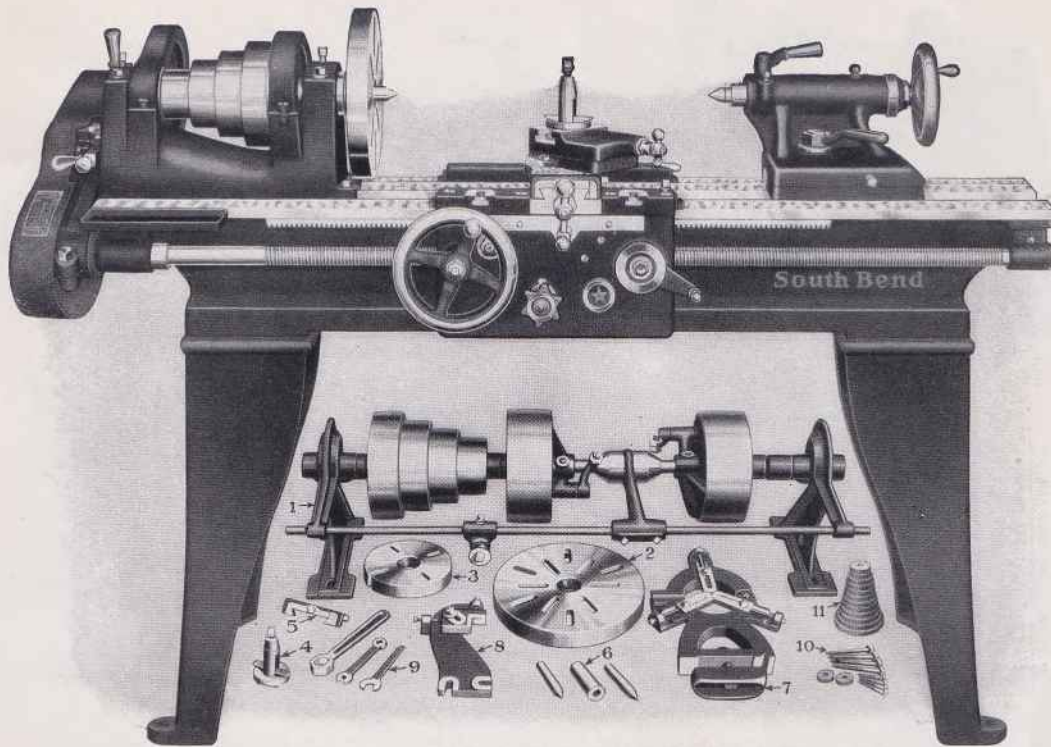

Regular equipment, as illustrated under Lathe, is included in price of Lathe

No. 35—13-inch New Model South Bend Lathe Standard Change, Back Geared, Screw Cutting Lathe

The New Model 13-inch Back Geared Standard Change Gear Screw Cutting Lathe is modern in every respect. It has the precision and accuracy for fine tool work and the capacity for a variety of accurate machine work.

The Workmanship of the New Model Lathe has no superior. This Lathe sets a new standard for modern shop performance; a marked advance in efficiency, speed and durability. It is the result of twenty-one years' experience in building lathes.

The Independent Change Gears permit cutting standard screw threads, right or left, from 4 to 40 per inch, including 1 1/2 pipe thread.

The Carriage is equipped with Automatic Longitudinal Feed, Automatic Cross Feed and Graduated Compound Rest. See pages 5 and 6.

Lathe Features

- Independent change gears for threads and feeds.
- Back geared headstock gives eight spindle speeds.
- Spindle cone balanced for operating at high speeds.
- Automatic cross feed, automatic longitudinal feed.
- Hollow spindle, made of special carbon steel.
- Spring latch reverse for feeds and threads.
- Phosphor bronze spindle bearings.
- Graduated compound rest swivels to any angle.
- Tailstock is arranged for set-over for taper turning.
- Graduated collar on cross feed, compound rest screws.
- Precision lead screw for cutting accurate threads.

The Practical Features such as Headstock Spindle, Graduated Compound Rest, Lead Screw, Micrometer Graduated Cross Feed Collar, and Set-Over Tailstock on the New Model 13-inch lathe are illustrated and described on pages 2 to 7.

The Attachments for South Bend Lathes are listed, illustrated and described in this catalog on pages 38 to 65. These attachments permit the lathe to be fitted up for various classes of special work which is so important in up-to-date machine shop practice.

The Regular Equipment included with each 13-inch Standard Change Gear Lathe consists of: Double Friction Countershaft, Set of Independent Change Gears, Large and Small Face Plates, Tool Post Complete, Thread Cutting Stop, Two Lathe Centers and Spindle Sleeve, Center Rest, Follower Rest and Wrenches. See page 33.

Lathe Specifications

- Head and Tail Spindle Centers...No. 3 Morse Taper
- Size of Spindle Nose.....1 7/8 in. diam., 8 Threads
- Acme Lead Screw.....6 Threads per inch
- Screw Thread Cutting Range.....4 to 40 per inch
- Width of Cone Pulley Belt.....1 3/4 in.
- Spindle Speeds...25, 40, 60, 100, 180, 275, 425, 685 R.P.M.
- Countershaft Speed.....275 R.P.M.
- Maximum Draw-in Collet Chuck Capacity...9/8 in.
- Countershaft Friction Clutch Pulleys...8 in. x 2 3/8 in.
- Angular Travel of Compound Rest Top...3 1/8 in.
- Size of Lathe Tool Shank.....3/2 in. x 1 1/8 in.

Net Factory Prices 13-inch Standard Change Gear Lathe Including Overhead Countershaft and Equipment

No. of Lathe	Swing Over Bed	Length of Bed	Between Centers	Hole Thru Spindle	Swing Over Carriage	Power Required	Weight Crated	Code Word	Price F.O.B. South Bend
35-A	13 1/4 in.	4 ft.	16 in.	1 in.	9 in.	3/4 H.P.	1040 lbs.	Gaget	\$340.00
35-B	13 1/4 in.	5 ft.	28 in.	1 in.	9 in.	3/4 H.P.	1090 lbs.	Geldy	352.00
35-C	13 1/4 in.	6 ft.	40 in.	1 in.	9 in.	3/4 H.P.	1140 lbs.	Gisot	364.00
35-D	13 1/4 in.	7 ft.	52 in.	1 in.	9 in.	3/4 H.P.	1190 lbs.	Goldy	376.00
35-E	13 1/4 in.	8 ft.	64 in.	1 in.	9 in.	3/4 H.P.	1240 lbs.	Guset	388.00

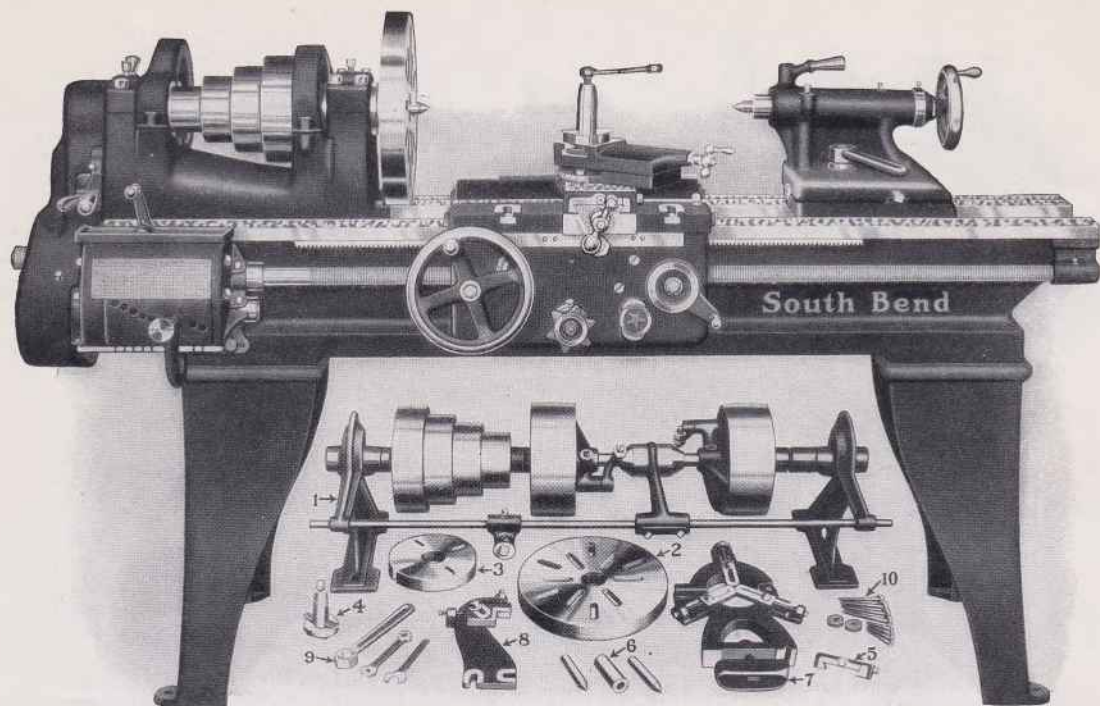

Regular equipment, as illustrated under Lathe, is included in price of Lathe

No. 88—15-inch New Model South Bend Lathe Quick Change, Back Geared, Screw Cutting Lathe

The New Model 15-inch Back Geared Quick Change Gear Screw Cutting Lathe has the power for production work in manufacturing, the precision and accuracy for fine tool work and the capacity for doing a wide variety of general machine work.

The Workmanship of the New Model Lathe has no superior. This Lathe sets a new standard for modern shop performance; a marked advance in efficiency, speed and durability. It is the result of twenty-one years' experience in building lathes.

The Quick Change Gear Box provides 48 changes for cutting screw threads, right or left, from 2 to 112 per inch. See page 7 for illustration and description.

The Carriage is equipped with Automatic Longitudinal Feed, Automatic Cross Feed and Graduated Compound Rest. See pages 5 and 6.

The Practical Features such as Quick Change Gear Box, Headstock Spindle, Graduated Compound Rest, Lead Screw, Micrometer Graduated Cross Feed Collar, and Set-Over Tailstock on the New Model 15-inch lathe are illustrated and described on pages 2 to 7.

The Attachments for South Bend Lathes are listed, illustrated and described in this catalog on pages 38 to 65. These attachments permit the lathe to be fitted up for various classes of special work which is so important in up-to-date machine shop practice.

The Regular Equipment included with each 15-inch Quick Change Gear Lathe consists of: Double Friction Countershaft, Large and Small Face Plates, Tool Post Complete, Thread Cutting Stop, Two Lathe Centers and Spindle Sleeve, Center Rest, Follower Rest and Wrenches. See page 33.

Lathe Features

- Full quick change gear mechanism.
- Back geared headstock gives eight spindle speeds.
- Spindle cone balanced for operating at high speeds.
- Automatic cross feed, automatic longitudinal feed.
- Hollow spindle, made of special carbon steel.
- Spring latch reverse for feeds and threads.
- Phosphor bronze spindle bearings.
- Graduated compound rest swivels to any angle.
- Tailstock is arranged for set-over for taper turning.
- Graduated collar on cross feed, compound restscrews.
- Precision lead screw for cutting accurate threads.

Lathe Specifications

- Head and Tail Spindle Centers . . . No. 3 Morse Taper
- Size of Spindle Nose 2 1/4 in. diam., 6 Threads
- Acme Lead Screw 6 Threads per inch
- Screw Thread Cutting Range 2 to 112 per inch
- Width of Cone Pulley Belt 2 in.
- Spindle Speeds . 22, 36, 58, 95, 160, 250, 395, 660 R.P.M.
- Countershaft Speed 250 R.P.M.
- Maximum Draw-in Collet Chuck Capacity 3/4 in.
- Countershaft Friction Clutch Pulleys . 10 in. x 3 5/8 in.
- Angular Travel of Compound Rest Top 3 3/8 in.
- Size of Lathe Tool Shank 1/2 in. x 1 1/8 in.

Net Factory Prices 15-inch Quick Change Gear Lathe Including Overhead Countershaft and Equipment

No. of Lathe	Swing Over Bed	Length of Bed	Between Centers	Hole Thru Spindle	Swing Over Carriage	Power Required	Weight Crated	Code Word	Price F.O.B. South Bend
88-B	15 1/4 in.	5 ft.	24 1/2 in.	1 1/8 in.	10 3/8 in.	1 H.P.	1475 lbs.	Latin	\$475.00
88-C	15 3/4 in.	6 ft.	36 1/2 in.	1 1/8 in.	10 3/8 in.	1 H.P.	1550 lbs.	Lemon	490.00
88-D	15 3/4 in.	7 ft.	48 1/2 in.	1 1/8 in.	10 3/8 in.	1 H.P.	1625 lbs.	Liquor	505.00
88-E	15 3/4 in.	8 ft.	60 1/2 in.	1 1/8 in.	10 3/8 in.	1 H.P.	1735 lbs.	Lower	520.00
88-G	15 3/4 in.	10 ft.	84 1/2 in.	1 1/8 in.	10 3/8 in.	1 H.P.	1900 lbs.	Lupin	550.00

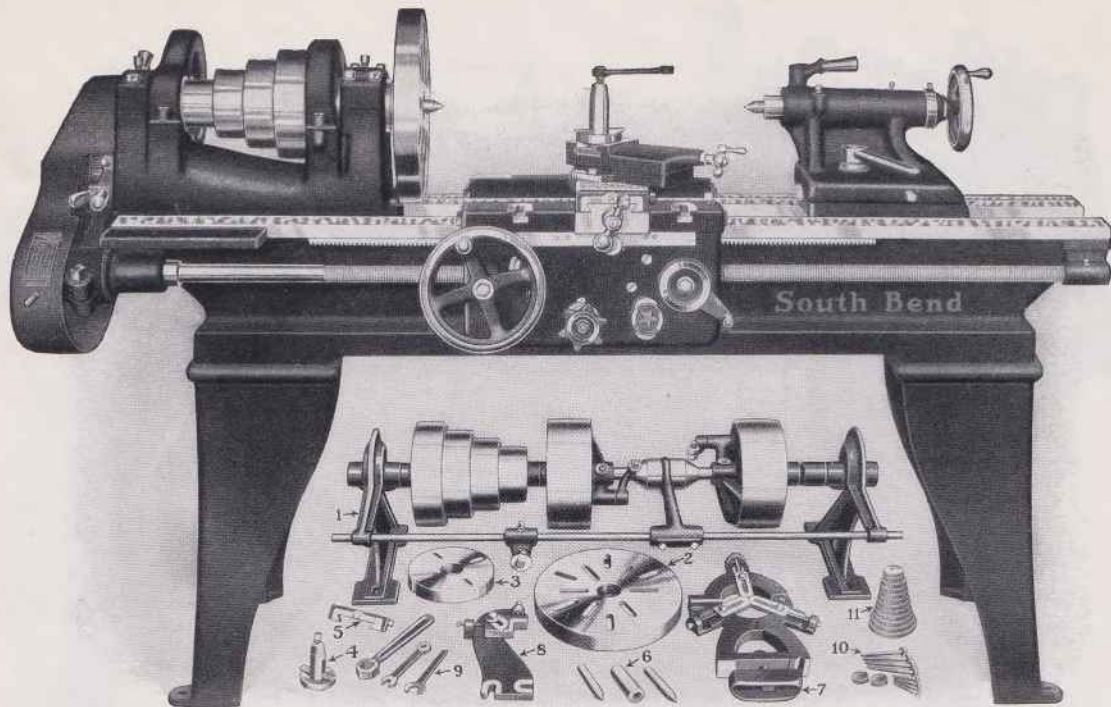

Regular equipment, as illustrated under Lathe, is included in price of Lathe

No. 39—15-inch New Model South Bend Lathe Standard Change, Back Geared, Screw Cutting Lathe

The New Model 15-inch Back Geared Standard Change Gear Screw Cutting Lathe has the power for production work in manufacturing, the precision and accuracy for fine tool work and the capacity for doing a wide variety of general machine work.

The Workmanship of the New Model Lathe has no superior. This Lathe sets a new standard for modern shop performance; a marked advance in efficiency, speed and durability. It is the result of twenty-one years' experience in building lathes.

The Independent Change Gears permit cutting standard screw threads, right or left, from 4 to 40 per inch, including 1 1/2 pipe thread.

The Carriage is equipped with Automatic Longitudinal Feed, Automatic Cross Feed and Graduated Compound Rest. See pages 5 and 6.

The Practical Features such as Headstock Spindle, Graduated Compound Rest, Lead Screw, Micrometer Graduated Cross Feed Collar, and Set-Over Tailstock on the New Model 15-inch lathe are illustrated and described on pages 2 to 7.

The Attachments for South Bend Lathes are listed, illustrated and described in this catalog on pages 38 to 65. These attachments permit the lathe to be fitted up for various classes of special work which is so important in up-to-date machine shop practice.

The Regular Equipment included with each 15-inch Standard Change Gear Lathe consists of: Double Friction Countershaft, Set of Independent Change Gears, Large and Small Face Plates, Tool Post Complete, Thread Cutting Stop, Two Lathe Centers and Spindle Sleeve, Center Rest, Follower Rest and Wrenches. See page 33.

Lathe Features

- Independent change gears for threads and feeds.
- Back geared headstock gives eight spindle speeds.
- Spindle cone balanced for operating at high speeds.
- Automatic cross feed, automatic longitudinal feed.
- Hollow spindle, made of special carbon steel.
- Spring latch reverse for feeds and threads.
- Phosphor bronze spindle bearings.
- Graduated compound rest swivels to any angle.
- Tailstock is arranged for set-over for taper turning.
- Graduated collar on cross feed, compound rest screws.
- Precision lead screw for cutting accurate threads.

Lathe Specifications

- Head and Tail Spindle Centers... No. 3 Morse Taper
- Size of Spindle Nose... 2 1/4 in. diam., 6 Threads
- Acme Lead Screw... 6 Threads per inch
- Screw Thread Cutting Range... 4 to 40 per inch
- Width of Cone Pulley Belt... 2 in.
- Spindle Speeds... 22, 36, 58, 95, 160, 250, 395, 660 R.P.M.
- Countershaft Speed... 250 R.P.M.
- Maximum Draw-in. Collet Chuck Capacity... 3/4 in.
- Countershaft Friction Clutch Pulleys... 10 in. x 3 5/8 in.
- Angular Travel of Compound Rest Top... 3 3/8 in.
- Size of Lathe Tool Shank... 1/2 in. x 1 1/8 in.

Net Factory Prices 15-inch Standard Change Gear Lathe Including Overhead Countershaft and Equipment

No. of Lathe	Swing Over Bed	Length of Bed	Between Centers	Hole Thru Spindle	Swing Over Carriage	Power Required	Weight Crated	Code Word	Price F.O.B. South Bend
39-B	15 1/4 in.	5 ft.	24 1/2 in.	1 1/8 in.	10 5/8 in.	1 H.P.	1450 lbs.	Lance	\$415.00
39-C	15 1/4 in.	6 ft.	36 1/2 in.	1 1/8 in.	10 5/8 in.	1 H.P.	1525 lbs.	Lewis	430.00
39-D	15 1/4 in.	7 ft.	48 1/2 in.	1 1/8 in.	10 5/8 in.	1 H.P.	1600 lbs.	Liver	445.00
39-E	15 1/4 in.	8 ft.	60 1/2 in.	1 1/8 in.	10 5/8 in.	1 H.P.	1710 lbs.	Lovit	460.00
39-G	15 1/4 in.	10 ft.	84 1/2 in.	1 1/8 in.	10 5/8 in.	1 H.P.	1875 lbs.	Lunar	490.00

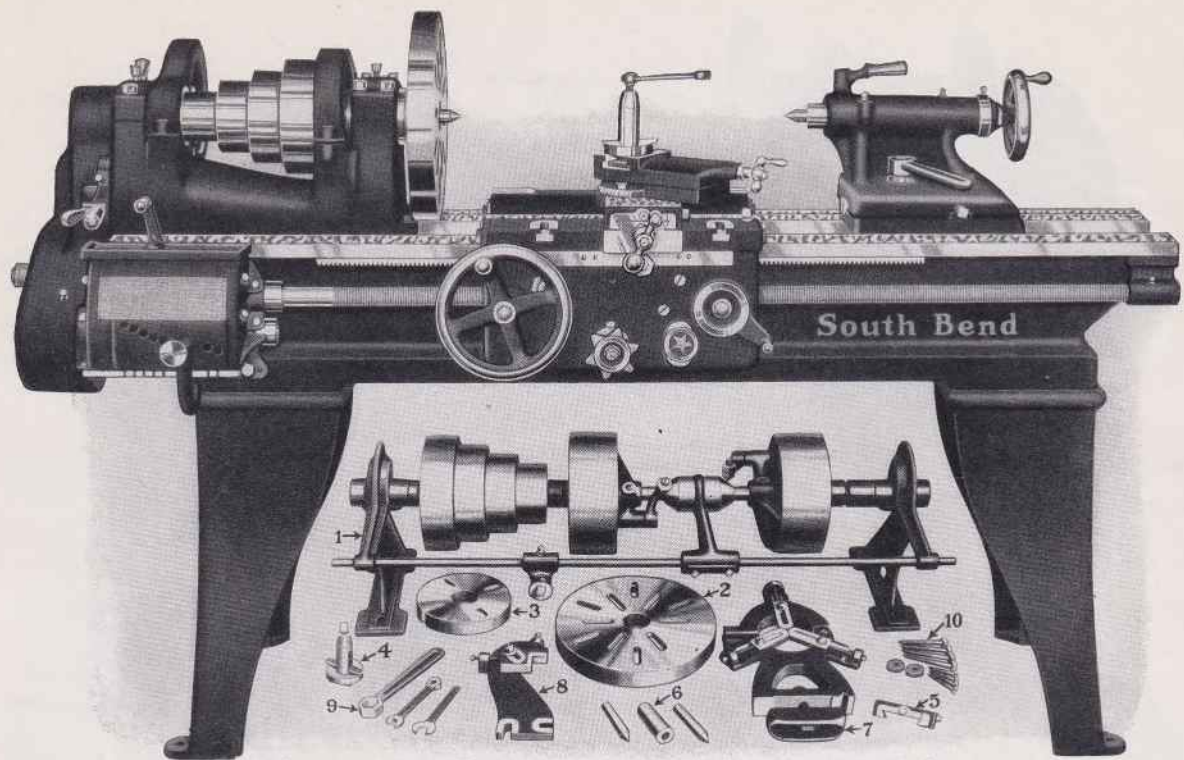

Regular equipment, as illustrated under Lathe, is included in price of Lathe

No. 92—16-inch New Model South Bend Lathe Quick Change, Back Geared, Screw Cutting Lathe

The New Model 16-inch Back Geared Quick Change Gear Screw Cutting Lathe is modern in every respect. It has the power, precision, and accuracy necessary to meet the requirements of the skilled mechanic on all kinds of manufacturing and tool work.

The Workmanship of the New Model Lathe has no superior. This Lathe sets a new standard for modern shop performance; a marked advance in efficiency, speed and durability. It is the result of twenty-one years experience in building lathes.

The Quick Change Gear Box provides 48 changes for cutting screw threads, right or left, from 2 to 112 per inch. See page 7 for illustration and description.

The Carriage is equipped with Automatic Longitudinal Feed, Automatic Cross Feed and Graduated Compound Rest. See pages 5 and 6.

Lathe Features

- Full quick change gear mechanism.
- Back geared headstock gives eight spindle speeds.
- Spindle cone balanced for operating at high speeds.
- Automatic cross feed, automatic longitudinal feed.
- Hollow spindle, made of special carbon steel.
- Spring latch reverse for feeds and threads.
- Phosphor bronze spindle bearings.
- Graduated compound rest swivels to any angle.
- Tailstock is arranged for set-over for taper turning.
- Graduated collar on cross feed, compound rest screws.
- Precision lead screw for cutting accurate threads.

The Practical Features such as Quick Change Gear Box, Headstock Spindle, Graduated Compound Rest, Lead Screw, Micrometer Graduated Cross Feed Collar, and Set-Over Tailstock on the New Model 16-inch lathe are illustrated and described on pages 2 to 7.

The Attachments for South Bend Lathes are listed, illustrated and described in this catalog on pages 38 to 65. These attachments permit the lathe to be fitted up for various classes of special work which is so important in up-to-date machine shop practice.

The Regular Equipment included with each 16-inch Quick Change Gear Lathe consists of: Double Friction Countershaft, Large Face Plate, Small Face Plate, Tool Post Complete, Adjustable Thread Cutting Stop, Two Lathe Centers and Spindle Sleeve, Center Rest, Follower Rest and Wrenches. See page 33.

Lathe Specifications

- Head and Tail Spindle Centers. No. 3 Morse Taper
- Size of Spindle Nose 2 3/8 in. diam., 6 Threads
- Acme Lead Screw 6 Threads per inch
- Screw Thread Cutting Range. 2 to 112 per inch
- Width of Cone Pulley Belt 2 1/4 in.
- Spindle Speeds 20, 30, 50, 75, 140, 225, 360, 610 R.P.M.
- Countershaft Speed 225 R.P.M.
- Maximum Draw-in Collet Chuck Capacity. 7/8 in.
- Countershaft Friction Clutch Pulleys. 10 in. x 3 3/8 in.
- Angular Travel of Compound Rest Top. 4 in.
- Size of Lathe Tool Shank. 9/8 in. x 1 3/8 in.

Net Factory Prices 16-inch Quick Change Gear Lathe Including Overhead Countershaft and Equipment

No. of Lathe	Swing Over Bed	Length of Bed	Between Centers	Hole Thru Spindle	Swing Over Carriage	Power Required	Weight Crated	Code Word	Price F.O.B. South Bend
92-C	16 1/4 in.	6 ft.	34 in.	1 3/8 in.	11 1/8 in.	1 H.P.	1875 lbs.	Malta	\$540.00
92-D	16 1/4 in.	7 ft.	46 in.	1 3/8 in.	11 1/8 in.	1 H.P.	1955 lbs.	Melbo	555.00
92-E	16 1/4 in.	8 ft.	58 in.	1 3/8 in.	11 1/8 in.	1 H.P.	2035 lbs.	Mitre	570.00
92-G	16 1/4 in.	10 ft.	82 in.	1 3/8 in.	11 1/8 in.	1 H.P.	2195 lbs.	Movir	600.00
*92-H	16 1/4 in.	12 ft.	106 in.	1 3/8 in.	11 1/8 in.	1 H.P.	2355 lbs.	Muday	645.00

*Lathe with 12-foot bed is equipped with center leg which is included in the price of the lathe.

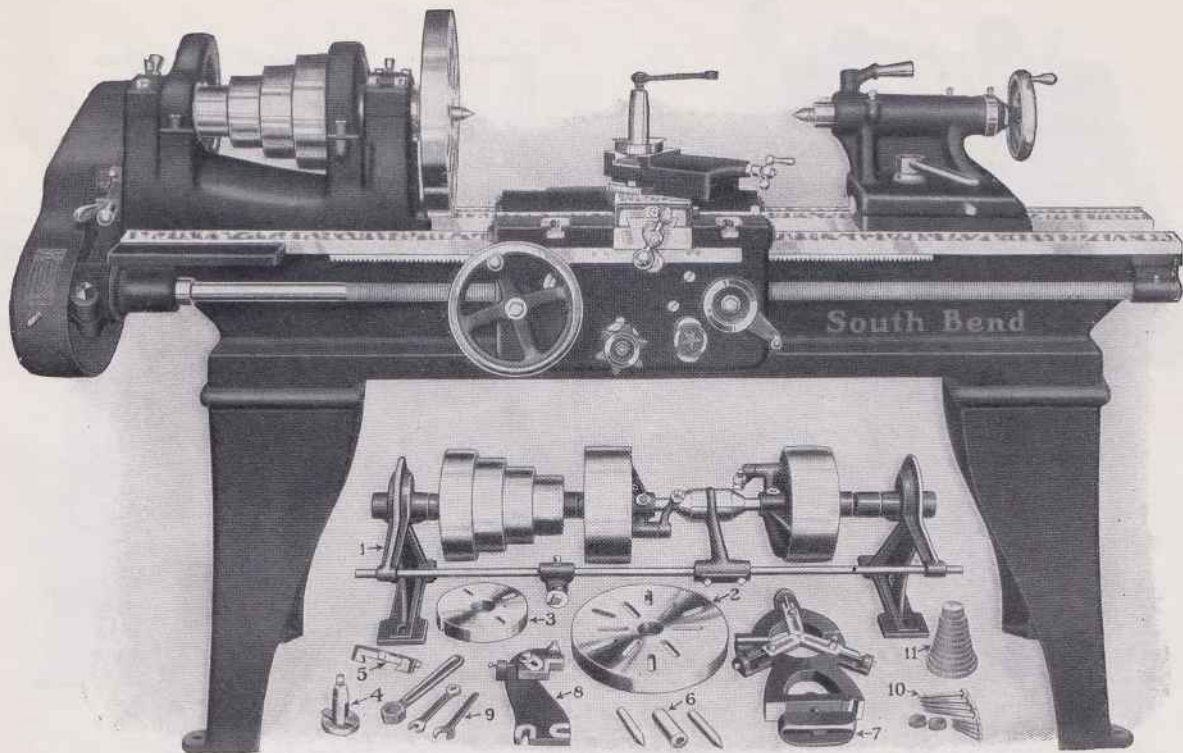

Regular equipment, as illustrated under Lathe, is included in price of Lathe

No. 41—16-inch New Model South Bend Lathe Standard Change, Back Geared, Screw Cutting Lathe

The New Model 16-inch Back Geared Standard Change Gear Screw Cutting Lathe is modern in every respect. It has the power, precision and accuracy necessary to meet the requirements of the skilled mechanic on all kinds of manufacturing and tool work.

The Workmanship of the New Model Lathe has no superior. This Lathe sets a new standard for modern shop performance; a marked advance in efficiency, speed and durability. It is the result of twenty-one years' experience in building lathes.

The Independent Change Gears permit cutting standard screw threads, right or left, from 4 to 40 per inch, including 1 1/2 pipe thread.

The Carriage is equipped with Automatic Longitudinal Feed, Automatic Cross Feed and Graduated Compound Rest. See pages 5 and 6.

The Practical Features such as Headstock Spindle, Graduated Compound Rest, Lead Screw, Micrometer Graduated Cross Feed Collar, and Set-Over Tailstock on the New Model 16-inch lathe are illustrated and described on pages 2 to 7.

The Attachments for South Bend Lathes are listed, illustrated and described in this catalog on pages 38 to 65. These attachments permit the lathe to be fitted up for various classes of special work which is so important in up-to-date machine shop practice.

The Regular Equipment included with each 16-inch Standard Change Gear Lathe consists of: Double Friction Countershaft, Set of Independent Change Gears, Large and Small Face Plates, Tool Post Complete, Thread Cutting Stop, Two Lathe Centers and Spindle Sleeve, Center Rest, Follower Rest and Wrenches. See page 33.

Lathe Features

- Independent change gears for threads and feeds.
- Back geared headstock gives eight spindle speeds.
- Spindle cone balanced for operating at high speeds.
- Automatic cross feed, automatic longitudinal feed.
- Hollow spindle, made of special carbon steel.
- Spring latch reverse for feeds and threads.
- Phosphor bronze spindle bearings.
- Graduated compound rest swivels to any angle.
- Tailstock is arranged for set-over for taper turning.
- Graduated collar on cross feed, compound restscrews.
- Precision lead screw for cutting accurate threads.

Lathe Specifications

- Head and Tail Spindle Centers... No. 3 Morse Taper
- Size of Spindle Nose... 2 3/8 in. diam., 6 Threads
- Acme Lead Screw... 6 Threads per inch
- Screw Thread Cutting Range... 4 to 40 per inch
- Width of Cone Pulley Belt... 2 1/4 in.
- Spindle Speeds... 20, 30, 50, 75, 140, 225, 360, 610 R.P.M.
- Countershaft Speed... 225 R.P.M.
- Maximum Draw-in Collet Chuck Capacity... 7/8 in.
- Countershaft Friction Clutch Pulleys... 10 in. x 3 3/8 in.
- Angular Travel of Compound Rest Top... 4 in.
- Size of Lathe Tool Shank... 5/8 in. x 1 1/8 in.

Net Factory Prices 16-inch Standard Change Gear Lathe Including Overhead Countershaft and Equipment

No. of Lathe	Swing Over Bed	Length of Bed	Between Centers	Hole Thru Spindle	Swing Over Carriage	Power Required	Weight Crated	Code Word	Price F.O.B. South Bend
41-C	16 1/4 in.	6 ft.	34 in.	1 3/8 in.	11 1/8 in.	1 H.P.	1840 lbs.	Mater	\$480.00
41-D	16 1/4 in.	7 ft.	46 in.	1 3/8 in.	11 1/8 in.	1 H.P.	1920 lbs.	Medow	495.00
41-E	16 1/4 in.	8 ft.	58 in.	1 3/8 in.	11 1/8 in.	1 H.P.	2000 lbs.	Milky	510.00
41-G	16 1/4 in.	10 ft.	82 in.	1 3/8 in.	11 1/8 in.	1 H.P.	2160 lbs.	Money	540.00
*41-H	16 1/4 in.	12 ft.	106 in.	1 3/8 in.	11 1/8 in.	1 H.P.	2320 lbs.	Mules	585.00

*Lathe with 12-foot bed is equipped with center leg which is included in price of lathe.

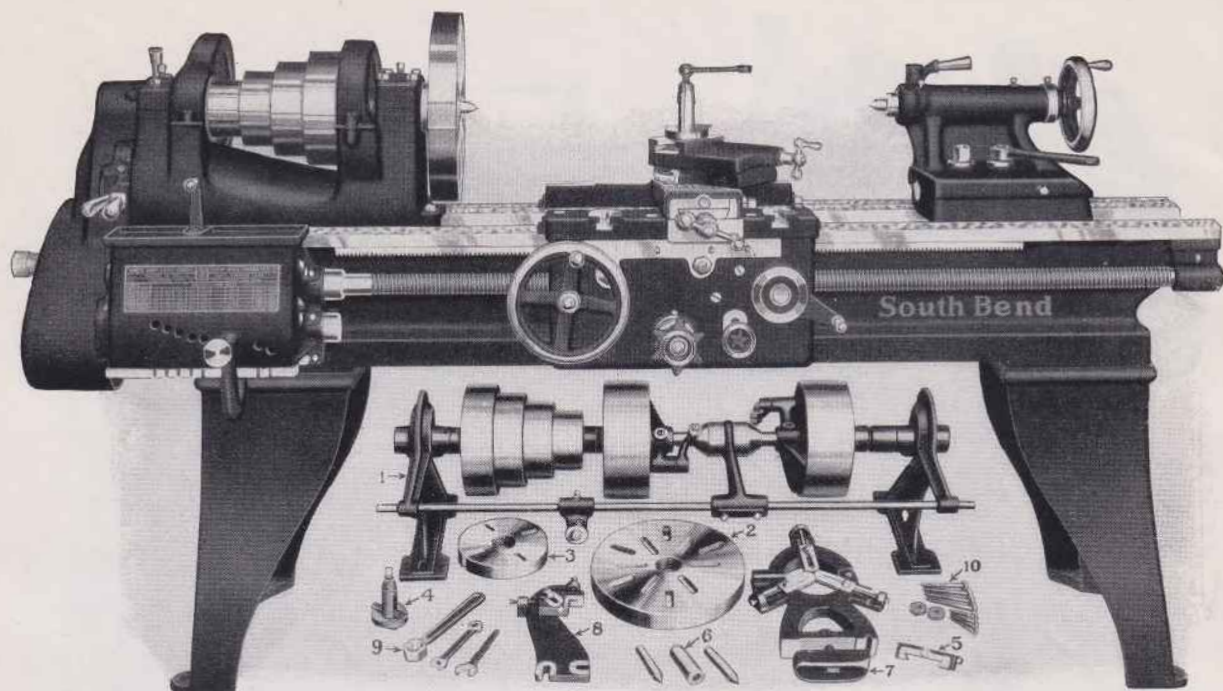

Regular equipment, as illustrated under Lathe, is included in price of Lathe

No. 94—18-inch New Model South Bend Lathe Quick Change, Back Geared, Screw Cutting Lathe

The New Model 18-inch Back Geared Quick Change Gear Screw Cutting Lathe has the power for heavy production work in manufacturing and the precision and accuracy for fine tool work. It is an excellent tool for the machine shop.

The Workmanship of the New Model Lathe has no superior. This Lathe sets a new standard for modern shop performance; a marked advance in efficiency, speed and durability. It is the result of twenty-one years experience in building lathes.

The Quick Change Gear Box provides 48 changes for cutting screw threads, right or left, from 2 to 112 per inch. See page 7 for illustration and description.

The Carriage is equipped with Automatic Longitudinal Feed, Automatic Cross Feed and Graduated Compound Rest. See pages 5 and 6.

The Practical Features such as Quick Change Gear Box, Headstock Spindle, Graduated Compound Rest, Lead Screw, Micrometer Graduated Cross Feed Collar, and Set-Over Tailstock on the New Model 18-inch lathe are illustrated and described on pages 2 to 7.

The Attachments for South Bend Lathes are listed, illustrated and described in this catalog on pages 38 to 65. These attachments permit the lathe to be fitted up for various classes of special work which is so important in up-to-date machine shop practice.

The Regular Equipment included with each 18-inch Quick Change Gear Lathe consists of: Double Friction Countershaft, Large Face Plate, Small Face Plate, Tool Post Complete, Adjustable Thread Cutting Stop, Two Lathe Centers and Spindle Sleeve, Center Rest, Follower Rest and Wrenches. See page 33.

Lathe Features

- Full quick change gear mechanism.
- Back geared headstock gives eight spindle speeds.
- Spindle cone balanced for operating at high speeds.
- Automatic cross feed, automatic longitudinal feed.
- Hollow spindle, made of special carbon steel.
- Spring latch reverse for feeds and threads.
- Phosphor bronze spindle bearings.
- Graduated compound rest swivels to any angle.
- Tailstock is arranged for set-over for taper turning.
- Graduated collar on cross feed, compound rest screws.
- Precision lead screw for cutting accurate threads.

Lathe Specifications

- Head and Tail Spindle Centers . . . No 3 Morse Taper
- Size of Spindle Nose 2 5/8 in. diam., 6 Threads
- Acme Lead Screw 4 Threads per inch
- Screw Thread Cutting Range 2 to 112 per inch
- Width of Cone Pulley Belt 2 1/2 in.
- Spindle Speeds . . 18, 28, 45, 70, 135, 200, 300, 465 R.P.M.
- Countershaft Speed 200 R.P.M.
- Maximum Draw-in Collet Chuck Capacity 1 in.
- Countershaft Friction Clutch Pulleys . 12 in. x 4 1/2 in.
- Angular Travel of Compound Rest Top 4 3/4 in.
- Size of Lathe Tool Shank 5/8 in. x 1 3/8 in.

Net Factory Prices 18-inch Quick Change Gear Lathe Including Overhead Countershaft and Equipment

No. of Lathe	Swing Over Bed	Length of Bed	Between Centers	Hole Thru Spindle	Swing Over Carriage	Power Required	Weight Crated	Code Word	Price F.O.B. South Bend
94-C	18 1/4 in.	6 ft.	29 1/2 in.	1 7/8 in.	12 5/8 in.	2 H.P.	2440 lbs.	Sapho	\$650.00
94-D	18 1/4 in.	7 ft.	41 1/2 in.	1 7/8 in.	12 5/8 in.	2 H.P.	2540 lbs.	Setra	705.00
94-E	18 1/4 in.	8 ft.	53 1/2 in.	1 7/8 in.	12 5/8 in.	2 H.P.	2640 lbs.	Sibar	700.00
94-G	18 1/4 in.	10 ft.	77 1/2 in.	1 7/8 in.	12 5/8 in.	2 H.P.	2840 lbs.	Socks	750.00
*94-H	18 1/4 in.	12 ft.	101 1/2 in.	1 7/8 in.	12 5/8 in.	2 H.P.	3140 lbs.	Subwa	815.00
*94-K	18 1/4 in.	14 ft.	125 1/2 in.	1 7/8 in.	12 5/8 in.	2 H.P.	3540 lbs.	Syogi	875.00

*Lathes with 12-foot and 14-foot beds are equipped with center leg which is included in price of lathe.

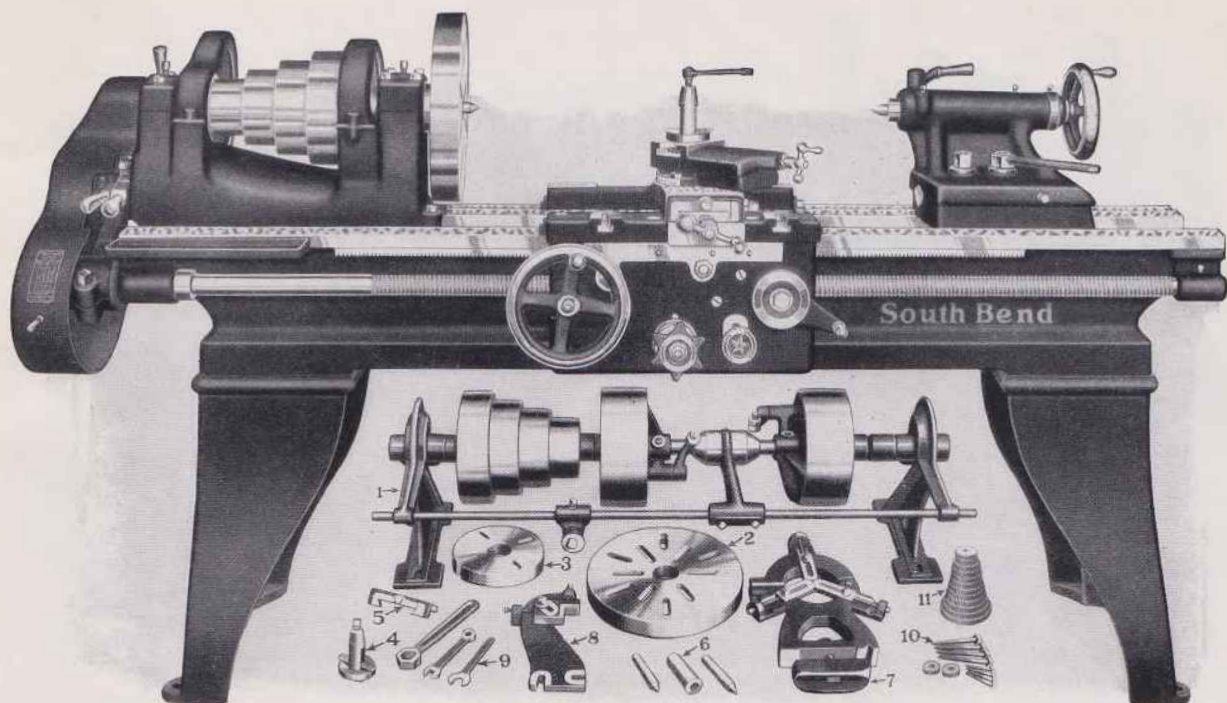

Regular equipment, as illustrated under Lathe, is included in price of Lathe

No. 43—18-inch New Model South Bend Lathe Standard Change, Back Geared, Screw Cutting Lathe

The New Model 18-inch Back Geared Standard Change Gear Screw Cutting Lathe has the power for heavy production work in manufacturing and the precision and accuracy for fine tool work. It is an excellent tool for the machine shop.

The Workmanship of the New Model Lathe has no superior. This Lathe sets a new standard for modern shop performance; a marked advance in efficiency, speed and durability. It is the result of twenty-one years' experience in building lathes.

The Independent Change Gears permit cutting standard screw threads, right or left, from 4 to 40 per inch including 11½ pipe thread.

The Carriage is equipped with Automatic Longitudinal Feed, Automatic Cross Feed and Graduated Compound Rest. See pages 5 and 6.

Lathe Features

- Independent change gears for threads and feeds.
- Back geared headstock gives eight spindle speeds.
- Spindle cone balanced for operating at high speeds.
- Automatic cross feed, automatic longitudinal feed.
- Hollow spindle, made of special carbon steel.
- Spring latch reverse for feeds and threads.
- Phosphor bronze spindle bearings.
- Graduated compound rest swivels to any angle.
- Tailstock is arranged for set-over for taper turning.
- Graduated collar on cross feed, compound restscrews.
- Precision lead screw for cutting accurate threads.

The Practical Features such as Headstock Spindle, Graduated Compound Rest, Lead Screw, Micrometer Graduated Cross Feed Collar, and Set-Over Tailstock on the New Model 18-inch lathe are illustrated and described on pages 2 to 7.

The Attachments for South Bend Lathes are listed, illustrated and described in this catalog on pages 38 to 65. These attachments permit the lathe to be fitted up for various classes of special work which is so important in up-to-date machine shop practice.

The Regular Equipment included with each 18-inch Standard Change Gear Lathe consists of: Double Friction Countershaft, Set of Independent Change Gears, Large and Small Face Plates, Tool Post Complete, Thread Cutting Stop, Two Lathe Centers and Spindle Sleeve, Center Rest, Follower Rest and Wrenches. See page 33.

Lathe Specifications

- Head and Tail Spindle Centers... No. 3 Morse Taper
- Size of Spindle Nose... 2 5/8 in. diam., 6 Threads
- Acme Lead Screw... 4 Threads per inch
- Screw Thread Cutting Range... 4 to 40 per inch
- Width of Cone Pulley Belt... 2 1/2 in.
- Spindle Speeds... 18, 28, 45, 70, 135, 200, 300, 465 R.P.M.
- Countershaft Speed... 200 R.P.M.
- Maximum Draw-in Collet Chuck Capacity... 1 in.
- Countershaft Friction Clutch Pulleys... 12 in. x 4 1/2 in.
- Angular Travel of Compound Rest Top... 4 3/4 in.
- Size of Lathe Tool Shank... 5/8 in. x 1 3/8 in.

Net Factory Prices 18-inch Standard Change Gear Lathe Including Overhead Countershaft and Equipment

No. of Lathe	Swing Over Bed	Length of Bed	Between Centers	Hole Thru Spindle	Swing Over Carriage	Power Required	Weight Crated	Code Word	Price F.O.B. South Bend
43-C	18¾ in.	6 ft.	29½ in.	1 1/8 in.	12% in.	2 H.P.	2400 lbs.	Sagah	\$585.00
43-D	18¾ in.	7 ft.	41½ in.	1 1/8 in.	12% in.	2 H.P.	2500 lbs.	Sehoe	610.00
43-E	18¾ in.	8 ft.	53½ in.	1 1/8 in.	12% in.	2 H.P.	2600 lbs.	Siati	635.00
43-G	18¾ in.	10 ft.	77½ in.	1 1/8 in.	12% in.	2 H.P.	2800 lbs.	Sombu	685.00
*43-H	18¾ in.	12 ft.	101½ in.	1 1/8 in.	12% in.	2 H.P.	3100 lbs.	Sumpt	750.00
*43-K	18¾ in.	14 ft.	125½ in.	1 1/8 in.	12% in.	2 H.P.	3500 lbs.	Sylog	810.00

*Lathes with 12-foot and 14-foot beds are equipped with center leg which is included in price of lathe.

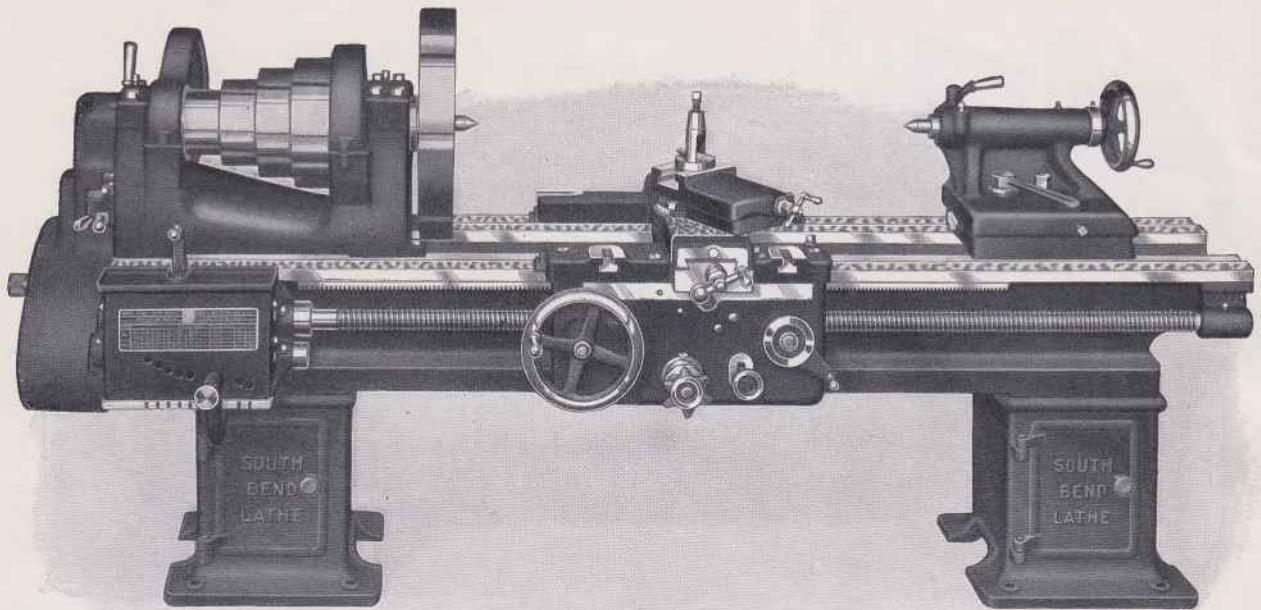

Regular equipment shown on page 33 is included in price of Lathe

No. 96—21-inch New Model South Bend Lathe Quick Change, Back Geared, Screw Cutting Lathe

The New Model 21-inch Back Geared Quick Change Gear Screw Cutting Lathe is a powerful tool built for heavy duty work in the manufacturing plant, tool room and machine shop where power, accuracy and large production are essential.

The Workmanship of the New Model Lathe has no superior. This Lathe sets a new standard for modern shop performance; a marked advance in efficiency, speed and durability. It is the result of twenty-one years experience in building lathes.

The Quick Change Gear Box provides 48 changes for cutting screw threads, right or left, from 2 to 112 per inch. See page 7 for illustration and description.

The Carriage is equipped with Automatic Longitudinal Feed, Automatic Cross Feed and Graduated Compound Rest. See pages 5 and 6.

The Practical Features such as Quick Change Gear Box, Headstock Spindle, Graduated Compound Rest, Lead Screw, Micrometer Graduated Cross Feed Collar, and Set-Over Tailstock on the New Model 21-inch lathe are illustrated and described on pages 2 to 7.

The Attachments for South Bend Lathes are listed, illustrated and described in this catalog on pages 38 to 65. These attachments permit the lathe to be fitted up for various classes of special work which is so important in up-to-date machine shop practice.

The Regular Equipment included with each 21-inch Quick Change Gear Lathe consists of: Double Friction Countershaft, Large Face Plate, Small Face Plate, Tool Post Complete, Adjustable Thread Cutting Stop, Two Lathe Centers and Spindle Sleeve, Center Rest, Follower Rest and Wrenches. See page 33.

Lathe Features

- Full quick change gear mechanism.
- Back geared headstock gives eight spindle speeds.
- Spindle cone balanced for operating at high speeds.
- Automatic cross feed, automatic longitudinal feed.
- Hollow spindle, made of special carbon steel.
- Spring latch reverse for feeds and threads.
- Phosphor bronze spindle bearings.
- Graduated compound rest swivels to any angle.
- Tailstock is arranged for set-over for taper turning.
- Graduated collar on cross feed, compound rest screws.
- Precision lead screw for cutting accurate threads.

Lathe Specifications

- Head and Tail Spindle Centers . . . No. 4 Morse Taper
- Size of Spindle Nose 3 in. diam., 5 Threads
- Acme Lead Screw 4 Threads per inch
- Screw Thread Cutting Range 2 to 112 per inch
- Width of Cone Pulley Belt 3 in.
- Spindle Speeds . . . 15, 22, 35, 55, 115, 175, 270, 430 R.P.M.
- Countershaft Speed 175 R.P.M.
- Maximum Draw-in Collet Chuck Capacity . . . 1 1/8 in.
- Countershaft Friction Clutch Pulleys . 12 in. x 4 1/2 in.
- Angular Travel of Compound Rest Top 5 3/4 in.
- Size of Lathe Tool Shank 3/4 in. x 1 5/8 in.

Net Factory Prices 21-inch Quick Change Gear Lathe Including Overhead Countershaft and Equipment

No. of Lathe	Swing Over Bed	Length of Bed	Between Centers	Hole Thru Spindle	Swing Over Carriage	Power Required	Weight Crated	Code Word	Price F.O.B. South Bend
96-D	21 1/4 in.	7 ft.	36 in.	1 1/2 in.	15 1/8 in.	3 H.P.	3490 lbs.	Tahoe	\$ 950.00
96-E	21 1/4 in.	8 ft.	48 in.	1 1/2 in.	15 1/8 in.	3 H.P.	3690 lbs.	Tegol	980.00
96-G	21 1/4 in.	10 ft.	72 in.	1 1/2 in.	15 1/8 in.	3 H.P.	3940 lbs.	Tidal	1040.00
*96-H	21 1/4 in.	12 ft.	96 in.	1 1/2 in.	15 1/8 in.	3 H.P.	4300 lbs.	Topsy	1115.00
*96-K	21 1/4 in.	14 ft.	120 in.	1 1/2 in.	15 1/8 in.	3 H.P.	4520 lbs.	Tubes	1175.00

*Lathes with 12-foot and 14-foot beds are equipped with center leg which is included in price of lathe.

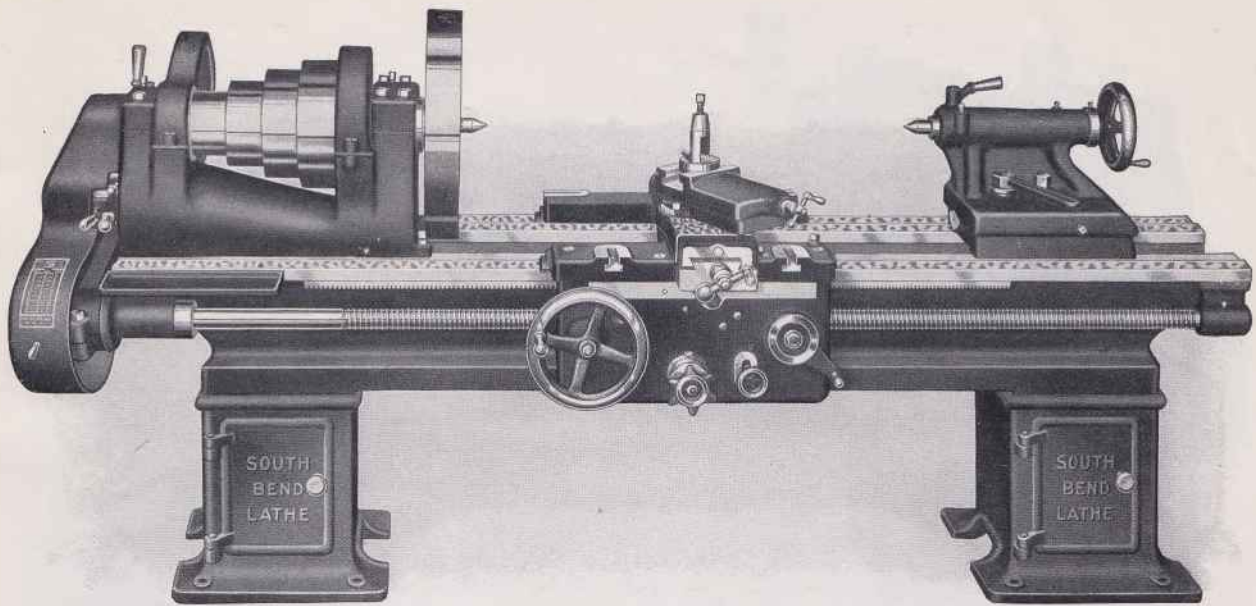

Regular equipment illustrated on page 33 is included in price of Lathe

No. 49—21-inch New Model South Bend Lathe

Standard Change, Back Geared, Screw Cutting Lathe

The New Model 21-inch Back Geared Standard Change Gear Screw Cutting Lathe is a powerful tool built for heavy duty work in the manufacturing plant, tool room and machine shop where power, accuracy and large production are essential.

The Workmanship of the New Model Lathe has no superior. This Lathe sets a new standard for modern shop performance; a marked advance in efficiency, speed and durability. It is the result of twenty-one years' experience in building lathes.

The Independent Change Gears permit cutting standard screw threads, right or left, from 4 to 40 per inch, including 1 1/2 pipe thread.

The Carriage is equipped with Automatic Longitudinal Feed, Automatic Cross Feed and Graduated Compound Rest. See pages 5 and 6.

The Practical Features such as Headstock Spindle, Graduated Compound Rest, Lead Screw, Micrometer Graduated Cross Feed Collar, and Set-Over Tailstock on the New Model 21-inch lathe are illustrated and described on pages 2 to 7.

The Attachments for South Bend Lathes are listed, illustrated and described in this catalog on pages 38 to 65. These attachments permit the lathe to be fitted up for various classes of special work which is so important in up-to-date machine shop practice.

The Regular Equipment included with each 21-inch Standard Change Gear Lathe consists of: Double Friction Countershaft, Set of Independent Change Gears, Large and Small Face Plates, Tool Post Complete, Thread Cutting Stop, Two Lathe Centers and Spindle Sleeve, Center Rest, Follower Rest and Wrenches. See page 33.

Lathe Features

- Independent change gears for threads and feeds.
- Back geared headstock gives eight spindle speeds.
- Spindle cone balanced for operating at high speeds.
- Automatic cross feed, automatic longitudinal feed.
- Hollow spindle, made of special carbon steel.
- Spring latch reverse for feeds and threads.
- Phosphor bronze spindle bearings.
- Graduated compound rest swivels to any angle.
- Tailstock is arranged for set-over for taper turning.
- Graduated collar on cross feed, compound rest screws.
- Precision lead screw for cutting accurate threads.

Lathe Specifications

- Head and Tail Spindle Centers . . . No. 4 Morse Taper
- Size of Spindle Nose 3 in. diam., 5 Threads
- Acme Lead Screw 4 Threads per inch
- Screw Thread Cutting Range 4 to 40 per inch
- Width of Cone Pulley Belt 3 in.
- Spindle Speeds . . 15, 22, 35, 55, 115, 175, 270, 430 R.P.M.
- Countershaft Speed 175 R.P.M.
- Maximum Draw-in Collet Chuck Capacity . . . 1 1/8 in.
- Countershaft Friction Clutch Pulleys. 12 in. x 4 1/2 in.
- Angular Travel of Compound Rest Top 5 3/4 in.
- Size of Lathe Tool Shank 3/4 in. x 1 5/8 in.

Net Factory Prices 21-inch Standard Change Gear Lathe Including Overhead Countershaft and Equipment

No. of Lathe	Swing Over Bed	Length of Bed	Between Centers	Hole Thru Spindle	Swing Over Carriage	Power Required	Weight Crated	Code Word	Price F.O.B. South Bend
49-D	21 3/4 in.	7 ft.	36 in.	1 1/2 in.	15 1/2 in.	3 H.P.	3450 lbs.	Taint	\$ 870.00
49-E	21 3/4 in.	8 ft.	48 in.	1 1/2 in.	15 1/2 in.	3 H.P.	3650 lbs.	Tehid	900.00
49-G	21 3/4 in.	10 ft.	72 in.	1 1/2 in.	15 1/2 in.	3 H.P.	3900 lbs.	Tired	960.00
*49-H	21 3/4 in.	12 ft.	96 in.	1 1/2 in.	15 1/2 in.	3 H.P.	4260 lbs.	Tongs	1035.00
*49-K	21 3/4 in.	14 ft.	120 in.	1 1/2 in.	15 1/2 in.	3 H.P.	4480 lbs.	Tudor	1095.00

*Lathes with 12-foot and 14-foot beds are equipped with center leg which is included in price of lathe.

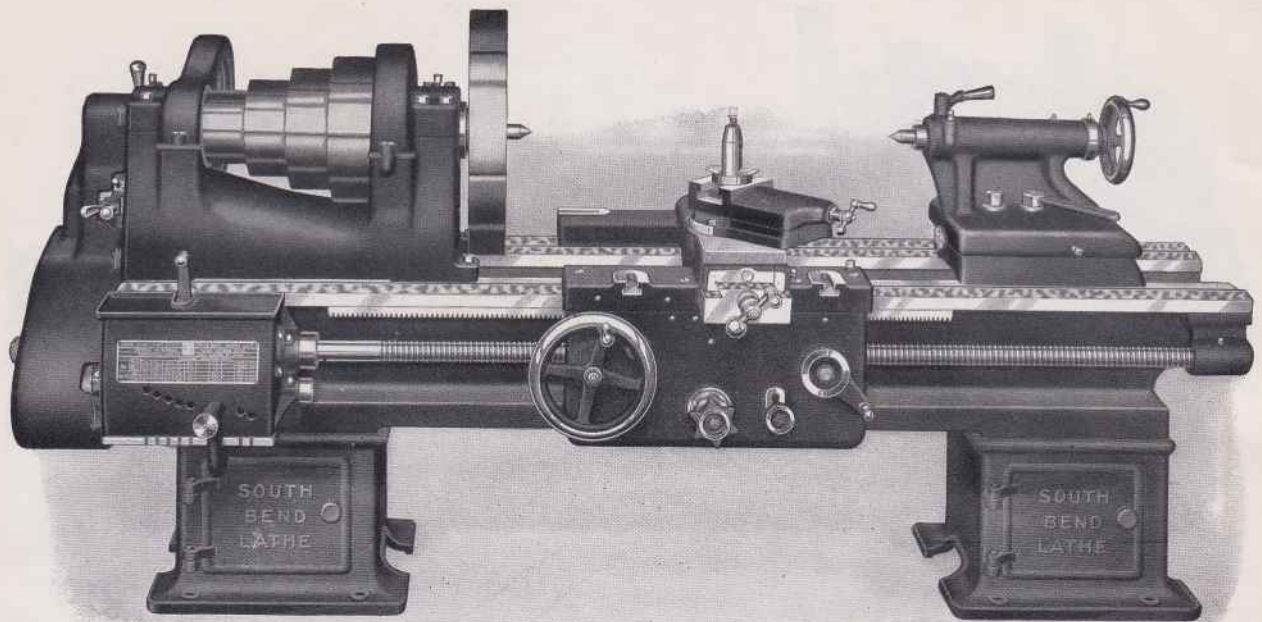

Regular equipment shown on page 33 is included in price of Lathe

No. 98—24-inch New Model South Bend Lathe

Quick Change, Back Geared, Screw Cutting Lathe

The New Model 24-inch Back Geared Quick Change Gear Screw Cutting Lathe is the largest size we build. It is a heavy, rigid tool and practical for the manufacturing plant, tool room and machine shop where power and accuracy are required.

The Workmanship of the New Model Lathe has no superior. This Lathe sets a new standard for modern shop performance; a marked advance in efficiency, speed and durability. It is the result of twenty-one years' experience in building lathes.

The Quick Change Gear Box provides 48 changes for cutting screw threads, right or left, from 2 to 112 per inch. See page 7 for illustration and description.

The Carriage is equipped with Automatic Longitudinal Feed, Automatic Cross Feed and Graduated Compound Rest. See pages 5 and 6.

The Practical Features such as Quick Change Gear Box, Headstock Spindle, Graduated Compound Rest, Lead Screw, Micrometer Graduated Cross Feed Collar, and Set-Over Tailstock on the New Model 24-inch lathe are illustrated and described on pages 2 to 7.

The Attachments for South Bend Lathes are listed, illustrated and described in this catalog on pages 38 to 65. These attachments permit the lathe to be fitted up for various classes of special work which is so important in up-to-date machine shop practice.

The Regular Equipment included with each 24-inch Quick Change Gear Lathe consists of: Double Friction Countershaft, Large Face Plate, Small Face Plate, Tool Post Complete, Adjustable Thread Cutting Stop, Two Lathe Centers and Spindle Sleeve, Center Rest, Follower Rest and Wrenches. See page 33.

Lathe Features

- Full quick change gear mechanism.
- Back geared headstock gives eight spindle speeds.
- Spindle cone balanced for operating at high speeds.
- Automatic cross feed, automatic longitudinal feed.
- Hollow spindle, made of special carbon steel.
- Spring latch reverse for feeds and threads.
- Phosphor bronze spindle bearings.
- Graduated compound rest swivels to any angle.
- Tailstock is arranged for set-over for taper turning.
- Graduated collar on cross feed, compound rest screws.
- Precision lead screw for cutting accurate threads.

Lathe Specifications

- Head and Tail Spindle Centers . . . No. 4 Morse Taper
- Size of Spindle Nose 3 1/4 in. diam., 5 Threads
- Acme Lead Screw 4 Threads per inch
- Screw Thread Cutting Range 2 to 112 per inch
- Width of Cone Pulley Belt 3 1/2 in.
- Spindle Speeds . . 10, 16, 25, 40, 100, 150, 225, 355 R.P.M.
- Countershaft Speed 150 R.P.M.
- Maximum Draw-in Collet Chuck Capacity . . . 1 3/8 in.
- Countershaft Friction Clutch Pulleys . . . 14 in. x 5 in.
- Angular Travel of Compound Rest Top 5 3/4 in.
- Size of Lathe Tool Shank 3/4 in. x 1 1/8 in.

Net Factory Prices 24-inch Quick Change Gear Lathe Including Overhead Countershaft and Equipment

No. of Lathe	Swing Over Bed	Length of Bed	Between Centers	Hole Thru Spindle	Swing Over Carriage	Power Required	Weight Crated	Code Word	Price F.O.B. South Bend
98-E	24 1/4 in.	8 ft.	43 in.	1 3/4 in.	17 3/8 in.	3 H.P.	4490 lbs.	Waked	\$1280.00
98-G	24 1/4 in.	10 ft.	67 in.	1 3/4 in.	17 3/8 in.	3 H.P.	4740 lbs.	Welch	1360.00
*98-H	24 1/4 in.	12 ft.	91 in.	1 3/4 in.	17 3/8 in.	3 H.P.	5140 lbs.	Wifot	1460.00
*98-K	24 1/4 in.	14 ft.	115 in.	1 3/4 in.	17 3/8 in.	3 H.P.	5410 lbs.	Wobly	1540.00
*98-M	24 1/4 in.	16 ft.	139 in.	1 3/4 in.	17 3/8 in.	3 H.P.	5690 lbs.	Wurah	1620.00

*Lathes with 12-foot, 14-foot and 16-foot beds are equipped with center leg which is included in price of lathe.

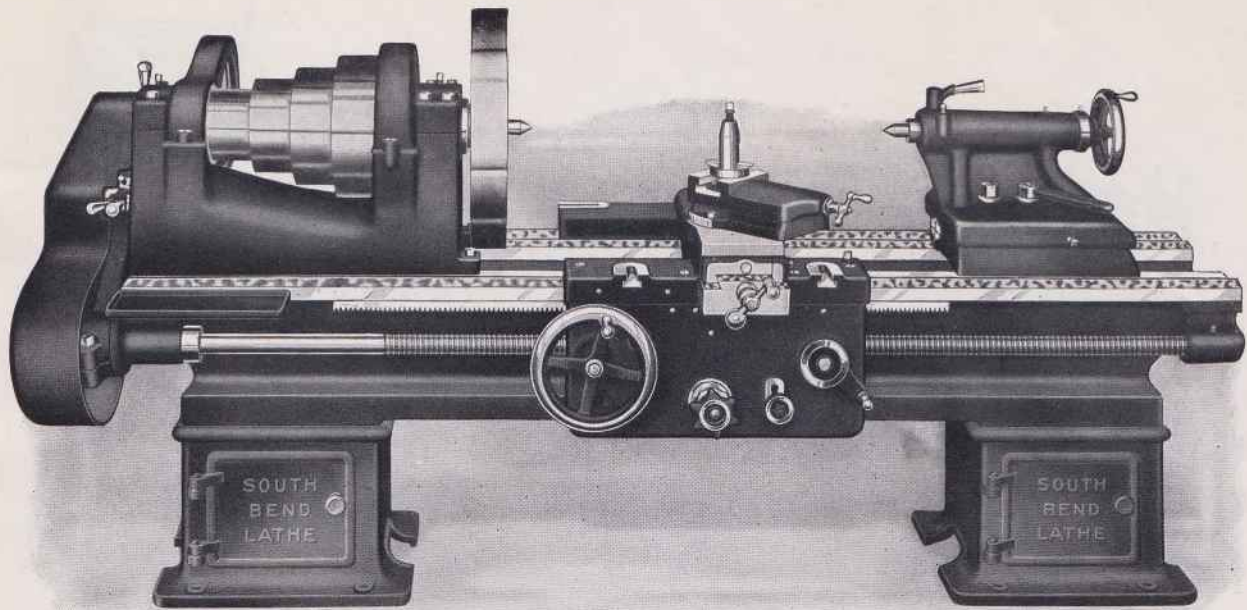

Regular equipment illustrated on page 33 is included in price of Lathe

No. 57—24-inch New Model South Bend Lathe

Standard Change, Back Geared, Screw Cutting Lathe

The New Model 24-inch Back Geared Standard Change Gear Screw Cutting Lathe is the largest size we build. It is a heavy, rigid tool and practical for the manufacturing plant, tool room and machine shop where power and accuracy are required.

The Workmanship of the New Model Lathe has no superior. This Lathe sets a new standard for modern shop performance; a marked advance in efficiency, speed and durability. It is the result of twenty-one years' experience in building lathes.

The Independent Change Gears permit cutting standard screw threads, right or left, from 4 to 40 per inch, including 1 1/2 pipe thread.

The Carriage is equipped with Automatic Longitudinal Feed, Automatic Cross Feed and Graduated Compound Rest. See pages 5 and 6.

The Practical Features such as Headstock Spindle, Graduated Compound Rest, Lead Screw, Micrometer Graduated Cross Feed Collar, and Set-Over Tailstock on the New Model 24-inch lathe are illustrated and described on pages 2 to 7.

The Attachments for South Bend Lathes are listed, illustrated and described in this catalog on pages 38 to 65. These attachments permit the lathe to be fitted up for various classes of special work which is so important in up-to-date machine shop practice.

The Regular Equipment included with each 24-inch Standard Change Gear Lathe consists of: Double Friction Countershaft, Set of Independent Change Gears, Large and Small Face Plates, Tool Post Complete, Thread Cutting Stop, Two Lathe Centers and Spindle Sleeve, Center Rest, Follower Rest and Wrenches. See page 33.

Lathe Features

- Independent change gears for threads and feeds.
- Back geared headstock gives eight spindle speeds.
- Spindle cone balanced for operating at high speeds.
- Automatic cross feed, automatic longitudinal feed.
- Hollow spindle, made of special carbon steel.
- Spring latch reverse for feeds and threads.
- Phosphor bronze spindle bearings.
- Graduated compound rest swivels to any angle.
- Tailstock is arranged for set-over for taper turning.
- Graduated collar on cross feed, compound rest screws.
- Precision lead screw for cutting accurate threads.

Lathe Specifications

- Head and Tail Spindle Centers . . . No. 4 Morse Taper
- Size of Spindle Nose 3 1/4 in. diam., 5 Threads
- Acme Lead Screw 4 Threads per inch
- Screw Thread Cutting Range 4 to 40 per inch
- Width of Cone Pulley Belt 3 1/2 in.
- Spindle Speeds . . 10, 16, 25, 40, 100, 150, 225, 355 R.P.M.
- Countershaft Speed 150 R.P.M.
- Maximum Draw-in Collet Chuck Capacity . . . 1 3/8 in.
- Countershaft Friction Clutch Pulleys . . . 14 in. x 5 in.
- Angular Travel of Compound Rest Top 5 3/4 in.
- Size of Lathe Tool Shank 3/4 in x 1 1/8 in.

Net Factory Prices 24-inch Standard Change Gear Lathe Including Overhead Countershaft and Equipment

No. of Lathe	Swing Over Bed	Length of Bed	Between Centers	Hole Thru Spindle	Swing Over Carriage	Power Required	Weight Crated	Code Word	Price F.O.B. South Bend
57-E	24 1/4 in.	8 ft.	43 in.	1 3/4 in.	17 3/8 in.	3 H.P.	4450 lbs.	Walet	\$1180.00
57-G	24 1/4 in.	10 ft.	67 in.	1 3/4 in.	17 3/8 in.	3 H.P.	4700 lbs.	Westa	1260.00
*57-H	24 1/4 in.	12 ft.	91 in.	1 3/4 in.	17 3/8 in.	3 H.P.	5100 lbs.	Wigen	1360.00
*57-K	24 1/4 in.	14 ft.	115 in.	1 3/4 in.	17 3/8 in.	3 H.P.	5370 lbs.	Wofed	1440.00
*57-M	24 1/4 in.	16 ft.	139 in.	1 3/4 in.	17 3/8 in.	3 H.P.	5650 lbs.	Wuchi	1520.00

*Lathes with 12-foot, 14-foot and 16-foot beds are equipped with center leg which is included in price of lathe.

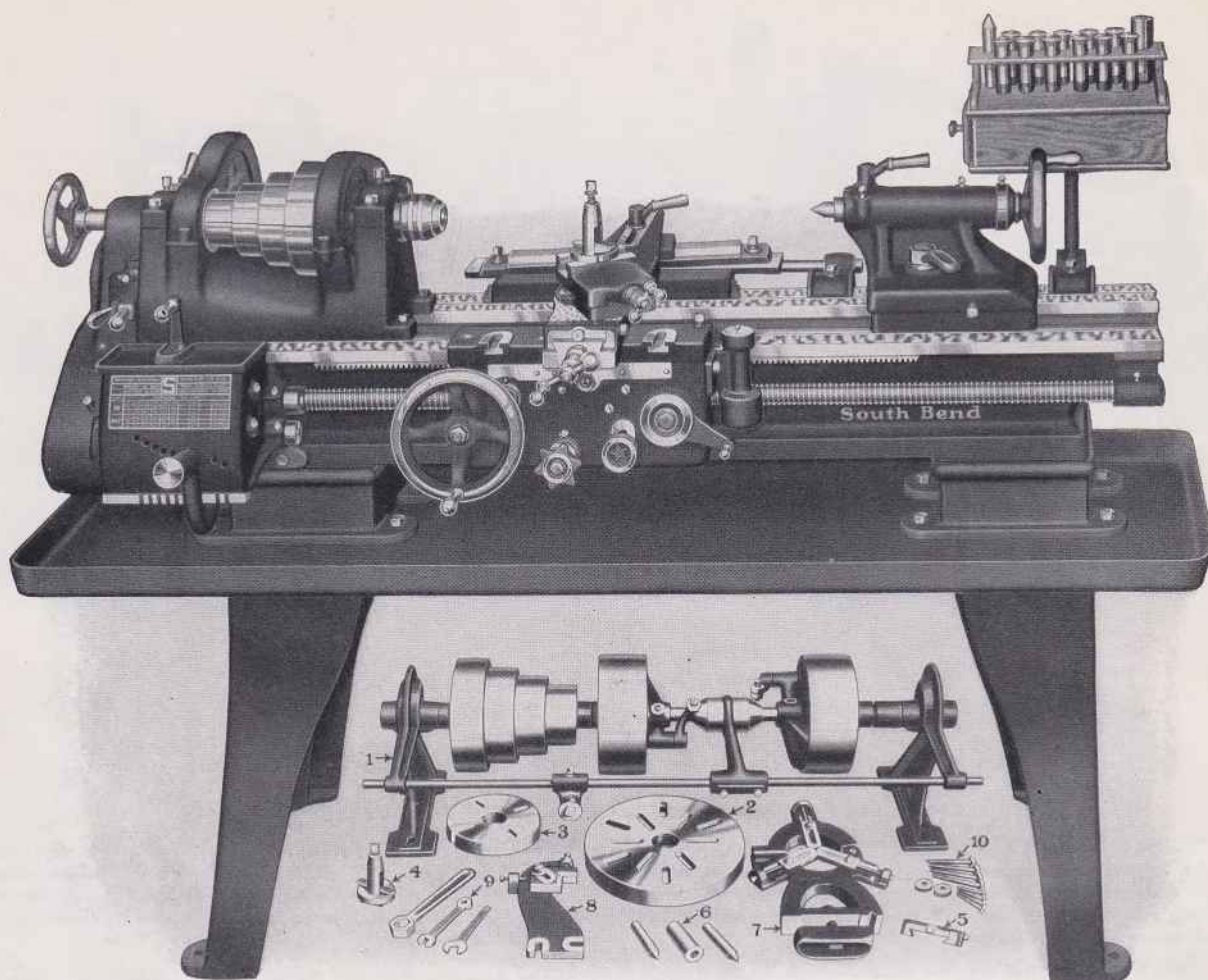

Equipment illustrated under Lathe is included in price of Lathe

No. 886—13" x 5' Tool Room Precision Lathe Overhead Countershaft Drive

The New Model South Bend Tool Room Precision Lathe sets a new standard of tool room performance; a marked advance in tool room efficiency, accuracy and precision.

The Illustration shows the 13-inch x 5-ft. Tool Room Quick Change Gear Lathe which we recommend for fine tool work. This lathe will meet the requirements of the expert mechanic.

South Bend Tool Room Lathes can be furnished in 11-inch, 13-inch and 16-inch sizes, with or without the special attachments. We list each attachment so that the customer can select only those required for his work. Attachments are described in this catalog.

Many Large Industrial Plants in this country are now using the 11-inch, 13-inch and 16-inch South Bend New Model Tool Room Lathes. We recommend them for the finest tool room work, such as, precision gauges, fixtures and accurate tools of all kinds.

The Regular Lathe Equipment included in the price of each South Bend Tool Room Lathe consists of: Double Friction Countershaft, Large and Small Face Plates, Tool Post complete, Thread Cutting Stop, two Lathe Centers and Spindle Sleeve, Center Rest, Follower Rest and Wrenches. For complete description of the regular equipment see page 33.

Net Factory Prices of Tool Room Quick Change Gear Precision Lathes with Overhead Countershaft Drive

Size of Lathe.....	No. 884-A—11" x 4'		No. 886-B—13" x 5'		No. 892-C—16" x 6'	
	Code Word	Price	Code Word	Price	Code Word	Price
Tool Room Quick Change Gear Lathe with Regular Equipment but without Special Attachments.....	Emdor	\$335.00	Gehos	\$402.00	Malta	\$540.00
SPECIAL ATTACHMENTS						
Hand Wheel Collet Chuck with One Collet.....(page 38)	Abode	38.00	About	44.00	Adore	56.00
Extra Collets $\frac{1}{8}$ -inch up to capacity by $\frac{1}{16}$ -inch Each..(page 39)	Cello	4.00	Chose	4.50	Clear	5.50
Taper Attachment.....(page 41)	Devor	60.00	Digit	70.00	Dress	85.00
Thread Dial.....(page 46)	Acres	8.00	Advis	10.00	Aflot	12.00
Oil Pan.....(page 45)	Odium	18.00	Obern	22.00	Okres	33.00
Micrometer Carriage Stop.....(page 46)	Ceded	10.00	Chain	10.00	Climb	10.00
Collet Cabinet and Bracket.....	Caged	12.00	Caged	12.00	Caged	12.00
Net Factory Prices of Tool Room Lathe Complete.....		\$485.00		\$574.50		\$753.50

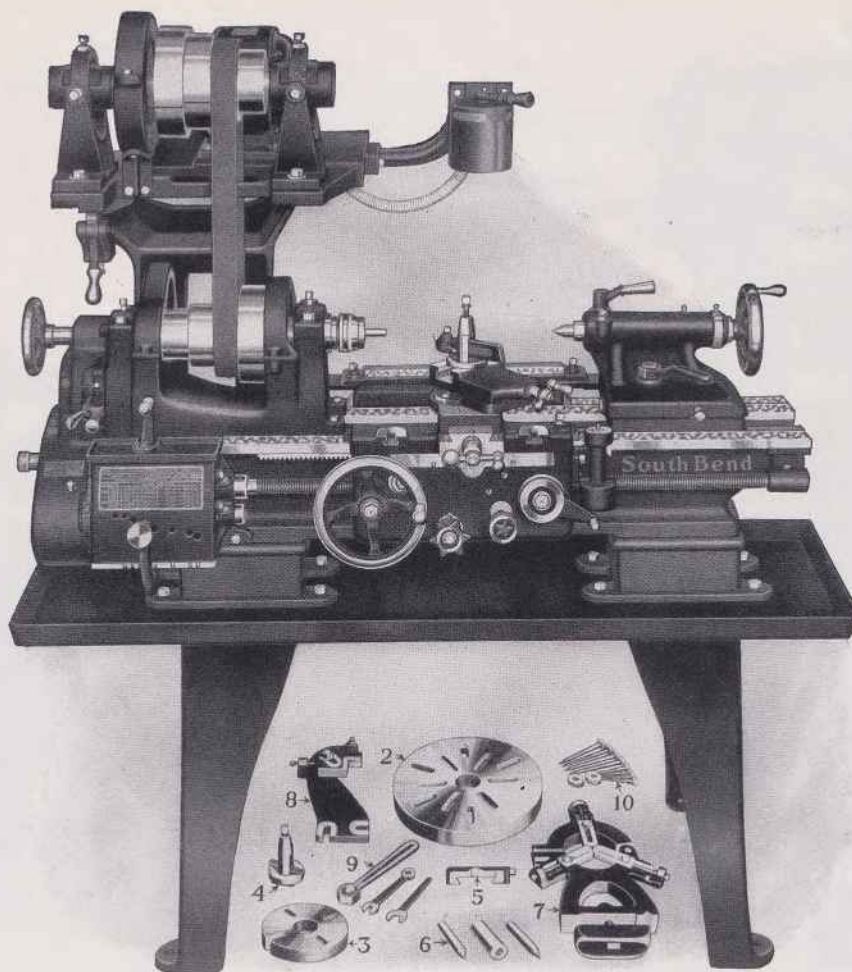

Equipment illustrated under Lathe is included in price of Lathe

No. 3886—13" x 4' Tool Room Precision Lathe Silent Chain Motor Drive Lathe

The New Model South Bend Silent Chain Motor Driven Tool Room Precision Lathe sets a new standard of tool room performance; a marked advance in tool room efficiency, accuracy and precision.

The Illustration shows the 13-inch x 4-ft. Silent Chain Motor Driven Tool Room Quick Change Gear Lathe which we recommend for fine tool work. This lathe will meet the requirements of the expert mechanic.

South Bend Silent Chain Motor Driven Tool Room Lathes can be furnished in the 11-inch, 13-inch and 16-inch sizes, with or without the special attachments. We list each attachment so that the customer can select only those required for his work. All of the attachments are illustrated and described in this catalog.

Electrical Equipment included in the price of the Silent Chain Motor Driven Tool Room Lathe consists of a three-phase, sixty-cycle, A.C., 1200 R.P.M. Reversing Motor (Westinghouse, General Electric or equal make), Reversing Switch (drum type), Wiring between Motor and Switch, Flexible Metal Conduit, Wiring Diagram and a Leather Belt.

Regular Lathe Equipment included in the price of the Silent Chain Motor Driven Tool Room Lathe consists of a Large Face Plate, Small Face Plate, Tool Post complete, Adjustable Thread Cutting Stop, two Lathe Centers and Spindle Sleeve, Center Rest, Follower Rest, Lag Screws and Washers, and Wrenches.

Net Factory Prices of Silent Chain Motor Driven Tool Room Quick Change Gear Lathe with 3-phase, 60-cycle, A.C. Reversing Motor and Reversing Switch

Size of Lathe.....	No. 3884-A—11" x 4'		No. 3886-A—13" x 4'		No. 3892-C—16" x 6'	
	Code Word	Price	Code Word	Price	Code Word	Price
Silent Chain Motor Driven Tool Room Quick Change Gear Lathe with Electrical Equipment but without Special Attachments.....	Eerow	\$455.00	Gazed	\$525.00	Madge	\$695.00
SPECIAL ATTACHMENTS						
Hand Wheel Collet Chuck with One Collet.....(page 38)	Abode	38.00	About	44.00	Adore	56.00
Extra Collets $\frac{1}{8}$ -inch up to capacity by $\frac{1}{16}$ -inch Each.(page 39)	Cello	4.00	Chose	4.50	Clear	5.50
Taper Attachment.....(page 41)	Devor	60.00	Digit	70.00	Dress	85.00
Thread Dial.....(page 46)	Aeres	8.00	Advis	10.00	Aflot	12.00
Oil Pan.....(page 45)	Odium	18.00	Odium	20.00	Okres	33.00
Micrometer Carriage Stop.....(page 46)	Ceded	10.00	Chain	10.00	Climb	10.00
Collet Cabinet and Bracket.....	Caged	12.00	Caged	12.00	Caged	12.00
Prices of Silent Chain Motor Driven Tool Room Lathe Complete.....		\$605.00		\$695.50		\$908.50

Prices of Silent Chain Motor Driven Tool Room Lathe equipped with D.C. Motor and single-phase, A.C. Motor, on request.

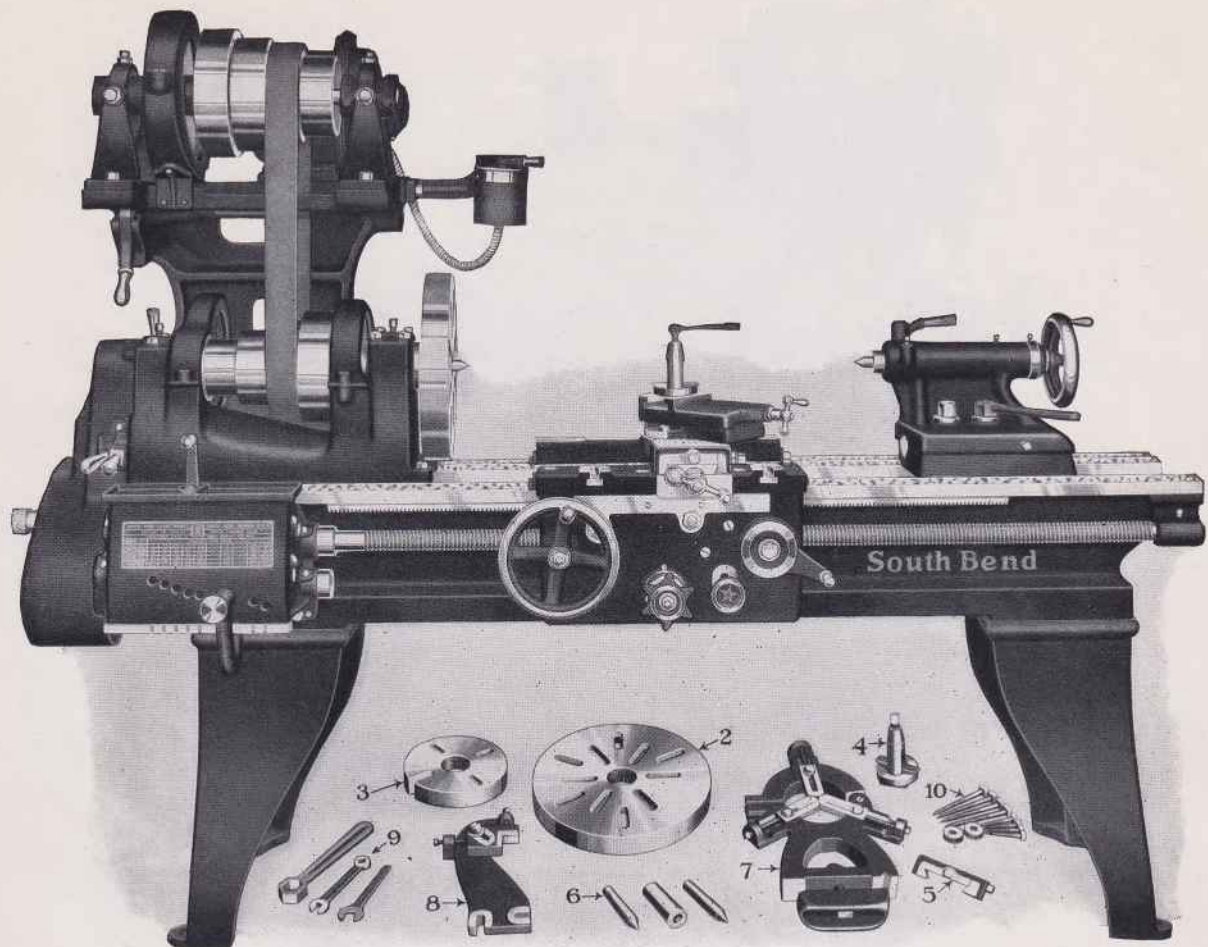

Lathe Equipment Included in Price of Silent Chain Motor Drive Lathe

The New Model Silent Chain Motor Driven Lathe

Eight Sizes—9-inch to 24-inch Swing—Standard and Quick Change Gear Lathes

Reversing Motor and Reversing Switch (Drum Type) are included in price of Lathe

Practical Motor Drive Lathe

The New Model Silent Chain Motor Drive Lathe is practical and efficient. This Silent Chain Motor Drive Unit is the ideal electric drive for the Screw Cutting Lathe. It is powerful and eliminates vibration and noise. The power is delivered from the motor through the Silent Chain and then by belt to the lathe spindle. This means that the cutting tool will always leave a smooth even surface made possible by the combination of a Silent Chain Drive from the motor and a belt drive on the lathe spindle.

A Very Efficient Form of Drive

The Silent Chain Motor Drive is an exclusive South Bend feature and is as positive as though it were direct geared. It eliminates noise and vibration caused by gears, and is more efficient than either a gear or belt drive.

Current Requirements

On page 29 we price Silent Chain Motor Driven Quick Change Gear and Standard Change Gear Lathes with Reversing Motors, Single and Three-phase, 110 or 220-volt, 60-cycle A.C.—and D.C. Motors, 115 or 230-volt.

Reversing Motor

The reversing motor is mounted above the lathe, on the hinged motor table, and is connected to the driving cone by a wide silent chain, which is as efficient as gearing yet eliminates all chattering, vibration and noise. The driving cone is connected to the spindle cone of the lathe by a leather belt which provides the driving power with the utmost smoothness.

Reversing Motors and Reversing Switches

We recommend that a Motor Drive Screw Cutting Lathe be operated with a reversing motor of 1200 R.P.M. and a reversing switch (drum type) for controlling the reversing motor. This is the most efficient type of motor drive for a screw cutting lathe because the reversing feature is used so much in cutting screw threads of all kinds.

Non-Reversing Motors

South Bend Motor Driven Lathes can be supplied with non-reversing 1800 R.P.M. motors and non-reversing switches at a much lower price, but this type of motor drive equipment is not efficient or practical on a screw cutting lathe for general machine work.

Description of Silent Chain Motor Drive Lathes continued on page 27.

Silent Chain Motor Drive for New Model South Bend Lathes

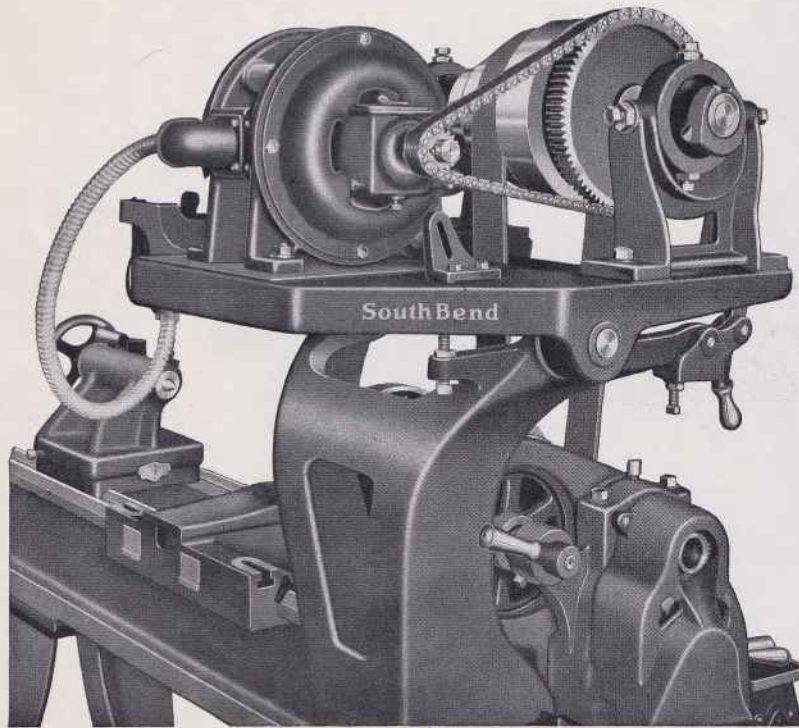

End View of Silent Chain Drive, Gear Guard Removed

The Silent Chain

The Silent Chain is the ideal drive for conveying power from the motor to the countershaft, because it eliminates vibration and noise. The spindle cone is driven by a leather belt which eliminates vibration, allowing the tool to take a smooth cut on the work in the lathe.

Reversing Control Switch (Drum Type)

Included in the Price of South Bend Motor Driven Lathes



The Drum Type Reversing Control Switch is the most practical switch for the efficient operation of a screw cutting lathe. It has a rotary motion which is so necessary on a motor driven screw cutting lathe because of the continual starting, stopping and reversing of the lathe spindle.

The Switch Lever has three positions. Left for forward motion of the Lathe spindle, center for neutral, and right for reverse motion of the spindle. The electrical connection between the motor and switch is enclosed in a flexible steel conduit.

Push Button Control

The Silent Chain Motor Drive Lathe can be furnished with Push Button Control instead of Drum Type Switch at extra cost. Prices of the various Motor Driven Lathes equipped with Push Button Control will be furnished on request. We recommend the Drum Type Reversing Switch.

Importance of Motor Position

The Motor is mounted above the lathe so as to prevent chips and dirt from falling into the armature or field coils to interfere with its efficient operation. The link belt silent chain which connects the motor with the upper cone is provided with a felt wick oiler and is entirely enclosed in an improved guard.

The Motor Table is supported by a heavy rigid bracket mounted directly on the Lathe Bed. This prevents any strain or motor vibration from being transmitted to the Headstock. A small lever allows the Table on which the Motor rests to tilt and relieve the belt tension for easy shifting. An independent adjustment is provided for taking up the stretch of the belt.

Constant Speed Motor Used

The Cone Pulleys and the Back Gears of the Headstock provide a wide range of spindle speeds which eliminates the expense of special variable or adjustable speed Motors, allowing standard, constant speed, alternating or direct current reversing motors to be used.

Fitting Motors to Lathe

Silent Chain Motor Driven Lathes come regularly equipped with a 1200 R.P.M. Reversing Motor and a Reversing Switch. The Motors used on South Bend Silent Chain Motor Driven Lathes are of General Electric and Westinghouse make, or equal. Occasionally a purchaser will request us to quote on Silent Chain Motor Driven Lathes without the Motor, Switch, or Wiring. We do not recommend this because it is best to operate and test the unit completely in our testing room before it leaves the factory.

Factory Test of Motor Drive Lathes

Each Motor Driven Lathe is set up, operated under its own power and thoroughly tested before shipping. We also test and inspect the wiring between the Motor and the Switch. This wiring is encased in a metal conduit to meet the requirements of the Underwriters' specifications. It is very important that these tests be made so that when the Lathe arrives it will be ready to run without the necessity of making numerous inspections and adjustments for overcoming faulty wiring connections and similar troubles.

Reversing Motor and Reversing Switch

Are Included in the Price of South Bend Motor Driven Lathes

South Bend Motor Driven Lathes are shipped complete with reversing motor and reversing switch ready for installation in the customer's shop. Both the reversing motor and the reversing switch are necessary to the practical operation of a screw cutting lathe and that is why we include them in the price of the Motor Driven Lathe so that when the customer receives the shipment, it will include everything that is necessary for the successful operation of the lathe.

Horsepower of Motor Required for Driving South Bend Lathes

Size of Lathe.....	9 in.	11 in.	13 in.	15 in.	16 in.	18 in.	21 in.	24 in.
Horsepower of Motor..	1/4	1/2	3/4	1	1	2	3	3
Speed of Motor, R.P.M.	1150 to 1200	1150 to 1200	1150 to 1200	1150 to 1200	1150 to 1200	1150 to 1200	1150 to 1200	1150 to 1200

Description of Silent Chain Motor Drive Lathes continued on page 28.

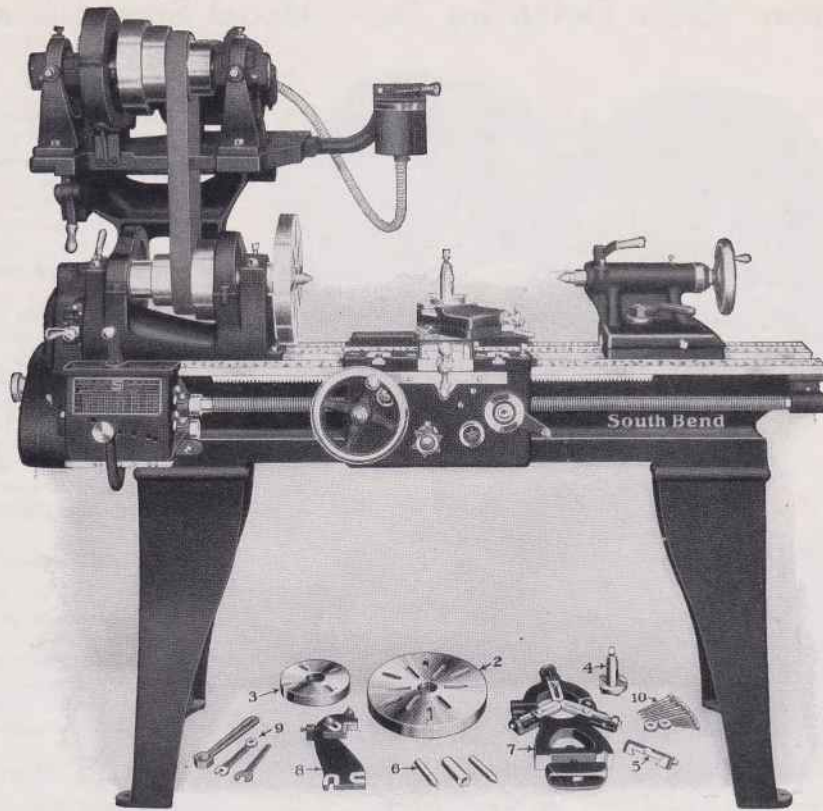

Equipment is Included in Price of Silent Chain Motor Drive Lathes

The New Model 13-inch Silent Chain Motor Driven Lathe

Description of Silent Chain Motor Drive Lathes Continued from Page 27

Lathe Equipment Included in Price

Equipment of Quick Change Gear Lathe

Lathe equipment included in the price of all size New Model Quick Change Gear Silent Chain Motor Driven Lathes consists of large and small face plate, tool post complete, thread cutting stop, two lathe centers and spindle sleeve, center rest, follower rest and wrenches. (This equipment is shown in the illustration of the 13-inch Silent Chain Motor Driven Lathe above.)

Equipment of Standard Change Gear Lathe

The New Model Standard Change Gear Silent Chain Motor Drive Lathe includes the regular equipment described above for the Quick Change Gear Lathe, and in addition a set of Independent Change Gears for thread cutting and for automatic feeds.

Electrical Equipment Included in Price

Electrical equipment included in the price of the Quick Change Gear and Standard Change Gear Silent Chain Motor Driven Lathes consists of a reversing motor, 1200 R.P.M., Westinghouse, General Electric, or equal make, reversing switch, wiring between motor and switch, flexible metal conduit, wiring diagram and a leather belt.

Description of Each Size Lathe

For more complete description of each size of South Bend Lathe, refer to corresponding size of Straight Bed Lathes pages 8 to 23. The only difference between the Silent Chain Motor Driven Lathe and the Overhead Countershaft Driven Lathe is the type of drive.

Specifications of Electric Current

When ordering a Silent Chain Motor Driven Lathe, specify the available current in your shop. This information can be secured from the electric light and power company, also from the electric meter in your shop.

If the current is alternating, specify exact voltage, phase, cycle and number of wires.

If direct current, state voltage only.

Various Types of Motors

We carry in stock the various sizes and types of single-phase, 60-cycle, A.C. motors; three-phase, 60-cycle, A.C. motors and D.C. motors in the various voltages. This stock of motors permits making immediate shipment of Motor Driven Lathes taking any of these motors. In supplying Motor Driven Lathes equipped with 25-cycle, 30-cycle, 40-cycle or 50-cycle A.C. motors there is only a short delay. The motor manufacturers, General Electric and Westinghouse, carry most of these motors in stock in Chicago.

Code Words for Motor Specifications

Use code words when ordering by telegram or cablegram the New Model South Bend Silent Chain Motor Driven Lathes. These code words will be found in the Silent Chain Motor Driven tabulation on page 29.

In the tabulation below we are showing code words to cover the popular motor specifications. These code words enable you to specify the kind of motor you wish.

Code Word	Current Specifications
Zapin	1-phase, 60-cycle, 110-volt A.C. Motor
Zbras	1-phase, 60-cycle, 220-volt A.C. Motor
Zingo	3-phase, 60-cycle, 110-volt A.C. Motor
Zompe	3-phase, 60-cycle, 220-volt A.C. Motor
Zurik	115-volt D.C. Motor
Zuwel	230-volt D.C. Motor

Example: When ordering No. 392-E, 16 x 8 Silent Chain Motor Driven Lathe equipped with 3-phase, 60-cycle, 220-volt A.C. motor, specify the code word "Mears Zompe." The code word "Mears" covers the Lathe and the code word "Zompe" covers the motor specifications. Any South Bend Motor Driven Lathe can be ordered by code by following the same procedure.

If your motor specifications differ from those that we list above, give us the exact voltage, phase and cycle when placing your order by telegram or cablegram.

Net Factory Prices of Silent Chain Motor Drive Lathes

Prices listed in tabulation below are net F.O.B. South Bend, crated for domestic shipment and include the Regular Lathe Equipment (illustrated under lathe on pages 26 and 28), a 1200 R.P.M. Reversing Motor, Reversing Switch, Wiring between Motor and Switch, and Leather Belt.

Code Words. When ordering Motor Driven Lathes by telegram or cablegram use code words in tabulation below to indicate the size. Use code words shown on page 28 to indicate motor specifications.

Motor Specifications. When ordering a Silent Chain Motor Driven Lathe give the following information regarding the electric current to be used so that the proper style and type of Reversing Motor can be furnished:

—If Alternating, state exact voltage, phase, cycle, and number of wires

—If Direct, state exact voltage only

Swing Over Bed	Length of Bed	Size of Motor	Approx Weight Crated	Quick Change Gear Lathes					Standard Change Gear Lathes				
				Catalog Number of Lathe	Code Word	With 3 Phase 60 Cycle A.C. Motor	With Single Phase 60 Cycle A.C. Motor	With Direct Current Motor	Catalog Number of Lathe	Code Word	With 3 Phase 60 Cycle A.C. Motor	With Single Phase 60 Cycle A.C. Motor	With Direct Current Motor
9-inch South Bend Motor Driven Lathes													
9 1/4 in.	2 1/2 ft.	1/4 H.P.	670 lbs.	382-X	Baten	\$ 366.00	\$ 381.00	\$ 369.00	331-X	Bread	\$ 331.00	\$ 346.00	\$ 334.00
9 1/4 in.	3 ft.	1/4 H.P.	690 lbs.	382-Y	Betal	371.00	386.00	374.00	331-Y	Bucar	336.00	351.00	339.00
9 1/4 in.	3 1/2 ft.	1/4 H.P.	710 lbs.	382-Z	Binks	376.00	391.00	379.00	331-Z	Bvint	341.00	356.00	344.00
9 1/4 in.	4 ft.	1/4 H.P.	730 lbs.	382-A	Blast	381.00	396.00	384.00	331-A	Bwity	346.00	361.00	349.00
9 1/4 in.	4 1/2 ft.	1/4 H.P.	750 lbs.	382-R	Board	386.00	401.00	389.00	331-R	Bzump	351.00	366.00	354.00
11-inch South Bend Motor Driven Lathes													
11 1/4 in.	3 ft.	1/2 H.P.	870 lbs.	384-Y	Eadow	445.00	471.00	454.00	333-Y	Eflam	410.00	436.00	419.00
11 1/4 in.	3 1/2 ft.	1/2 H.P.	895 lbs.	384-Z	Ebert	450.00	476.00	459.00	333-Z	Eguil	415.00	441.00	424.00
11 1/4 in.	4 ft.	1/2 H.P.	920 lbs.	384-A	Eerow	455.00	481.00	464.00	333-A	Ehams	420.00	446.00	429.00
11 1/4 in.	5 ft.	1/2 H.P.	1035 lbs.	384-B	Edaze	465.00	491.00	474.00	333-B	Eioaw	430.00	456.00	439.00
13-inch South Bend Motor Driven Lathes													
13 1/4 in.	4 ft.	3/4 H.P.	1460 lbs.	386-A	Gazed	525.00	590.00	534.00	335-A	Glubr	475.00	540.00	484.00
13 1/4 in.	5 ft.	3/4 H.P.	1510 lbs.	386-B	Gemic	537.00	602.00	546.00	335-B	Guest	487.00	552.00	496.00
13 1/4 in.	6 ft.	3/4 H.P.	1560 lbs.	386-C	Giraf	549.00	614.00	558.00	335-C	Gramp	499.00	564.00	508.00
13 1/4 in.	7 ft.	3/4 H.P.	1610 lbs.	386-D	Gotam	561.00	626.00	570.00	335-D	Grief	511.00	576.00	520.00
13 1/4 in.	8 ft.	3/4 H.P.	1685 lbs.	386-E	Gneza	573.00	638.00	582.00	335-E	Gwilt	523.00	588.00	532.00
15-inch South Bend Motor Driven Lathes													
15 1/4 in.	5 ft.	1 H.P.	1925 lbs.	388-B	Labor	628.00	701.00	707.00	339-B	Loane	568.00	641.00	647.00
15 1/4 in.	6 ft.	1 H.P.	2025 lbs.	388-C	Leone	643.00	716.00	722.00	339-C	Longe	583.00	656.00	662.00
15 1/4 in.	7 ft.	1 H.P.	2075 lbs.	388-D	Leper	658.00	731.00	737.00	339-D	Lotus	598.00	671.00	677.00
15 1/4 in.	8 ft.	1 H.P.	2150 lbs.	388-E	Licen	673.00	746.00	752.00	339-E	Luela	613.00	686.00	692.00
15 1/4 in.	10 ft.	1 H.P.	2300 lbs.	388-G	Lindy	703.00	776.00	782.00	339-G	Lyric	643.00	716.00	722.00
16-inch South Bend Motor Driven Lathes													
16 1/4 in.	6 ft.	1 H.P.	2310 lbs.	392-C	Madge	695.00	768.00	774.00	341-C	Mirac	635.00	708.00	714.00
16 1/4 in.	7 ft.	1 H.P.	2390 lbs.	392-D	Magpi	710.00	783.00	789.00	341-D	Moats	650.00	723.00	729.00
16 1/4 in.	8 ft.	1 H.P.	2470 lbs.	392-E	Mears	725.00	798.00	804.00	341-E	Moral	665.00	738.00	744.00
16 1/4 in.	10 ft.	1 H.P.	2630 lbs.	392-G	Metro	755.00	828.00	834.00	341-G	Music	695.00	768.00	774.00
16 1/4 in.	12 ft.	1 H.P.	2890 lbs.	392-H	Mires	800.00	873.00	879.00	341-H	Mybeu	740.00	813.00	819.00
18-inch South Bend Motor Driven Lathes													
18 1/4 in.	6 ft.	2 H.P.	3040 lbs.	394-C	Sacks	858.00	972.00	970.00	343-C	Sober	793.00	907.00	905.00
18 1/4 in.	7 ft.	2 H.P.	3140 lbs.	394-D	Sarge	883.00	997.00	995.00	343-D	Sorel	818.00	932.00	930.00
18 1/4 in.	8 ft.	2 H.P.	3240 lbs.	394-E	Semin	908.00	1022.00	1020.00	343-E	South	843.00	957.00	955.00
18 1/4 in.	10 ft.	2 H.P.	3440 lbs.	394-G	Seoul	958.00	1072.00	1070.00	343-G	Sucre	893.00	1007.00	1005.00
18 1/4 in.	12 ft.	2 H.P.	3740 lbs.	394-H	Simpe	1023.00	1137.00	1135.00	343-H	Sugar	958.00	1072.00	1070.00
18 1/4 in.	14 ft.	2 H.P.	4140 lbs.	394-K	Sinks	1083.00	1197.00	1195.00	343-K	Synth	1018.00	1132.00	1130.00
21-inch South Bend Motor Driven Lathes													
21 1/4 in.	7 ft.	3 H.P.	4240 lbs.	396-D	Taels	1254.00	1388.00	1413.00	349-D	Tiber	1174.00	1308.00	1333.00
21 1/4 in.	8 ft.	3 H.P.	4440 lbs.	396-E	Tanke	1284.00	1418.00	1443.00	349-E	Tiles	1204.00	1338.00	1363.00
21 1/4 in.	10 ft.	3 H.P.	4690 lbs.	396-G	Tawse	1344.00	1478.00	1503.00	349-G	Torch	1264.00	1398.00	1423.00
21 1/4 in.	12 ft.	3 H.P.	5050 lbs.	396-H	Telma	1419.00	1553.00	1578.00	349-H	Tough	1339.00	1473.00	1498.00
21 1/4 in.	14 ft.	3 H.P.	5270 lbs.	396-K	Tense	1479.00	1613.00	1638.00	349-K	Tucan	1399.00	1533.00	1558.00
24-inch South Bend Motor Driven Lathes													
24 1/4 in.	8 ft.	3 H.P.	5365 lbs.	398-E	Wails	1634.00	1767.00	1793.00	357-E	Winth	1534.00	1667.00	1693.00
24 1/4 in.	10 ft.	3 H.P.	5615 lbs.	398-G	Wajoh	1714.00	1847.00	1873.00	357-G	Wopal	1614.00	1747.00	1773.00
24 1/4 in.	12 ft.	3 H.P.	6015 lbs.	398-H	Weirs	1814.00	1947.00	1973.00	357-H	Words	1714.00	1847.00	1873.00
24 1/4 in.	14 ft.	3 H.P.	6285 lbs.	398-K	Werow	1894.00	2027.00	2053.00	357-K	Wudin	1794.00	1927.00	1953.00
24 1/4 in.	16 ft.	3 H.P.	6565 lbs.	398-M	Wilow	1974.00	2107.00	2133.00	357-M	Wugor	1874.00	2007.00	2033.00

Prices of Silent Chain Motor Driven Lathes equipped with 50-cycle motor are the same as prices of Lathes with 60-cycle motor. Prices of Silent Chain Motor Driven Lathes equipped with 25-cycle motor will be quoted on request.

Extra for Silent Chain Motor Driven Lathes with Double Gap Bed

How to Figure Prices

The New South Bend Silent Chain Motor Driven Lathes can be supplied at extra cost with Double Gap Bed.

To figure the prices of Double Gap Bed Silent Chain Motor Driven Lathes, add the price listed in the panel to the right, to the price of the corresponding size of Straight Bed Silent Chain Motor Driven Lathe appearing above.

Catalog Numbers		Size of Lathe	Swing Over Straight Bed	Swing Over Gap	Total Width of Gap	Width of Each Bridge	Prices Extra for Gap Bed and Bridge
Standard Change	Quick Change						
3633	3684	11 in.	11 1/4 in.	16 in.	5 in.	2 1/2 in.	\$ 50.00
3635	3686	13 in.	13 1/4 in.	19 in.	7 in.	3 1/2 in.	60.00
3639	3688	15 in.	15 1/4 in.	22 in.	8 in.	4 in.	70.00
3641	3692	16 in.	16 1/4 in.	24 in.	8 1/2 in.	4 1/2 in.	80.00
3643	3694	18 in.	18 1/4 in.	26 in.	10 in.	5 in.	90.00
3649	3698	21 in.	21 1/4 in.	30 in.	12 in.	6 in.	125.00
3657	3698	24 in.	24 1/4 in.	36 in.	15 in.	7 1/2 in.	175.00

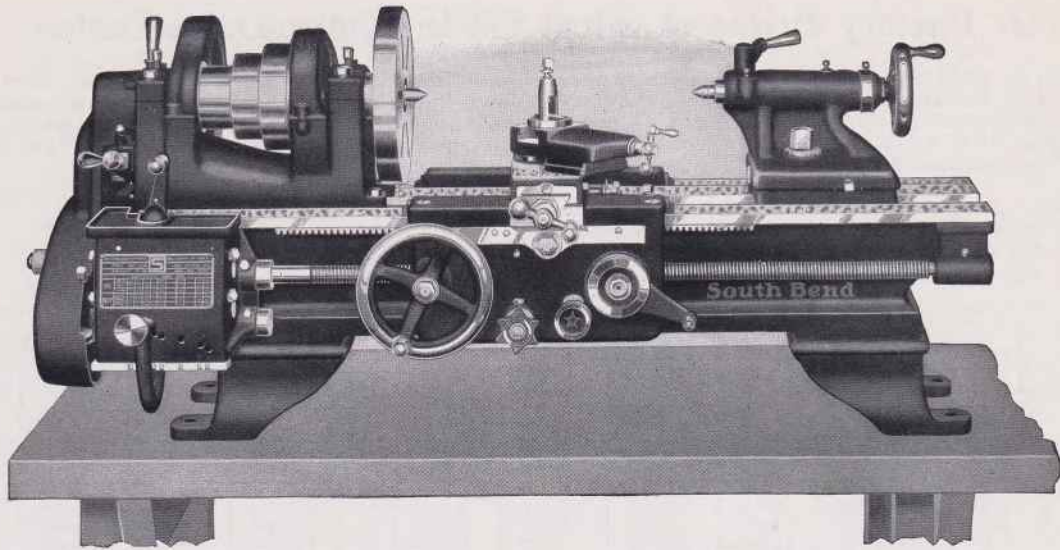

The New Model South Bend Bench Lathes

Built in 9-inch, 11-inch and 13-inch Swing—Standard and Quick Change Gear Lathes

The illustration above shows the New Model 11-inch Quick Change Gear Bench Lathe operated by overhead countershaft drive.

For Specifications and description of the 9-inch, 11-inch and 13-inch Bench Lathes Quick Change Gear or Standard Change Gear, refer to the 9-inch, 11-inch, or 13-inch Lathes with floor legs illustrated in the front part of catalog. The only difference is that the Bench Legs are substituted for Floor Legs.

Bench Lathes are used to advantage in factories for large production of small metal parts and for fine tool work. These lathes are sometimes arranged in groups.

Types of Drives. Bench Lathes may be driven by three types of drives: Overhead Countershaft Drive (shown above), Simplex Motor Drive (page 31), Self-contained Unit Motor Drive (page 32).

Attachments. Bench Lathes may be fitted with all the Attachments, Tools and Accessories that can be used on Floor Leg Lathes such as Draw-in Collet Chuck, Taper Attachment, Milling and Keyway Cutting Attachment, Chucks, Turning and Boring Tools, etc.

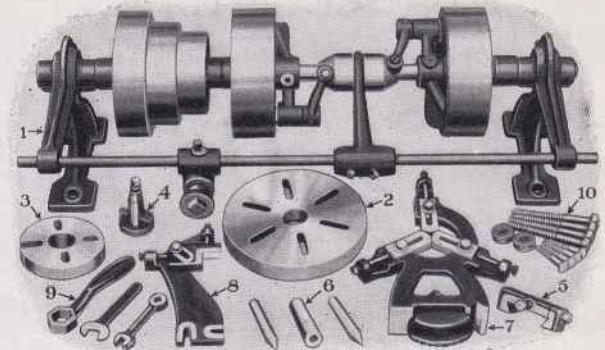

Countershaft and Equipment Illustrated Above Is Included in the Price of the Lathe

Equipment. The double friction countershaft and equipment illustrated above is included in the price of Bench Lathes. For complete description of equipment see page 33.

The Hard Maple Bench is not included in the price of the Bench Lathes but can be furnished at extra cost. For prices and descriptions of Bench see page 57.

Net Factory Prices of Bench Lathes with Compound Rest, Overhead Countershaft and Equipment

Swing Over Bed	Length of Bed	Between Centers	Hole Thru Spindle	Power Required	Weight Crated	Quick Change Gear			Standard Change Gear		
						Cat. No.	Code Word	Price	Cat. No.	Code Word	Price
9-inch New Model South Bend Bench Lathes											
9¼ in.	2½ ft.	11 in.	¾ in.	¼ H.P.	405 lbs.	82-XB	Backe	\$255.00	31-XB	Bride	\$220.00
9¼ in.	3 ft.	18 in.	¾ in.	¼ H.P.	425 lbs.	82-YB	Belts	260.00	31-YB	Bulks	225.00
9¼ in.	3½ ft.	23 in.	¾ in.	¼ H.P.	445 lbs.	82-ZB	Bingo	265.00	31-ZB	Bvork	230.00
9¼ in.	4 ft.	29 in.	¾ in.	¼ H.P.	465 lbs.	82-AB	Blame	270.00	31-AB	Bweir	235.00
9¼ in.	4½ ft.	36 in.	¾ in.	¼ H.P.	490 lbs.	82-RB	Bodel	275.00	31-RB	Bzone	240.00
11-inch New Model South Bend Bench Lathes											
11¼ in.	3 ft.	12 in.	¾ in.	½ H.P.	575 lbs.	84-YB	Ebony	\$315.00	33-YB	Egast	\$280.00
11¼ in.	3½ ft.	18 in.	¾ in.	½ H.P.	600 lbs.	84-ZB	Echos	320.00	33-ZB	Ejorn	285.00
11¼ in.	4 ft.	24 in.	¾ in.	½ H.P.	625 lbs.	84-AB	Edwin	325.00	33-AB	Elong	290.00
11¼ in.	5 ft.	36 in.	¾ in.	½ H.P.	705 lbs.	84-BB	Efort	335.00	33-BB	Emate	300.00
13-inch New Model South Bend Bench Lathes											
13¼ in.	4 ft.	16 in.	1 in.	¾ H.P.	956 lbs.	86-AB	Gales	\$380.00	35-AB	Gnome	\$330.00
13¼ in.	5 ft.	28 in.	1 in.	¾ H.P.	1006 lbs.	86-BB	Geral	392.00	35-BB	Gorst	342.00
13¼ in.	6 ft.	40 in.	1 in.	¾ H.P.	1056 lbs.	86-CB	Gildo	404.00	35-CB	Gropy	354.00

Motor rests on top of bench behind the lathe.

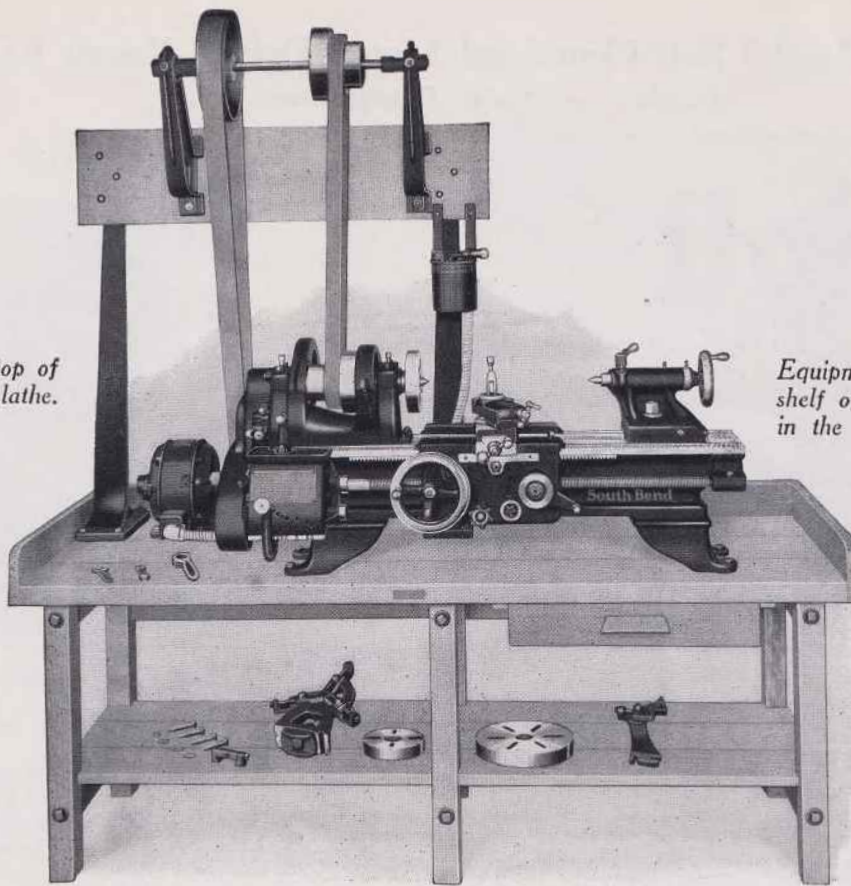

Equipment illustrated on shelf of bench is included in the price of the lathe.

The New Model Simplex Motor Driven Bench Lathe Unit

Built in 9-inch, 11-inch and 13-inch Swing—Standard and Quick Change Gear Lathes

The Simplex Drive Electrical Equipment Included in Price

The Simplex Motor Drive is a very practical method for driving a precision Bench Lathe used for general machine shop work and precision tool work. For specifications and descriptions of the 9-inch, 11-inch or 13-inch Bench Lathes refer to Lathes with floor legs illustrated in the front part of catalog.

The Reversing Switch (Drum Type)

The Reversing Switch (Drum Type) is conveniently located so that the operator can start, stop or reverse the lathe spindle from an easy working position in front of the lathe.

The 9-inch Simplex Bench Lathe Unit

A 1/4-horsepower Reversing Motor driven from an ordinary lamp socket gives sufficient power to operate the 9-inch Simplex Motor Driven Bench Lathe at maximum capacity.

Electrical equipment included in the price of the Simplex Motor Driven Lathe consists of a 1200 R.P.M., reversing motor, (Westinghouse, General Electric or equal make) reversing switch (drum type), wiring between motor and switch, flexible metal conduit, wiring diagram and two leather belts.

Lathe Equipment Included in Price

Lathe equipment included in the price of the Simplex Motor Driven Lathe consists of: Bench lathe with graduated compound rest, Simplex drive countershaft, large and small face plates, tool post complete, adjustable thread cutting stop, two lathe centers and spindle sleeve, center rest, follower rest, lag screws and washers, and wrenches, and independent change gears with Standard Change Gear Lathes.

Net Factory Prices Simplex Motor Driven Bench Lathe Units—Without Bench*

Prices of Lathe with Compound Rest, Reversing Motor, Reversing Switch

Swing Over Bed	Length of Bed	Size of Motor	Weight Crated Without Bench	Quick Change Gear					Standard Change Gear				
				Catalog No. of Lathe	Code Word	With 3 Phase 60 Cycle A.C. Motor	With Single Phase 60 Cycle A.C. Motor	With Direct Current Motor	Catalog No. of Lathe	Code Word	With 3 Phase 60 Cycle A.C. Motor	With Single Phase 60 Cycle A.C. Motor	With Direct Current Motor
9-inch Simplex Motor Driven Bench Lathe Unit													
9 3/4 in.	2 1/2 ft.	1/4 H.P.	505 lbs.	582-XB	Bader	\$318.00	\$332.00	\$320.00	531-XB	Brute	\$283.00	\$297.00	\$285.00
9 3/4 in.	3 ft.	1/4 H.P.	525 lbs.	582-YB	Beard	323.00	337.00	325.00	531-YB	Buted	288.00	302.00	290.00
9 3/4 in.	3 1/2 ft.	1/2 H.P.	545 lbs.	582-ZB	Bilet	328.00	342.00	330.00	531-ZB	Bvang	293.00	307.00	295.00
9 3/4 in.	4 ft.	1/2 H.P.	565 lbs.	582-AB	Block	333.00	347.00	335.00	531-AB	Bwast	298.00	312.00	300.00
9 3/4 in.	4 1/2 ft.	1/2 H.P.	590 lbs.	582-RB	Bobin	338.00	352.00	340.00	531-RB	Bzard	303.00	317.00	305.00
11-inch Simplex Motor Driven Bench Lathe Unit													
11 1/4 in.	3 ft.	1/2 H.P.	675 lbs.	584-YB	Eband	390.00	416.00	400.00	533-YB	Egren	355.00	381.00	365.00
11 1/4 in.	3 1/2 ft.	1/2 H.P.	700 lbs.	584-ZB	Ecors	395.00	421.00	405.00	533-ZB	Ejunk	360.00	386.00	370.00
11 1/4 in.	4 ft.	1/2 H.P.	725 lbs.	584-AB	Edsel	400.00	426.00	410.00	533-AB	Elake	365.00	391.00	375.00
11 1/4 in.	5 ft.	1/2 H.P.	805 lbs.	584-BB	Efair	410.00	436.00	420.00	533-BB	Emiro	375.00	401.00	385.00
13-inch Simplex Motor Driven Bench Lathe Unit													
13 1/4 in.	4 ft.	3/4 H.P.	1060 lbs.	586-AB	Gandy	464.00	528.00	473.00	535-AB	Gnavy	414.00	478.00	423.00
13 1/4 in.	5 ft.	3/4 H.P.	1110 lbs.	586-BB	Gentl	476.00	540.00	485.00	535-BB	Goler	426.00	490.00	435.00

*Hard Maple Bench is shown on page 57.

The New Model Self Contained Motor Driven Bench Lathe Unit

Standard and Quick Change Gear Lathes

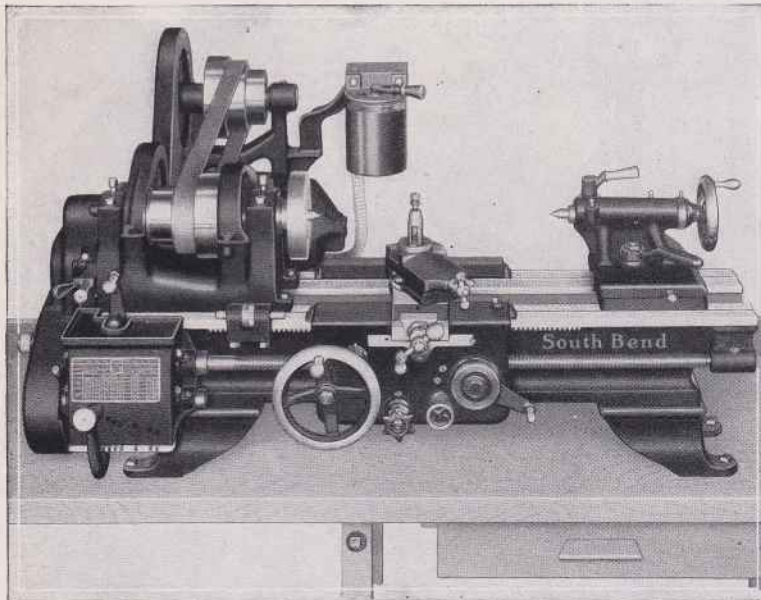

Front View of Self Contained Unit

The Self Contained Unit Drive is a practical drive for the 9-inch, 11-inch and 13-inch Bench Quick Change Gear and Standard Change Gear Lathes. When this unit is mounted on the Bench and connected to the current it is ready for operation.

Electrical Equipment Included in Price

Electrical equipment included in the price of the Self Contained Motor Drive Bench Lathe Unit consists of a 1/4-horsepower Reversing Motor 1200 R.P.M. Westinghouse, General Electric or equal make, Reversing Switch, Wiring between Motor and Switch, Flexible Metal Conduit and a Leather Belt.

Lathe Equipment Included in Price

Lathe equipment included in the price of the Self Contained Motor Drive Bench Lathe Unit consists of Bench Lathe with Graduated Compound Rest, Unit Motor Drive, Large and Small Face Plates, Tool Post Complete, Thread Cutting Stop, Two Lathe Centers and Spindle Sleeve, Center Rest, Follower Rest and Wrenches. A set of Independent Change Gears for thread cutting and automatic feed is also included with Standard Change Gear Lathes. See page 33. (Prices do not include Maple Bench, information of which will be found on page 57.)

Motor Specifications

When ordering a Self Contained Motor Driven Bench Lathe Unit be sure to specify the electric current. If alternating current, state exact voltage, phase, cycle and number of wires. If direct current state exact voltage.

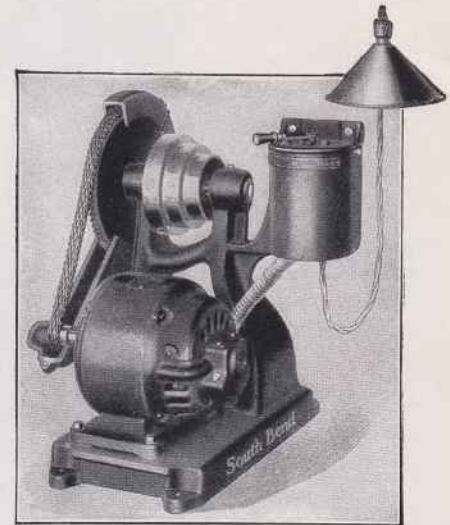

End View of the Drive Unit

Part of Gear Guard Removed to Show the Chain

The above illustration shows an end view of the Self Contained Unit Motor Drive. This unit is placed directly behind the lathe on the bench in such position that the cone pulleys will line up and the belts will track between the two cones.

The Motor rests on a base and drives the countershaft cone through a chain and sprocket which gives a noiseless, efficient drive for a screw cutting lathe.

The Reversing Switch (drum type) is conveniently located so that the operator can start, stop or reverse the motor from an easy working position in front of the lathe. The switch has three positions: Left, for forward motion of lathe spindle, center for neutral, and right for reverse.

The 9-inch Self Contained Motor Driven Bench Lathe Unit is equipped with 1/4-horsepower Reversing Motor that can be operated from an ordinary lamp socket, which gives sufficient power to operate the lathe at maximum capacity.

Net Factory Prices Self Contained Motor Driven Bench Lathe Unit—Without Bench*

Prices of Lathe with Compound Rest, Reversing Motor and Reversing Switch

Swing Over Bed	Length of Bed	Size of Motor	Weight Crated Without Bench	Quick Change Gear					Standard Change Gear				
				Catalog No. of Lathe	Code Word	With 3 Phase 60 Cycle A.C. Motor	With Single Phase 60 Cycle A.C. Motor	With Direct Current Motor	Catalog No. of Lathe	Code Word	With 3 Phase 60 Cycle A.C. Motor	With Single Phase 60 Cycle A.C. Motor	With Direct Current Motor
9-inch Self Contained Motor Driven Bench Lathe Unit													
9 1/4 in.	2 1/2 ft.	1/4 H.P.	490 lbs.	782-X	Baern	\$332.00	\$347.00	\$335.00	731-X	Braid	\$297.00	\$312.00	\$300.00
9 1/4 in.	3 ft.	3/8 H.P.	520 lbs.	782-Y	Bentr	337.00	352.00	340.00	731-Y	Bunko	302.00	317.00	305.00
9 1/4 in.	3 1/2 ft.	1/2 H.P.	550 lbs.	782-Z	Bidos	342.00	357.00	345.00	731-Z	Bvail	307.00	322.00	310.00
9 1/4 in.	4 ft.	5/8 H.P.	580 lbs.	782-A	Blota	347.00	362.00	350.00	731-A	Bwops	312.00	327.00	315.00
9 1/4 in.	4 1/2 ft.	3/4 H.P.	610 lbs.	782-R	Bosni	352.00	367.00	355.00	731-R	Bzpr	317.00	332.00	320.00
11-inch Self Contained Motor Driven Bench Lathe Unit													
11 1/4 in.	3 ft.	1/2 H.P.	640 lbs.	784-Y	Eastn	407.00	433.00	417.00	733-Y	Efade	372.00	398.00	382.00
11 1/4 in.	3 1/2 ft.	3/4 H.P.	670 lbs.	784-Z	Ebros	412.00	438.00	422.00	733-Z	Egrip	377.00	403.00	387.00
11 1/4 in.	4 ft.	5/8 H.P.	700 lbs.	784-A	Eclip	417.00	443.00	427.00	733-A	Ehows	382.00	408.00	392.00
11 1/4 in.	5 ft.	3/2 H.P.	730 lbs.	784-B	Ednor	427.00	453.00	437.00	733-B	Ejano	392.00	418.00	402.00
13-inch Self Contained Motor Driven Bench Lathe Unit													
13 1/4 in.	4 ft.	3/4 H.P.	1040 lbs.	786-A	Gafro	478.00	537.00	486.00	735-A	Gnult	432.00	491.00	440.00
13 1/4 in.	5 ft.	5/8 H.P.	1070 lbs.	786-B	Gepad	490.00	549.00	498.00	735-B	Gopca	444.00	503.00	452.00
13 1/4 in.	6 ft.	3/2 H.P.	1100 lbs.	786-C	Gical	502.00	561.00	510.00	735-C	Groat	456.00	515.00	464.00

*Hard Maple Bench is shown on page 57.

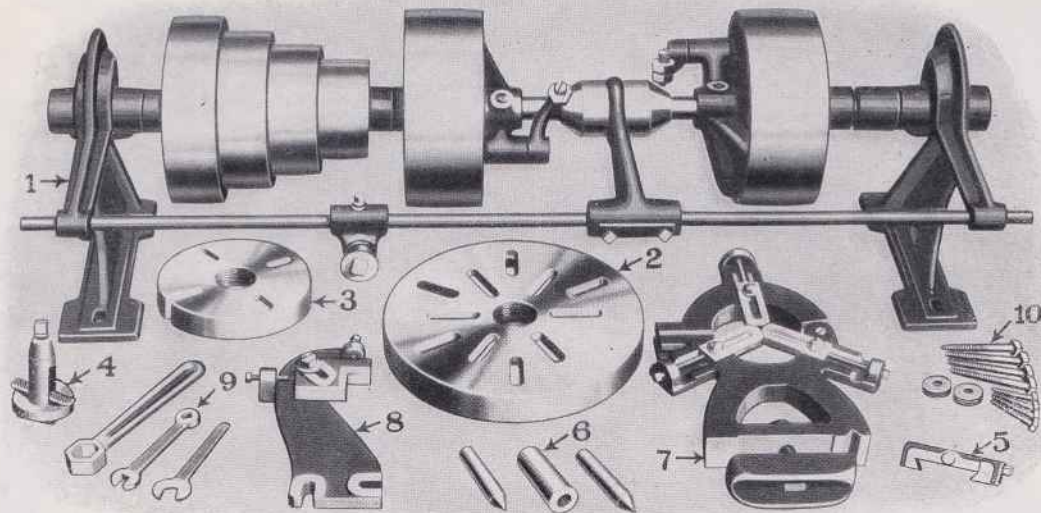

Countershaft and Regular Equipment of the Quick Change Gear Lathes

The illustration shown above shows the countershaft and equipment that is included in the price of the New Model South Bend Quick Change Gear Lathes. All these parts are necessary for the successful operation of the screw cutting lathe. Each part is numbered in the illustration and described in the paragraphs that follow.

1. **The Improved Double Friction Countershaft** provides a forward and reversing speed for the lathe spindle. Refer to complete description appearing below.
2. **The Large Face Plate** is threaded and fitted to the spindle nose of the lathe.
3. **The Small Face Plate** is threaded and fitted to the spindle nose of the lathe.
4. **Tool Post, Ring, Wedge and Wrench** are drop forged steel, case-hardened. The tool post set-screw is tool steel tempered.

5. **Adjustable Thread Cutting Stop** is used for regulating depth of chip in thread cutting.
6. **Two Tool Steel Lathe Centers**; the soft center and Taper sleeve are for the Headstock Spindle—the hardened center, marked with a groove, is for the Tailstock Spindle.
7. **Center Rest** supports long, slender work while being turned. It is also used when drilling, boring, reaming, threading, etc.
8. **Follower Rest** travels with the cutting tool, and supports long, slender work, while being machined.
9. **Wrenches** for adjusting Tailstock, setting Compound Rest and tightening Tool Post.
10. **Lag Screws**, for hanging countershaft and setting lathe to floor.

Countershaft and Regular Equipment for Standard Change Gear Lathes

The Standard Change Gear Lathes take the same type of countershaft and regular equipment illustrated above for Quick Change Gear Lathes and in addition a set of Independent Change Gears for thread cutting and turning feeds. These change gears are illustrated below.



Independent Change Gears

Gears for Thread Cutting and Turning Feeds

The Independent Change Gears that are included with the regular equipment for the Standard Change Gear Lathes provide for cutting right and left hand screw threads as shown on the index plate attached to each lathe. Compound Gears and Gears to take care of the various Automatic Cross and Longitudinal Feeds are also included in the equipment.

Index Plate for Screw Threads

A metal Index Plate is attached to each South Bend Standard Change Gear Lathe which enables the operator to select the proper gears for cutting different pitches of Screw Threads. On Standard Change Gear Lathes all standard screw threads from 4 to 40 per inch, right or left, including 11½ pipe thread, can be cut.

Threads other than the ones enumerated can be cut by compounding the gears furnished with the lathe. A swinging gear guard on the lathe permits easy access to these gears.

SOUTH BEND TRADE MARK ENGINE LATHES		
13-15-16		
THREAD	SPINDLE	SCREW
4	48	32
5	48	40
6	48	48
7	48	56
8	48	64
9	48	72
10	48	80
11	24	44
11½	24	48
12	24	48
13	24	52
14	24	56
16	24	64
18	24	72
20	24	80
22	24-1-2	44
24	24-1-2	48
26	24-1-2	52
28	24-1-2	56
30	24-1-2	60
32	24-1-2	64
36	24-1-2	72
40	24-1-2	80

SOUTH BEND LATHE WORKS
SOUTH BEND, IND., U. S. A.

Double Friction Countershaft

The New Double Friction Countershaft is used for driving the lathe from the line shaft. The two Drive Pulleys are equipped with Quick Acting Friction Clutches which expand against the rim. One of these Pulleys is used for straight drive and the other for reversing the lathe through a cross belt or for another forward speed. Pressure Grease Cups lubricate the hub of the Clutch Pulleys. The Countershaft bearings have Felt Wick Oilers.

Two Speed Countershaft

Occasionally faster cutting speeds are required for machining Brass, Bronze, Aluminum, etc. We develop this greater speed through the Countershaft by arranging it for two speeds. This is done by attaching a large pulley on the line shaft and belting it direct with one of the Friction Pulleys usually used for reversing the lathe. This gives the second or high speed on the Countershaft which doubles the number of spindle speeds of the lathe.

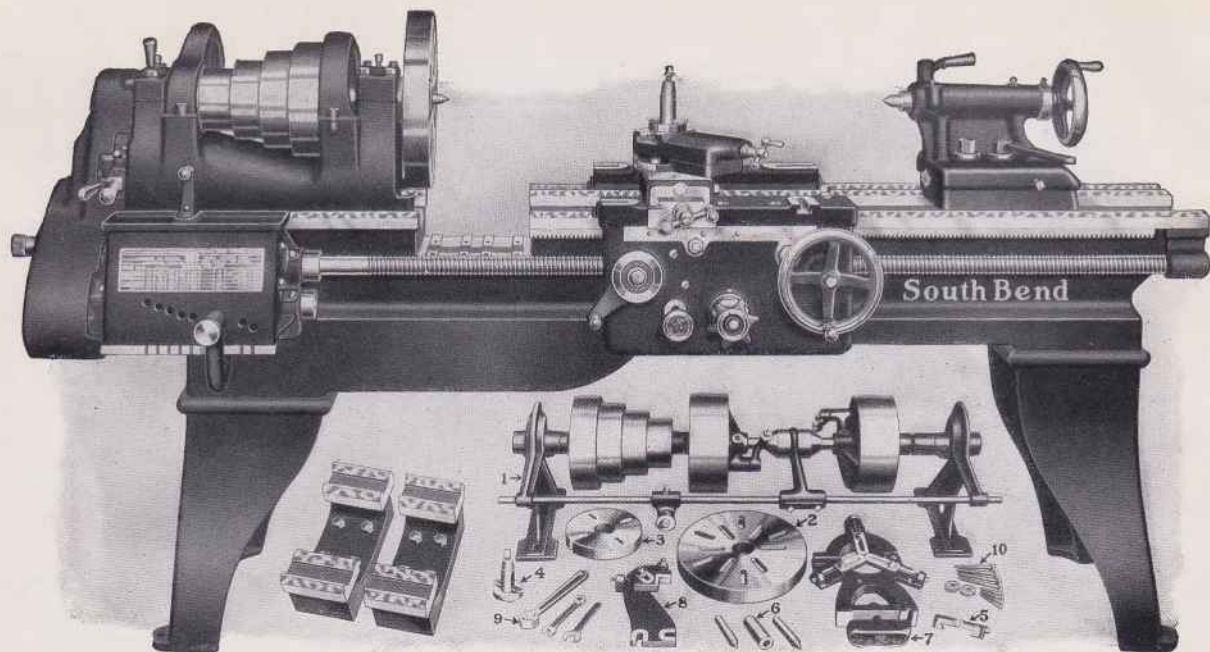

Regular equipment, as illustrated under Lathe, is included in price of Lathe

The New Model Gap Lathes with Double Bridge

Seven Sizes—11-inch to 24-inch Swing—Standard or Quick Change Gear Lathes

The Illustration Shows the new 18-26-inch Quick Change Gear Gap Lathe with Double Bridge. On Gap Lathes the control levers of the Apron are transposed so that the Carriage can be fed by hand or power over the Gap for machining narrow work.

For description of any particular size of Gap Lathe refer to a corresponding size of Straight Bed Lathe, as the only difference between the two is the construction of the Bed and Apron which are changed in the Gap Lathe construction.

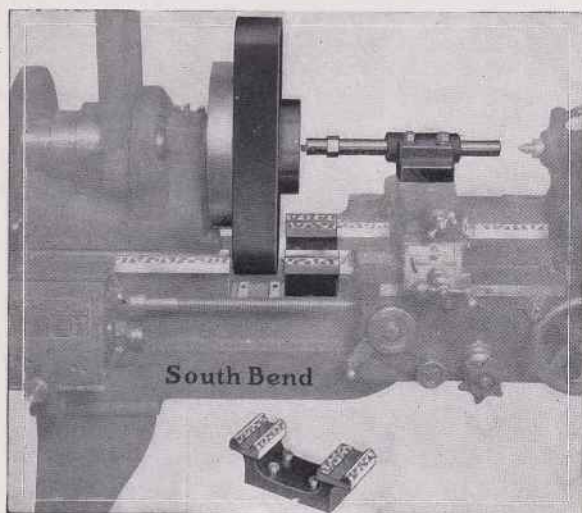

Machining Brake Drums

One Bridge Removed, the Other Remains to Support Carriage

The Double Gap Lathe with Double Bridge is an ideal machine, both for the manufacturing and servicing of brake drums on motor cars, busses and trucks of all sizes. The motor wheel with the brake drum attached is mounted in the lathe on an arbor that fits into the hub of the wheel the same as the axle. The drum can then be machined on the interior or exterior surface concentric with the axis of the hub of the wheel. This is a simple and practical method of machining brake drums with accuracy and precision.



Close-Up of Double Bridge

The Double Bridge is made up of two sections exactly the same in size and of sufficient length to completely fill the Gap in the Bed. Either one or both Bridges may be removed to accommodate the work to be machined. Each Bridge has four holes through which it is clamped to the bed of the lathe and located by Dowel Pins.

Accurately Finished and Fitted

Both Sections of the Double Bridge are very accurately finished and fitted. They are first hand scraped to each other and then to the Lathe Bed. The ways of the Bed are then machined and planed with both Bridges in place. Afterwards they are hand scraped and frosted. The Carriage is fitted to the lathe with both Bridges in place, to insure accuracy. It requires but a few moments to remove or install either one or both sections of the Double Bridge in the Lathe Bed.

The New Model Double Gap Lathes with Double Bridge

Below we show prices of the complete New Line of Gap Lathes with Double Bridge in both Standard and Quick Change Gear Types. There are seven sizes of Gap Lathes ranging from 11-inch to 24-inch swing with different Bed Lengths for each swing. The prices listed in the tabula-

tion below are Net Factory Prices, F. O. B. South Bend, crated for domestic shipment, and include Countershaft and Regular Equipment illustrated under Gap Lathe on page 34. For prices on Electrically Driven Gap Lathes, refer to page 29 covering Silent Chain Motor Drive Lathes.

Net Factory Prices and Specifications

Specifications below apply to both Quick Change Gear and Standard Change Gear Lathes							Quick Change Gear Gap Lathes			Standard Change Gear Gap Lathes		
Size of Lathe	Length of Bed	Swing Over Bed	Swing Over Gap	Total Width of Gap	Width of Each Bridge	Approx. Weight Crated	Catalog No.	Code Word	Price Quick Change Gear Lathes	Catalog No.	Code Word	Price Standard Change Gear Lathes
11-inch — 16-inch Double Gap Lathes												
11 in.	3 ft.	11¼ in.	16 in.	5 in.	2½ in.	725 lbs.	684-Y	Earls	\$ 375.00	633-Y	Efixr	\$ 340.00
11 in.	3½ ft.	11¼ in.	16 in.	5 in.	2½ in.	750 lbs.	684-Z	Ebilt	380.00	633-Z	Egoos	345.00
11 in.	4 ft.	11¼ in.	16 in.	5 in.	2½ in.	775 lbs.	684-A	Eeany	385.00	633-A	Ehbt	350.00
11 in.	5 ft.	11¼ in.	16 in.	5 in.	2½ in.	855 lbs.	684-B	Edlow	395.00	633-B	Einty	360.00
13-inch — 19-inch Double Gap Lathes												
13 in.	4 ft.	13¼ in.	19 in.	7 in.	3½ in.	1160 lbs.	686-A	Gacox	450.00	635-A	Glaze	400.00
13 in.	5 ft.	13¼ in.	19 in.	7 in.	3½ in.	1210 lbs.	686-B	Gestr	462.00	635-B	Gleta	412.00
13 in.	6 ft.	13¼ in.	19 in.	7 in.	3½ in.	1260 lbs.	686-C	Giant	474.00	635-C	Glost	424.00
13 in.	7 ft.	13¼ in.	19 in.	7 in.	3½ in.	1310 lbs.	686-D	Gleyn	486.00	635-D	Golfe	436.00
13 in.	8 ft.	13¼ in.	19 in.	7 in.	3½ in.	1360 lbs.	686-E	Gidan	498.00	635-E	Gomez	448.00
15-inch — 22-inch Double Gap Lathes												
15 in.	5 ft.	15¼ in.	22 in.	8 in.	4 in.	1600 lbs.	688-B	Lacta	545.00	639-B	Luber	485.00
15 in.	6 ft.	15¼ in.	22 in.	8 in.	4 in.	1675 lbs.	688-C	Lavor	560.00	639-C	Lucky	500.00
15 in.	7 ft.	15¼ in.	22 in.	8 in.	4 in.	1750 lbs.	688-D	Links	575.00	639-D	Ludlo	515.00
15 in.	8 ft.	15¼ in.	22 in.	8 in.	4 in.	1860 lbs.	688-E	Lotry	590.00	639-E	Lufte	530.00
15 in.	10 ft.	15¼ in.	22 in.	8 in.	4 in.	2025 lbs.	688-G	Lozen	620.00	639-G	Lynch	560.00
16-inch — 24-inch Double Gap Lathes												
16 in.	6 ft.	16¼ in.	24 in.	8¼ in.	4¾ in.	2015 lbs.	692-C	Macon	620.00	641-C	Mince	560.00
16 in.	7 ft.	16¼ in.	24 in.	8¼ in.	4¾ in.	2095 lbs.	692-D	Maids	635.00	641-D	Mouse	575.00
16 in.	8 ft.	16¼ in.	24 in.	8¼ in.	4¾ in.	2175 lbs.	692-E	Medic	650.00	641-E	Month	590.00
16 in.	10 ft.	16¼ in.	24 in.	8¼ in.	4¾ in.	2335 lbs.	692-G	Melte	680.00	641-G	Mytha	620.00
16 in.	12 ft.	16¼ in.	24 in.	8¼ in.	4¾ in.	2495 lbs.	692-H	Mezto	725.00	641-H	Mykro	665.00
18-inch — 26-inch Double Gap Lathes												
18 in.	6 ft.	18¼ in.	26 in.	10 in.	5 in.	2610 lbs.	694-C	Sabin	740.00	643-C	Seaso	675.00
18 in.	7 ft.	18¼ in.	26 in.	10 in.	5 in.	2710 lbs.	694-D	Salty	765.00	643-D	Sebal	700.00
18 in.	8 ft.	18¼ in.	26 in.	10 in.	5 in.	2810 lbs.	694-E	Sande	790.00	643-E	Sedri	725.00
18 in.	10 ft.	18¼ in.	26 in.	10 in.	5 in.	3010 lbs.	694-G	Saint	840.00	643-G	Sefol	775.00
18 in.	12 ft.	18¼ in.	26 in.	10 in.	5 in.	3310 lbs.	694-H	Savort	905.00	643-H	Segme	840.00
18 in.	14 ft.	18¼ in.	26 in.	10 in.	5 in.	3710 lbs.	694-K	Sawte	965.00	643-K	Sekda	900.00
21-inch — 30-inch Double Gap Lathes												
21 in.	7 ft.	21¼ in.	30 in.	12 in.	6 in.	3740 lbs.	696-D	Tabey	1075.00	649-D	Tears	995.00
21 in.	8 ft.	21¼ in.	30 in.	12 in.	6 in.	3940 lbs.	696-E	Tacit	1105.00	649-E	Tebik	1025.00
21 in.	10 ft.	21¼ in.	30 in.	12 in.	6 in.	4190 lbs.	696-G	Taden	1165.00	649-G	Tecor	1085.00
21 in.	12 ft.	21¼ in.	30 in.	12 in.	6 in.	4550 lbs.	696-H	Tafly	1240.00	649-H	Tedia	1160.00
21 in.	14 ft.	21¼ in.	30 in.	12 in.	6 in.	4770 lbs.	696-K	Taged	1300.00	649-K	Tefin	1220.00
24-inch — 36-inch Double Gap Lathes												
24 in.	8 ft.	24¼ in.	36 in.	15 in.	7½ in.	4840 lbs.	698-E	Wably	1455.00	657-E	Weave	1355.00
24 in.	10 ft.	24¼ in.	36 in.	15 in.	7½ in.	5090 lbs.	698-G	Wacke	1535.00	657-G	Webed	1435.00
24 in.	12 ft.	24¼ in.	36 in.	15 in.	7½ in.	5490 lbs.	698-H	Wades	1635.00	657-H	Wedna	1535.00
24 in.	14 ft.	24¼ in.	36 in.	15 in.	7½ in.	5760 lbs.	698-K	Wafle	1715.00	657-K	Wefto	1615.00
24 in.	16 ft.	24¼ in.	36 in.	15 in.	7½ in.	6040 lbs.	698-M	Wagun	1795.00	657-M	Wegnir	1695.00

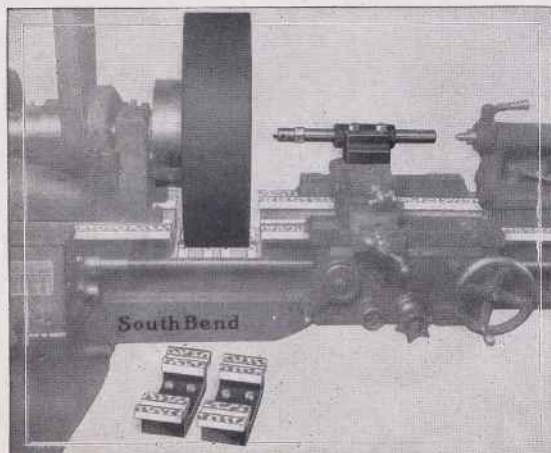

Double Bridge Removed from Gap for Extremely Wide Work

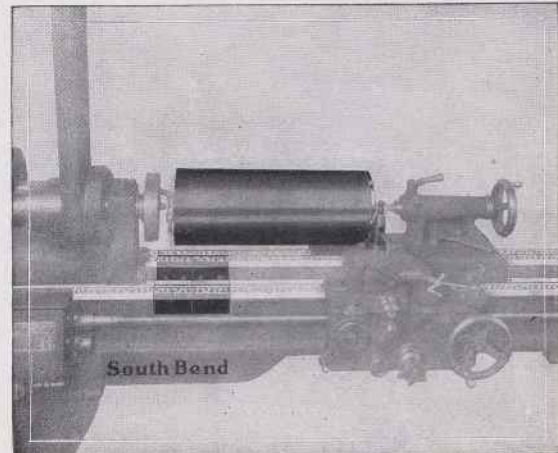

Double Bridge in Place Permits Using Lathe as a Straight Bed

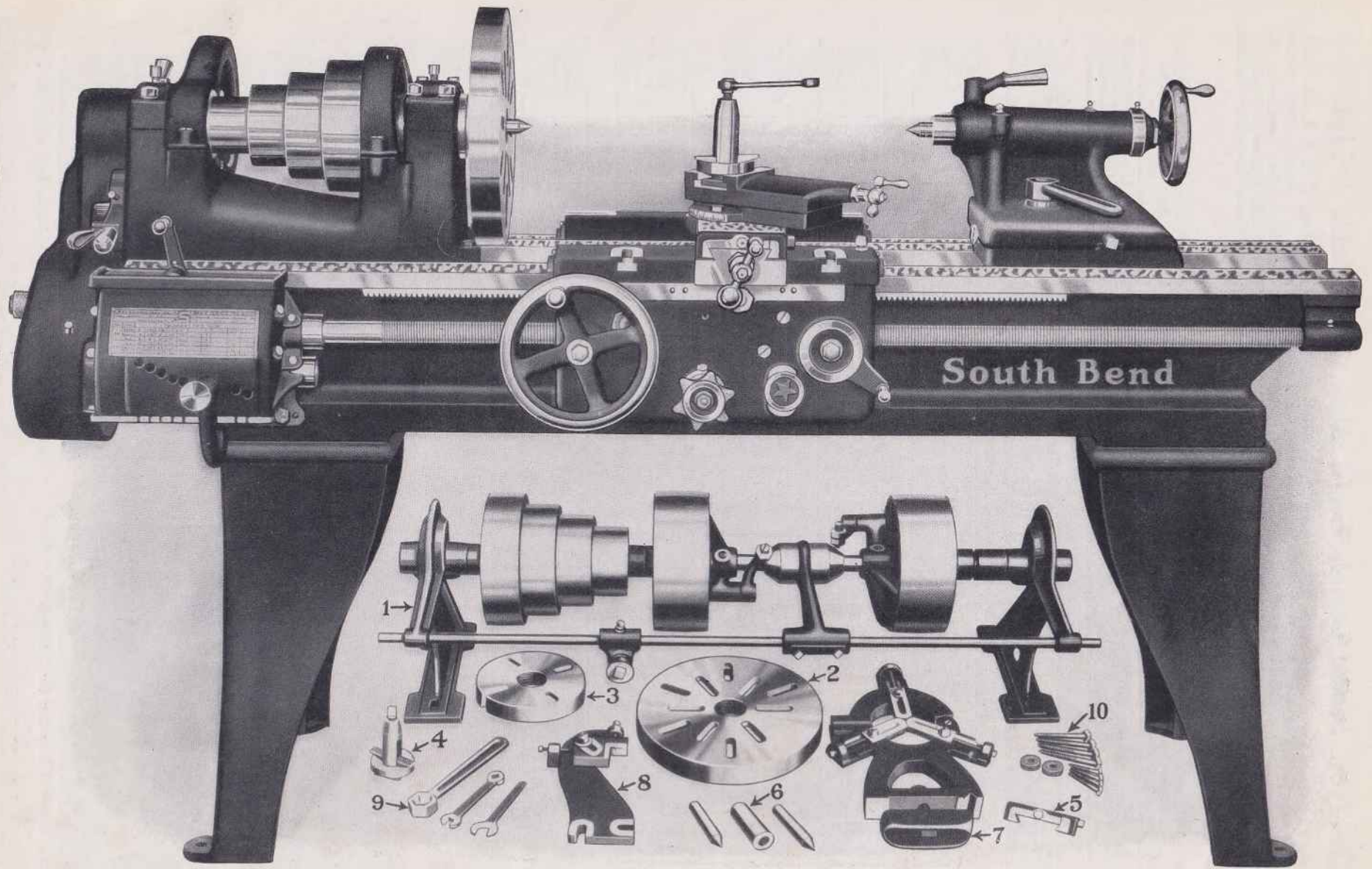

No. 92C—16" x 6' New Model Quick Change Gear Lathe—Price \$540.00

Countershaft and Equipment included in price of the Lathe

210 Sizes and Types of New Model Quick Change Gear and Standard Change Gear Lathes

Net Factory Prices F.O.B. Cars, South Bend, Indiana; Crated for Domestic Shipment

Overhead Countershaft Drive Lathes										Silent Chain Motor Drive Lathes							Gap Bed Lathes Countershaft Drive	
Swing Over Bed	Length of Bed	Distance Between Centers	Size of Hole in Spindle	Horse Power Required	Quick Change Gear		Standard Change Gear		Quick Change Gear			Standard Change Gear				Quick Change Gear Price each	Standard Change Gear Price each	
					Cat. No.	Price Each	Cat. No.	Price Each	Cat. No.	With 3 Phase 60 Cycle A.C. Motor, Price	With Single Phase 60 Cycle A.C. Motor, Price	With Direct Current Motor, Price	Cat. No.	With 3 Phase 60 Cycle A.C. Motor, Price	With Single Phase 60 Cycle A.C. Motor, Price			With Direct Current Motor, Price
9-inch New Model South Bend Screw Cutting Lathes																		
9 1/4 in.	2 1/2 ft.	11 in.	3/4 in.	1/4 H.P.	82-X	\$ 265.00	31-X	\$ 230.00	382-X	\$ 366.00	\$ 381.00	\$ 369.00	331-X	\$ 331.00	\$ 346.00	\$ 334.00	Not Made	Not Made
9 1/4 in.	3 ft.	18 in.	3/4 in.	1/4 H.P.	82-Y	270.00	31-Y	235.00	382-Y	371.00	386.00	374.00	331-Y	336.00	351.00	339.00		
9 1/4 in.	3 1/2 ft.	23 in.	3/4 in.	1/4 H.P.	82-Z	275.00	31-Z	240.00	382-Z	376.00	391.00	379.00	331-Z	341.00	356.00	344.00		
9 1/4 in.	4 ft.	29 in.	3/4 in.	1/4 H.P.	82-A	280.00	31-A	245.00	382-A	381.00	396.00	384.00	331-A	346.00	361.00	349.00		
9 1/4 in.	4 1/2 ft.	36 in.	3/4 in.	1/4 H.P.	82-R	285.00	31-R	250.00	382-R	386.00	401.00	389.00	331-R	351.00	366.00	354.00		
11-inch New Model South Bend Screw Cutting Lathes																		
11 1/4 in.	3 ft.	12 in.	7/8 in.	1/2 H.P.	84-Y	325.00	33-Y	290.00	384-Y	445.00	471.00	454.00	333-Y	410.00	436.00	419.00	\$ 375.00	\$ 340.00
11 1/4 in.	3 1/2 ft.	18 in.	7/8 in.	1/2 H.P.	84-Z	330.00	33-Z	295.00	384-Z	450.00	476.00	459.00	333-Z	415.00	441.00	424.00	380.00	345.00
11 1/4 in.	4 ft.	24 in.	7/8 in.	1/2 H.P.	84-A	335.00	33-A	300.00	384-A	455.00	481.00	464.00	333-A	420.00	446.00	429.00	385.00	350.00
11 1/4 in.	5 ft.	36 in.	7/8 in.	1/2 H.P.	84-B	345.00	33-B	310.00	384-B	465.00	491.00	474.00	333-B	430.00	456.00	439.00	395.00	360.00
13-inch New Model South Bend Screw Cutting Lathes																		
13 1/4 in.	4 ft.	16 in.	1 in.	3/4 H.P.	86-A	390.00	35-A	340.00	386-A	525.00	590.00	534.00	335-A	475.00	540.00	484.00	450.00	400.00
13 1/4 in.	5 ft.	28 in.	1 in.	3/4 H.P.	86-B	402.00	35-B	352.00	386-B	537.00	602.00	546.00	335-B	487.00	552.00	496.00	462.00	412.00
13 1/4 in.	6 ft.	40 in.	1 in.	3/4 H.P.	86-C	414.00	35-C	364.00	386-C	549.00	614.00	558.00	335-C	499.00	564.00	508.00	474.00	424.00
13 1/4 in.	7 ft.	52 in.	1 in.	3/4 H.P.	86-D	426.00	35-D	376.00	386-D	561.00	626.00	570.00	335-D	511.00	576.00	520.00	486.00	436.00
13 1/4 in.	8 ft.	64 in.	1 in.	3/4 H.P.	86-E	438.00	35-E	388.00	386-E	573.00	638.00	582.00	335-E	523.00	588.00	532.00	498.00	448.00
15-inch New Model South Bend Screw Cutting Lathes																		
15 1/4 in.	5 ft.	24 1/2 in.	1 1/8 in.	1 H.P.	88-B	475.00	39-B	415.00	388-B	628.00	701.00	707.00	339-B	568.00	641.00	647.00	545.00	485.00
15 1/4 in.	6 ft.	36 1/2 in.	1 1/8 in.	1 H.P.	88-C	490.00	39-C	430.00	388-C	643.00	716.00	722.00	339-C	583.00	656.00	662.00	560.00	500.00
15 1/4 in.	7 ft.	48 1/2 in.	1 1/8 in.	1 H.P.	88-D	505.00	39-D	445.00	388-D	658.00	731.00	737.00	339-D	598.00	671.00	677.00	575.00	515.00
15 1/4 in.	8 ft.	60 1/2 in.	1 1/8 in.	1 H.P.	88-E	520.00	39-E	460.00	388-E	673.00	746.00	752.00	339-E	613.00	686.00	692.00	590.00	530.00
15 1/4 in.	10 ft.	84 1/2 in.	1 1/8 in.	1 H.P.	88-G	550.00	39-G	490.00	388-G	703.00	776.00	782.00	339-G	643.00	716.00	722.00	620.00	560.00
16-inch New Model South Bend Screw Cutting Lathes																		
16 1/4 in.	6 ft.	34 in.	1 3/8 in.	1 H.P.	92-C	540.00	41-C	480.00	392-C	695.00	768.00	774.00	341-C	635.00	708.00	714.00	620.00	560.00
16 1/4 in.	7 ft.	46 in.	1 3/8 in.	1 H.P.	92-D	555.00	41-D	495.00	392-D	710.00	783.00	789.00	341-D	650.00	723.00	729.00	635.00	575.00
16 1/4 in.	8 ft.	58 in.	1 3/8 in.	1 H.P.	92-E	570.00	41-E	510.00	392-E	725.00	798.00	804.00	341-E	665.00	738.00	744.00	650.00	590.00
16 1/4 in.	10 ft.	82 in.	1 3/8 in.	1 H.P.	92-G	600.00	41-G	540.00	392-G	755.00	828.00	834.00	341-G	695.00	768.00	774.00	680.00	620.00
16 1/4 in.	12 ft.	106 in.	1 3/8 in.	1 H.P.	92-H	645.00	41-H	585.00	392-H	800.00	873.00	879.00	341-H	740.00	813.00	819.00	725.00	665.00
18-inch New Model South Bend Screw Cutting Lathes																		
18 1/4 in.	6 ft.	29 1/2 in.	1 7/8 in.	2 H.P.	94-C	650.00	43-C	585.00	394-C	858.00	972.00	970.00	343-C	793.00	907.00	905.00	740.00	675.00
18 1/4 in.	7 ft.	41 1/2 in.	1 7/8 in.	2 H.P.	94-D	675.00	43-D	610.00	394-D	883.00	997.00	995.00	343-D	818.00	932.00	930.00	765.00	700.00
18 1/4 in.	8 ft.	53 1/2 in.	1 7/8 in.	2 H.P.	94-E	700.00	43-E	635.00	394-E	908.00	1022.00	1020.00	343-E	843.00	957.00	955.00	790.00	725.00
18 1/4 in.	10 ft.	77 1/2 in.	1 7/8 in.	2 H.P.	94-G	750.00	43-G	685.00	394-G	958.00	1072.00	1070.00	343-G	893.00	1007.00	1005.00	840.00	775.00
18 1/4 in.	12 ft.	101 1/2 in.	1 7/8 in.	2 H.P.	94-H	815.00	43-H	750.00	394-H	1023.00	1137.00	1135.00	343-H	958.00	1072.00	1070.00	905.00	840.00
18 1/4 in.	14 ft.	125 1/2 in.	1 7/8 in.	2 H.P.	94-K	875.00	43-K	810.00	394-K	1083.00	1197.00	1195.00	343-K	1018.00	1132.00	1130.00	965.00	900.00
21-inch New Model South Bend Screw Cutting Lathes																		
21 1/4 in.	7 ft.	36 in.	1 1/2 in.	3 H.P.	96-D	950.00	49-D	870.00	396-D	1254.00	1388.00	1413.00	349-D	1174.00	1308.00	1333.00	1075.00	995.00
21 1/4 in.	8 ft.	48 in.	1 1/2 in.	3 H.P.	96-E	980.00	49-E	900.00	396-E	1284.00	1418.00	1443.00	349-E	1204.00	1338.00	1363.00	1105.00	1025.00
21 1/4 in.	10 ft.	72 in.	1 1/2 in.	3 H.P.	96-G	1040.00	49-G	960.00	396-G	1344.00	1478.00	1503.00	349-G	1264.00	1398.00	1423.00	1165.00	1085.00
21 1/4 in.	12 ft.	96 in.	1 1/2 in.	3 H.P.	96-H	1115.00	49-H	1035.00	396-H	1419.00	1553.00	1578.00	349-H	1339.00	1473.00	1498.00	1240.00	1160.00
21 1/4 in.	14 ft.	120 in.	1 1/2 in.	3 H.P.	96-K	1175.00	49-K	1095.00	396-K	1479.00	1613.00	1638.00	349-K	1399.00	1533.00	1558.00	1300.00	1220.00
24-inch New Model South Bend Screw Cutting Lathes																		
24 1/4 in.	8 ft.	43 in.	1 3/4 in.	3 H.P.	98-E	1280.00	57-E	1180.00	398-E	1634.00	1767.00	1793.00	357-E	1534.00	1667.00	1693.00	1455.00	1355.00
24 1/4 in.	10 ft.	67 in.	1 3/4 in.	3 H.P.	98-G	1360.00	57-G	1260.00	398-G	1714.00	1847.00	1873.00	357-G	1614.00	1747.00	1773.00	1535.00	1435.00
24 1/4 in.	12 ft.	91 in.	1 3/4 in.	3 H.P.	98-H	1460.00	57-H	1360.00	398-H	1814.00	1947.00	1973.00	357-H	1714.00	1847.00	1873.00	1635.00	1535.00
24 1/4 in.	14 ft.	115 in.	1 3/4 in.	3 H.P.	98-K	1540.00	57-K	1440.00	398-K	1894.00	2027.00	2053.00	357-K	1794.00	1927.00	1953.00	1715.00	1615.00
24 1/4 in.	16 ft.	139 in.	1 3/4 in.	3 H.P.	98-M	1620.00	57-M	1520.00	398-M	1974.00	2107.00	2133.00	357-M	1874.00	2007.00	2033.00	1795.00	1695.00



Hand Wheel Type Draw-in Collet Chuck Attachment

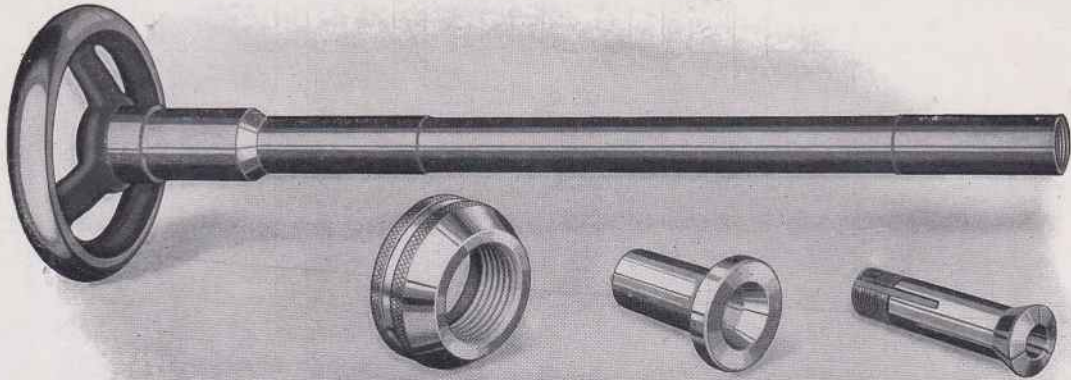

What the Hand Wheel Type Consists of

The Hand Wheel Draw-in Collet Chuck Attachment consists of a Split Collet, ground inside and outside, a Taper Sleeve into which the Collet fits, a Hand Wheel and Hollow Draw-tube which enters the Lathe spindle from the rear end and screws on thread of Collet Chuck to tighten or release the work, and a Knock-off Nut threaded to fit the spindle nose of Lathe and used to remove the Taper Sleeve and Collet from the spindle. In the illustration above we show the various parts which make up the Hand Wheel Type Draw-in Collet Chuck Attachment.

How the Hand Wheel Type Draw-in Collet Chuck Operates

The Hand Wheel, mounted on the end of the Draw-tube, is used to operate the Collet, causing it to tighten or release on the work as the threads in the end of tube draw the Collet into the Taper Sleeve in the Lathe Spindle. The Split Collet which holds the work is made of tool steel, hardened, tempered and ground both outside and inside to insure accuracy. The Knock-off Nut protects the threads of the Spindle Nose, and is also used to remove the Taper Sleeve from the head spindle.

Made in Eight Sizes

The Hand Wheel Draw-in Collet Chuck is made in eight different sizes to conform to the eight different sizes of South Bend Lathes. The capacity of the Hand Wheel Draw-in Collet Chuck is limited by the size of the hole in the lathe spindle.

What the Price Includes

The price of the Hand Wheel Draw-in Collet Chuck Attachment includes Hand Wheel and Draw-tube threaded to receive Collet, Nose Cap for protecting threads of Spindle Nose, Tapered Steel Sleeve for adapting Collet to Head Stock Spindle, and one Round Split Collet of any size desired up to the maximum capacity of Lathe Spindle.

Specifications and Net Factory Prices

Size of Lathe	Catalog No.	Hole in Lathe Spindle	Collet Capacity in Sixty-fourths	Code Words	Price Each
9 in.	4309	3/8 in.	1/8 in. up to 1/8 in.	Aaron	\$33.00
11 in.	4311	7/8 in.	1/8 in. up to 9/16 in.	Abode	38.00
13 in.	4313	1 in.	1/8 in. up to 5/8 in.	About	44.00
15 in.	4315	1 1/8 in.	1/8 in. up to 3/4 in.	Above	50.00
16 in.	4316	1 3/8 in.	1/8 in. up to 7/8 in.	Adore	56.00
18 in.	4318	1 7/8 in.	1/8 in. up to 1 in.	Adult	63.00
21 in.	4321	1 1/2 in.	1/8 in. up to 1 1/8 in.	Akron	80.00
24 in.	4324	1 3/4 in.	1/8 in. up to 1 3/8 in.	Alarm	90.00

Application of the Hand Wheel Draw-in Collet Chuck

The illustration at right shows a South Bend Lathe equipped with a Hand Wheel Draw-in Collet Chuck for handling fine, accurate parts. The work is held in the Collet Chuck by turning the Hand Wheel to the right and released by turning it to the left. With the Hand Wheel Draw-in Collet Chuck, it is necessary to stop the lathe spindle to grip or release the work.

For Tool Room Work

The Hand Wheel Type Draw-in Collet Chuck Attachment is used extensively where small work must be produced in quantity and in the Tool Room where accuracy is essential. It is a fine precision tool and the most accurate type of chuck on the market.

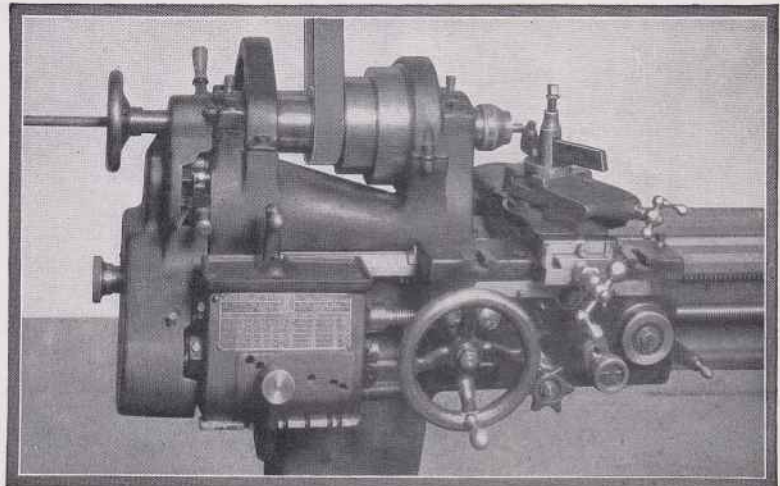

Machining Special Pins in the Draw-in Collet Chuck

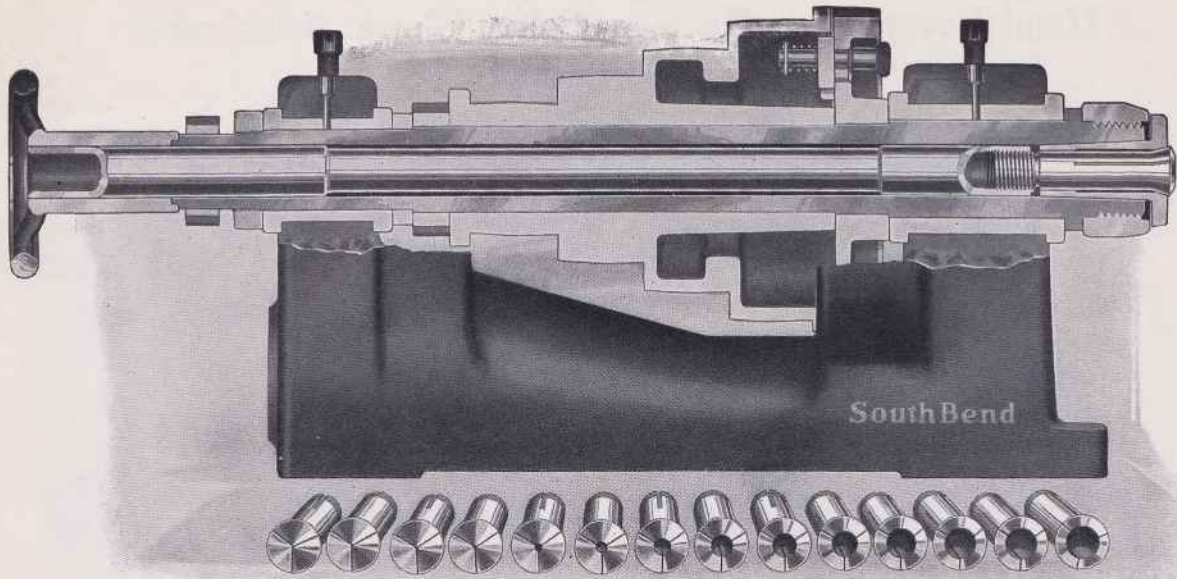

Split Collets for Draw-in Chuck Attachments

The illustration shows a cross section of the Head Stock of a South Bend Lathe fitted with a Hand Wheel Draw-in Collet Chuck.

The hole capacity of the Draw-in Collet Chuck for any size of South Bend Lathe is limited by the size of the hole in the spindle. See tabulation below. One Collet only is included in the price of either the Hand Wheel or Hand Lever type of Draw-in Collet Chuck Attachment.

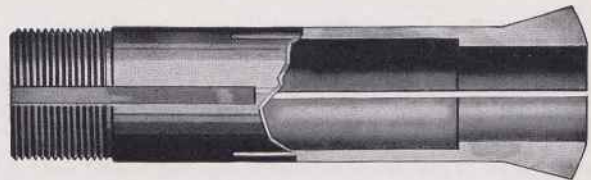

Construction of Split Collets

All Collets are made of tool steel, hardened and tempered. They are ground both outside and inside to insure accuracy. The left end is threaded for the draw-tube and has a keyway to prevent the Collet from turning while holding work.

Standard Collets for Round Work

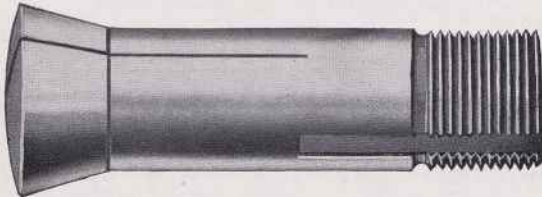

For Either Type of Draw-in Collet Chuck

When ordering extra Collets for either the Hand Wheel or Hand Lever type of Draw-in Chuck Attachments specify size of hole in Collet and size of Lathe for which Collet is wanted.

Size of Hole in Collets

Collets from $\frac{1}{8}$ -inch hole diameter to hole capacity shown in the tabulation, by 64ths, 32nds, and 16ths are regularly carried in stock. Special hole sizes such as odd decimal, drill and wire gauge, and metric sizes can be furnished as required.

Net Factory Prices of Split Collets for Round Work

Size of Lathe	Catalog No.	Hole in Lathe Spindle	Collet Capacity in Sixty-fourths	Code Word	Price Each
9 in.	609	$\frac{3}{8}$ in.	$\frac{1}{8}$ in. up to $\frac{1}{2}$ in.	Cabot	\$3.50
11 in.	611	$\frac{7}{8}$ in.	$\frac{1}{8}$ in. up to $\frac{3}{8}$ in.	Cello	4.00
13 in.	613	1 in.	$\frac{1}{8}$ in. up to $\frac{3}{8}$ in.	Chose	4.50
15 in.	615	$1\frac{1}{8}$ in.	$\frac{1}{8}$ in. up to $\frac{3}{8}$ in.	Civit	5.00
16 in.	616	$1\frac{1}{8}$ in.	$\frac{1}{8}$ in. up to $\frac{3}{8}$ in.	Clear	5.50
18 in.	618	$1\frac{1}{8}$ in.	$\frac{1}{8}$ in. up to 1 in.	Comet	6.00
21 in.	621	$1\frac{1}{2}$ in.	$\frac{1}{8}$ in. up to $1\frac{1}{8}$ in.	Crust	7.00
24 in.	624	$1\frac{3}{4}$ in.	$\frac{1}{8}$ in. up to $1\frac{3}{8}$ in.	Curse	8.00

*No. 609 $\frac{1}{2}$ —Special Collet for 9-inch lathe with $\frac{1}{8}$ -inch hole in front end for holding Jewelers' Plunger Blanks, Price each F.O.B. South Bend. Code Word, Cabin.....\$3.75

Three Different Types of Split Collets

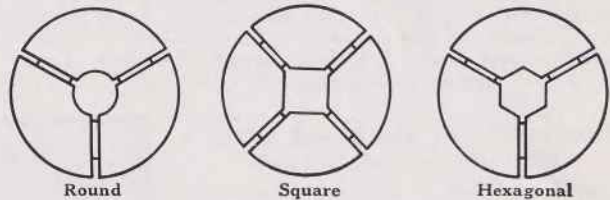

The illustrations above show the three different types of Split Collets used to hold Round, Square, or Hexagonal Stock. Round Collets only are carried in stock by us. Square and Hexagonal are made to order and are priced on request.

Step Chucks and Closer

Either the Hand Wheel or the Quick Acting Hand Lever Type Draw-in Collet Chuck Attachment can be equipped with Step Chuck and Closer, as illustrated at left. The Step Chuck is very useful for holding round discs, small gear blanks, piston rings, etc. The steps can be readily machined to receive the work to be held. Prices furnished upon application.





Hand Lever Type Draw-in Collet Chuck Attachment

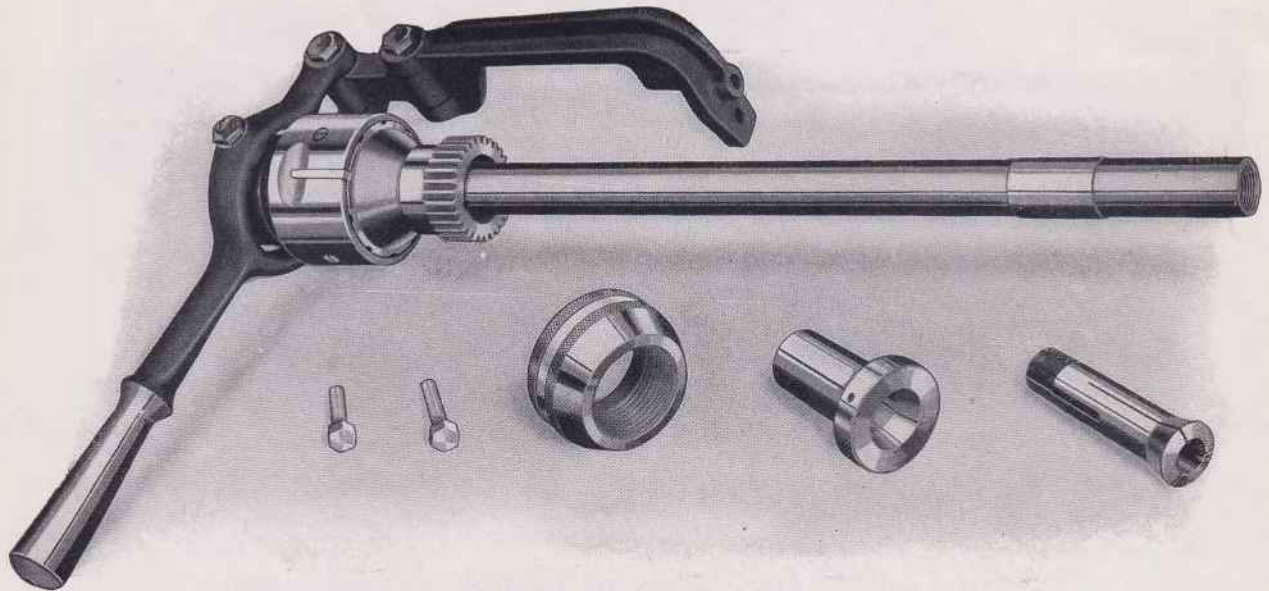

Must be Fitted to Lathe at Factory

What the Hand Lever Type Consists of

The Hand Lever Draw-in Collet Chuck consists of one Split Collet ground inside and outside, a Taper Sleeve into which the Collet fits, a Hand Lever and Draw-tube which permits opening and closing the Collet on the work while the Lathe Spindle is revolving, and a Knock-off Nut threaded to fit the Spindle Nose of the Lathe and used to remove the Taper Sleeve and Collet from the Spindle. This Attachment must be fitted to lathe at factory.

Made in Eight Sizes

The Hand Lever Draw-in Collet Chuck is made in eight sizes to fit the eight different sizes of South Bend Lathes.

What the Price Includes

The price includes Steel Draw-tube with Hand Lever and Clutch, Nose Cap for protecting threads of Lathe Spindle, Steel Taper Sleeve bored to conform with the Split Collet, and one Round Split Collet, any size desired, up to the maximum capacity of Lathe Spindle.

How the Hand Lever Type Draw-in Collet Chuck Operates

The Hand Lever Draw-in Collet Chuck permits releasing and feeding the bar stock without stopping the lathe. This is accomplished by means of an Adjustable Chuck Closer. The gripping action of the Collet can be adjusted to any desired tension on the work by regulating the Cylinder of the Adjustable Chuck Closer, which is notched and keyed for that purpose. Collets of any size, up to maximum capacity, can be used.

Specifications and Net Factory Prices

Size of Lathe	Catalog No.	Hole in Lathe Spindle	Collet Capacity in Sixty-fourths	Code Words	Price Each
9 in.	5209	3/4 in.	1/16 in. up to 1/8 in.	Allen	\$ 75.00
11 in.	5211	7/8 in.	1/16 in. up to 1/8 in.	Among	85.00
13 in.	5213	1 in.	1/16 in. up to 1/8 in.	Andes	105.00
15 in.	5215	1 1/8 in.	1/16 in. up to 3/8 in.	Askew	110.00
16 in.	5216	1 3/8 in.	1/16 in. up to 7/8 in.	Aster	120.00
18 in.	5218	1 7/8 in.	1/16 in. up to 1 in.	Atoll	160.00
21 in.	5221	1 1/2 in.	1/16 in. up to 1 1/4 in.	Always	180.00
24 in.	5224	1 3/4 in.	1/16 in. up to 1 3/8 in.	Azure	200.00

Application of the Hand Lever Draw-in Collet Chuck

The illustration at the right shows a South Bend Lathe equipped with a Hand Lever Type Draw-in Collet Chuck Attachment for the production of small parts in large quantities. The work is gripped in the Collet by throwing the Hand Lever to the left and released by swinging it to the right.

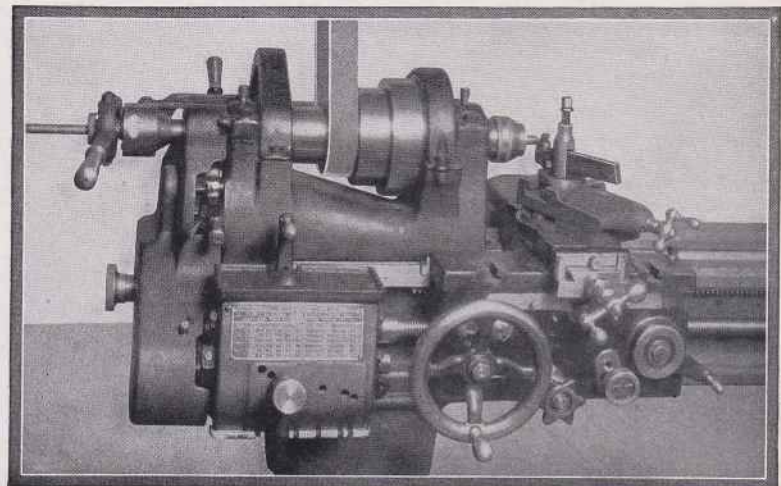

Manufacturing Small Screws with Hand Lever Draw-in Collet Chuck

For Rapid Production Work

The rapid production and accuracy of the Hand Lever Draw-in Collet Chuck Attachment makes it a very economical tool for use in the manufacturing of small interchangeable parts where accuracy and precision are required. The capacity of the Hand Lever Draw-in Collet Chuck Attachment is limited by the diameter of the hole in the head spindle of the lathe.



Graduated Taper Attachment for South Bend Lathes

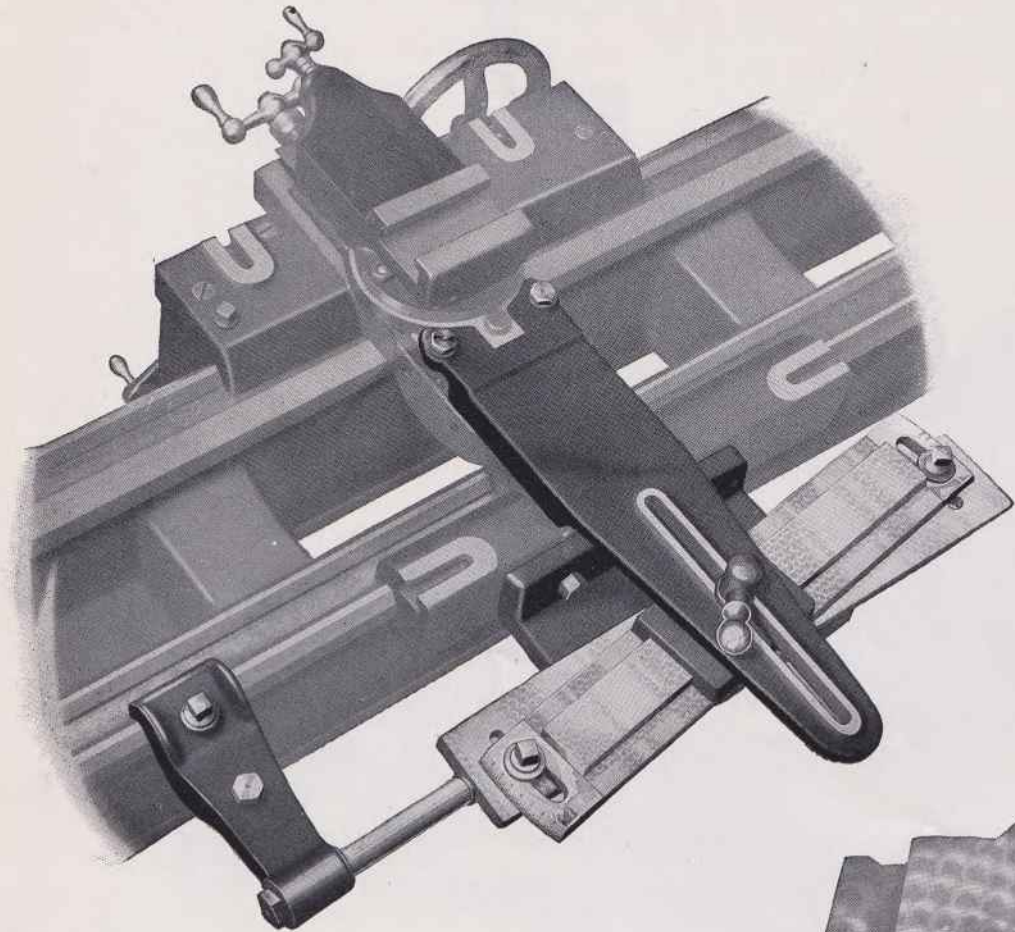

Illustration taken from the rear side of lathe, shows Taper Attachment bolted to the back of Saddle and clamped to the rear V-way of bed.

Graduated Taper Attachment Fitted to a 16-inch South Bend Lathe

The Taper Attachment is used for turning and boring all classes of tapered work, such as automobile axles, drive shafts, hubs, pipe threads, clutch drums, etc. A great deal of time is saved with this attachment, due to the fact that it is not necessary to off-set the Tail Stock center for taper turning. The Attachment may be left on the lathe at all times, whether straight or tapered work is to be done.

Can Be Operated Entire Length of Bed

The Taper Attachment is bolted to the Lathe carriage and can be set for taper turning or boring at any position along the entire length of the lathe bed. The Taper Attachment does not interfere with straight turning as it does not operate unless the clamp on the back "V" of the bed is locked.

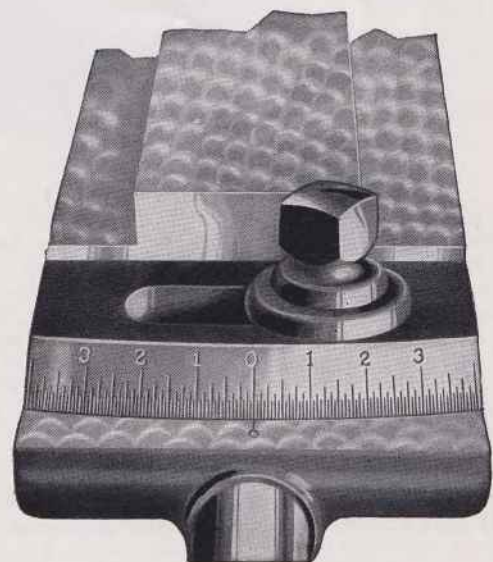

Close-up of Graduation

The Swivel Bar, which controls the Taper, is graduated—one end in inches per foot of taper and the other end in degrees. The attachment can be set for any Taper up to 3 inches per foot. It is advisable to order the Taper Attachment with the lathe, so that it can be fitted at the factory; although it may be ordered at any time and attached by the customer, as the saddle is machined to receive it.

Net Factory Prices

Size of Lathe	Catalog No.	Maximum Taper at One Setting	Maximum Taper Per Foot	Maximum Taper in Degrees	Approximate Shipping Weight	Code Words	Price Taper Attachment
9 in.	209	9 in.	3 in.	14	40 lbs.	Dashe	\$ 50.00
11 in.	211	9 in.	3 in.	14	50 lbs.	Devor	60.00
13 in.	213	10 in.	3 in.	14	65 lbs.	Digit	70.00
15 in.	215	10 in.	3 in.	14	80 lbs.	Doted	75.00
16 in.	216	12 in.	3 in.	14	100 lbs.	Dress	85.00
18 in.	218	12 in.	3 in.	14	120 lbs.	Dunns	90.00
21 in.	221	14 in.	3 in.	14	140 lbs.	Dwind	100.00
24 in.	224	14 in.	3 in.	14	150 lbs.	Dyght	125.00



Milling and Keyway Cutting Attachment for South Bend Lathes

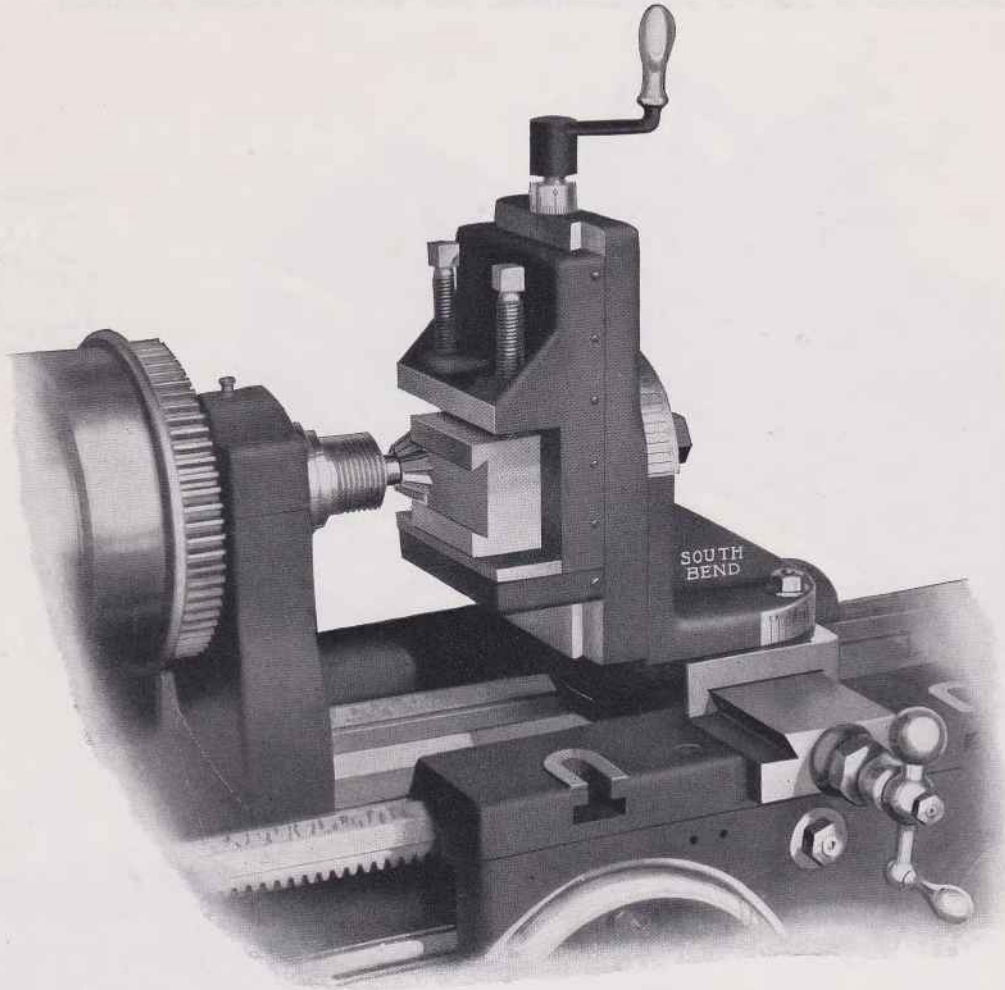

Takes Care of a Wide Variety of Machine Work

The South Bend Milling and Keyway Cutting Attachment is valuable for the small shop because it equips the lathe for doing a great deal of work that otherwise could be done only on a shaper or milling machine. It will be appreciated by the experienced mechanic because in addition to cutting keyways a wide variety of machine work can be taken care of. A few of the various jobs that show the application of the attachment are illustrated on page 43.

Fits on Saddle of Lathe

The Milling and Keyway Cutting Attachment fits on the saddle of the lathe, swivels all the way around in a horizontal plane like the compound rest and is graduated

180 degrees. In addition, the upright Angle Plate to which the vise is attached swivels in a vertical plane, and is graduated 180 degrees. The vertical adjusting screw at the top of the attachment is equipped with a micrometer graduated collar. The automatic cross and longitudinal feeds of the carriage can be used as well as the hand feeds.

Regular Equipment for Milling Attachment

The equipment consists of milling attachment, two steel "V" blocks for holding round work, one crank handle for feed screw, one double end wrench, T-bolts and nuts for attaching to carriage. The Milling Arbor and Cutters are not included in the price of the Milling Attachment. For prices on Arbor and Cutters see page 44.

Net Factory Prices Including Regular Equipment

Size of Attachment	Size of Lathe	Vertical Feed	Cross Feed	Vise Will Hold	Depth of Jaws	Width of Jaws	Width of Base	Weight Each	Code Word	Price Each
No. 1	9 in.	2½ in.	3 in.	1½ in.	1 in.	3 in.	3¼ in.	25 lbs.	Vagon	\$36.00
No. 2	11 in.	3 in.	4 in.	1½ in.	1 in.	3½ in.	3¾ in.	30 lbs.	Valet	40.00
No. 3	13 in.	5 in.	8 in.	2½ in.	1½ in.	5 in.	5 in.	40 lbs.	Victo	45.00
No. 4	15 in.	6 in.	10 in.	3½ in.	1¾ in.	5½ in.	5½ in.	50 lbs.	Visit	50.00
No. 5	16 in.	7 in.	11 in.	4 in.	2 in.	6 in.	6 in.	65 lbs.	Volts	55.00
No. 5½	18 in.	7 in.	14 in.	4 in.	2 in.	6 in.	6 in.	75 lbs.	Voxar	65.00
No. 6	21 in.	8 in.	15 in.	4½ in.	2½ in.	7 in.	7½ in.	80 lbs.	Vurry	80.00
No. 7	24 in.	10 in.	20 in.	5 in.	2½ in.	8 in.	8 in.	100 lbs.	Vusel	90.00



Practical Jobs for the Milling Attachment on the Lathe

A Screw Cutting Lathe fitted with a Milling and Keyway Cutting Attachment and using various types of milling cutters makes an excellent equipment for the small shop that has not enough of this class of work to invest in an expensive milling machine.

The skilled mechanic can use the Milling Attachment on the lathe for hundreds of different kinds of jobs, both in tool and production work.

The milling arbors and cutters that are used with the Milling Attachment are illustrated and priced on page 44 of this catalog. If milling cutters, other than those shown, are wanted, we will be pleased to furnish illustrations, description and prices on request.

The Milling and Keyway Cutting Attachment is designed for use on South Bend Lathes, and therefore, we cannot guarantee that it can be fitted to lathes of other makes.

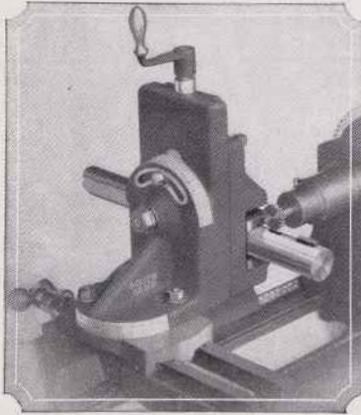

Milling a Woodruff Keyway

Woodruff System Keyways are milled with special milling cutters. These cutters have a 1/2-inch straight shank and are held in a special collet chuck. The shaft is clamped between the "V" blocks of the milling attachment and is fed vertically against the revolving cutter by turning the crank at the top.

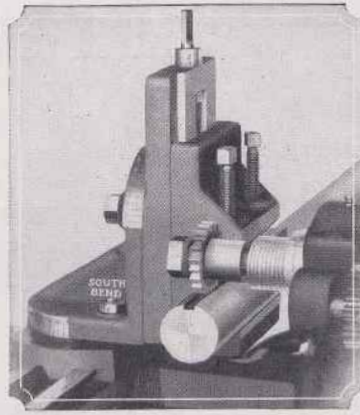

Milling a Standard Keyway

The illustration above is taken from the back of the lathe and shows the application of a South Bend Milling Attachment cutting a 3/8-inch keyway in a 2-inch shaft. If a keyway is to be milled in a taper shaft, the milling attachment vise is swiveled to the proper angle.

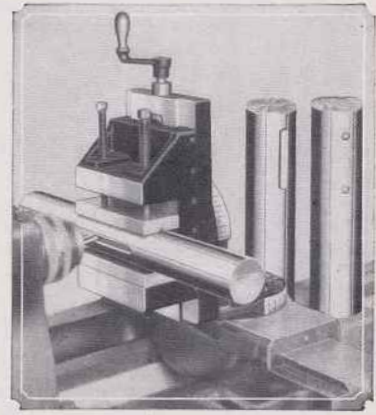

Milling a Keyway in Shaft

A pilot hole is first drilled to the proper depth at each end of the keyway for starting and ending the cut. A small straight-shank end mill held in a drill chuck in the spindle is used to cut the keyway between the two drilled holes. The automatic cross feed of the carriage is used to feed the work.

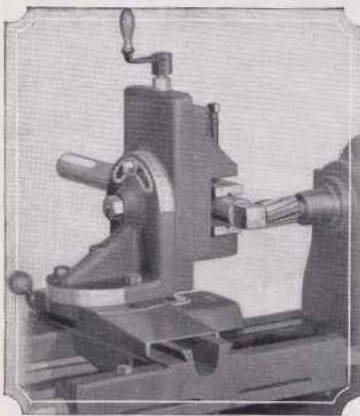

Squaring a Steel Shaft

A Spiral End Mill is held in the spindle of the lathe—the depth of the cut being adjusted by the longitudinal feed of the lathe carriage. The vertical feed of the milling attachment or the cross feed of the lathe is then used to feed the shaft across the cutter.

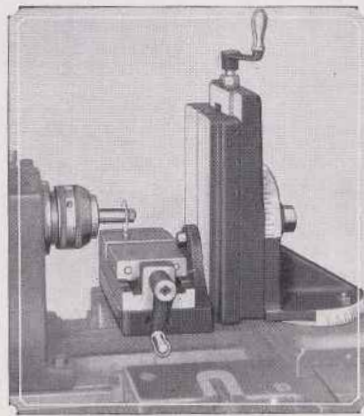

Horizontal Vise Fixture

The illustration shows milling attachment fitted with a horizontal vise fixture for milling small parts in large quantities on the lathe. The fixture is not included in the price of the milling attachment but is extra. Prices quoted on request.

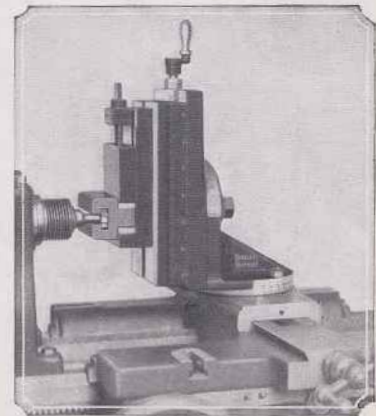

Vertical Vise Fixture

The illustration shows a piece of work that is being milled while being held in a vise on the milling attachment. This is a handy fixture for fine tool work. This fixture is not included in the price of the milling attachment but is extra. Prices quoted on request.

Milling Cutters and Arbors for South Bend Lathes

Arbor for Side and Plain Milling Cutters



For holding cutters with standard 1-in. hole. Capacity between nut and shoulder is 1½ in. Three spacing collars and hardened

nut are furnished with each arbor. The Taper Shank is ground to fit the head spindle of the lathe.

Net Factory Prices

Size Lathe	Cat. No.	Morse Taper	Code Word	Price Each	Size Lathe	Cat. No.	Morse Taper	Code Word	Price Each
9 in.	109	No. 2	Kacel	\$8.00	16 in.	116	No. 3	Kempy	\$10.00
11 in.	111	No. 2	Kbosh	8.00	18 in.	118	No. 3	Kferd	10.00
13 in.	113	No. 3	Keite	9.00	21 in.	121	No. 4	Kguzt	11.00
15 in.	115	No. 3	Kdoxl	9.00	24 in.	124	No. 4	Khans	11.00

Special Collet Chuck for Woodruff Cutters



The Collet Chuck holds Woodruff Milling Cutters with straight shank ½ inch in diameter. Taper Shank fits head spindle of lathe. Cutter is not included in price of arbor.

Net Factory Prices

Size Lathe	Catalog No.	Code Word	Price Each	Size Lathe	Catalog No.	Code Word	Price Each
9 in.	101	Rabet	\$8.00	16 in.	105	Rsyma	\$8.00
11 in.	102	Resta	8.00	18 in.	106	Rusty	8.00
13 in.	103	Ritho	8.00	21 in.	107	Ryhis	9.00
15 in.	104	Rodny	8.00	24 in.	108	Rziaz	9.00



Plain Milling Cutters

Made of High Speed steel, properly hardened and ground. Will cut on face only. All cutters have 1-inch hole and standard keyway.

Net Factory Prices

Catalog No.	Width of Face	Diameter of Cutter	Diameter of Hole	Code Word	Price Each
849-A	¾ in.	2½ in.	1 in.	Naber	\$3.25
849-B	¾ in.	2½ in.	1 in.	Nbokt	3.50
849-C	¾ in.	2½ in.	1 in.	Neerl	3.75
849-D	¾ in.	2½ in.	1 in.	Ndixo	4.00
849-E	¾ in.	2½ in.	1 in.	Nedop	4.25
849-F	¾ in.	2½ in.	1 in.	Nfenz	4.50
849-G	¾ in.	2½ in.	1 in.	Ngard	4.80
849-H	¾ in.	2½ in.	1 in.	Nhabx	5.40
849-I	¾ in.	2½ in.	1 in.	Nidar	6.00
849-K	1 in.	2½ in.	1 in.	Njoke	6.50

Woodruff System Milling Cutters



Made of High Speed steel, properly hardened and ground. Have straight shanks ½ inch in diameter. For milling Woodruff System Keyways.

Net Factory Prices

Cat. No.	Diam.	Width	Code Word	Price Each	Cat. No.	Diam.	Width	Code Word	Price Each
897-A	½ in.	¼ in.	Uabed	\$1.80	897-L	1½ in.	¼ in.	Ulaft	\$4.00
897-B	½ in.	¼ in.	Uboas	1.80	897-M	1½ in.	¼ in.	Umine	4.00
897-C	½ in.	¼ in.	Ucedx	2.10	897-N	1½ in.	¼ in.	Uneda	4.50
897-D	¾ in.	¼ in.	Udwin	2.50	897-O	1½ in.	¼ in.	Uopre	4.50
897-E	¾ in.	¼ in.	Ueyos	2.50	897-P	1½ in.	¼ in.	Uplat	4.50
897-F	¾ in.	¼ in.	Ufent	2.75	897-Q	1½ in.	¼ in.	Uqizn	5.00
897-G	¾ in.	¼ in.	Ugers	2.75	897-R	1½ in.	¼ in.	Urozz	5.00
897-H	1 in.	¼ in.	Uhomi	3.60	897-S	1½ in.	¼ in.	Usiab	5.00
897-I	1 in.	¼ in.	Uitca	3.60	897-T	1½ in.	¼ in.	Utopa	5.30
897-J	1 in.	¼ in.	Ujbis	3.60	897-U	1½ in.	¼ in.	Uvils	5.30
897-K	1½ in.	¼ in.	Ukase	4.00	897-V	1½ in.	¼ in.	Uwasp	5.30



Side Milling Cutters

Made of High Speed steel, properly hardened and ground ready for use. Will cut on face and either side. All cutters have 1-inch hole and standard keyway.

Net Factory Prices

Catalog No.	Width of Face	Diameter of Cutter	Diameter of Hole	Code Word	Price Each
850-A	¼ in.	3 in.	1 in.	Oates	\$ 5.40
850-B	¼ in.	3 in.	1 in.	Oband	6.25
850-C	¾ in.	3 in.	1 in.	Ocpis	6.65
850-D	¾ in.	3 in.	1 in.	Odote	7.15
850-E	¾ in.	3 in.	1 in.	Oehlt	7.65
850-F	¾ in.	3½ in.	1 in.	Ofare	10.65
850-G	¾ in.	4 in.	1 in.	Ogest	14.40
850-H	¾ in.	4 in.	1 in.	Ohugo	17.30
850-I	1 in.	5 in.	1 in.	Oieda	20.20

Straight Shank End Mills



Made of High Speed steel, properly hardened and ground. Right-Hand Cutters furnished unless otherwise specified.

Net Factory Prices

Cat. No.	Diam., In.	L'gth of Cut., In.	L'gth Over All, In.	Code Word	Price Each	Cat. No.	Diam., In.	L'gth of Cut., In.	L'gth Over All, In.	Code Word	Price Each
898-A	¼ in.	¾ in.	1¼ in.	Vabin	\$1.00	898-G	¾ in.	1¼ in.	1½ in.	Violo	\$1.30
898-B	¼ in.	¾ in.	1¼ in.	Vespe	1.00	898-H	¾ in.	1¼ in.	1½ in.	Viper	1.50
898-C	¼ in.	¾ in.	1¼ in.	Verti	1.00	898-I	¾ in.	1¼ in.	1½ in.	Vosge	1.90
898-D	¼ in.	¾ in.	1¼ in.	Vinte	1.00	898-J	¾ in.	1¼ in.	1½ in.	Voneg	2.40
898-E	¼ in.	¾ in.	1¼ in.	Vileg	1.15	898-K	¾ in.	1¼ in.	1½ in.	Vudin	2.65
						898-L	¾ in.	1¼ in.	1½ in.	Vusco	2.80

Spiral End Mills



Spiral End Mill

Made of High Speed steel, properly hardened and ground. Morse Standard Taper Shanks fit into head spindle of lathe. Right-Hand Mill furnished unless ordered otherwise.

Net Factory Prices of Spiral End Mills

Cat. No.	Diam. of Mill	Morse Taper	Code Word	Price Each	Cat. No.	Diam. of Mill	Morse Taper	Code Word	Price Each
868-A	⅜ in.	No. 2	Pablo	\$4.15	870-A	¾ in.	No. 3	Praiz	\$6.00
868-B	½ in.	No. 2	Peals	4.60	870-B	¾ in.	No. 3	Psalm	6.20
868-D	⅝ in.	No. 2	Phial	4.60	870-C	1 in.	No. 3	Pulet	6.20
868-E	¾ in.	No. 2	Pinke	4.60	870-D	1¼ in.	No. 3	Pwhat	7.10
868-F	¾ in.	No. 2	Plaid	5.30	870-E	1¼ in.	No. 3	Pysic	8.25
868-G	1 in.	No. 2	Ponds	5.75					

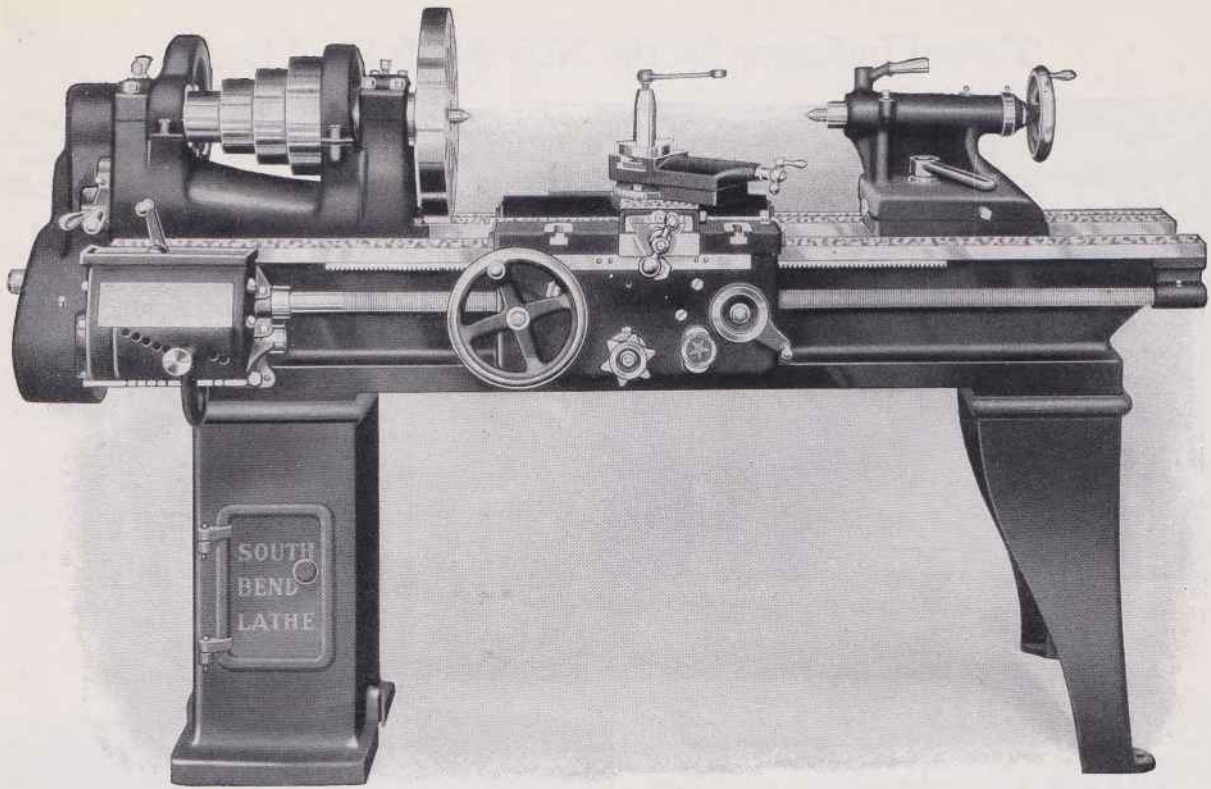

Cabinet Legs for South Bend Lathes

The illustration shows a 16-inch x 8-ft. South Bend Quick Change Gear Lathe fitted with a Cabinet Leg under the head end of the Lathe instead of the Regular Type Leg. Any size South Bend Lathe may be fitted with one or two Cabinet Legs. The Door on Cabinet Legs permits tools, attachments and wrenches being stored inside.

Prices of Cabinet Legs Instead of Regular Floor Legs

SIZE LATHE	9 in.	11 in.	13 in.	15 in.	16 in.	18 in.
Price of One Cabinet Leg	\$10.00	\$11.00	\$13.00	\$15.00	\$16.00	\$18.00
Code Words	Pagan	Peter	Phile	Plead	Polar	
Price of Two Cabinet Legs	\$20.00	\$22.00	\$26.00	\$30.00	\$32.00	\$36.00
Code Words	Padre	Pekoe	Pholk	Piles	Plank	Podge

Oil Pans for South Bend Lathes

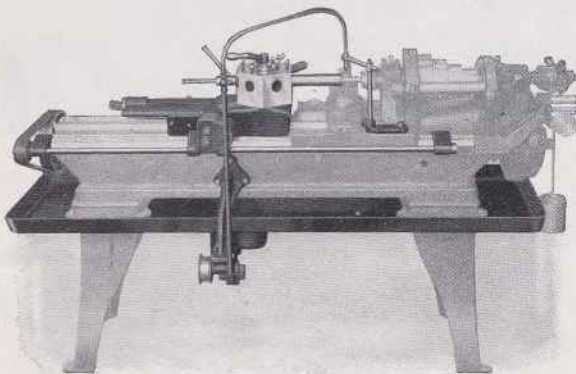

Shows Oil Pan, Pump, Reservoir, and Piping

Heavy One Piece Pressed Steel Oil Pan

The illustration above shows a lathe equipped with One Piece liquid tight Oil Pan, which can be furnished with any size South Bend Lathe. This Pan requires special construction of lathe legs.

Net Factory Prices Steel Oil Pan

Size of Lathe	Cat. No.	LENGTH OF BED							
		3-ft. Beds	3½-ft. Beds	4-ft. Beds	4½-ft. Beds	5-ft. Beds	6-ft. Beds	7-ft. Beds	8-ft. Beds
9 in.	282	\$14.00	\$15.00	\$16.00	\$17.00				
11 in.	284	16.00	17.00	18.00		\$20.00			
13 in.	286			20.00		22.00	\$25.00	\$28.00	\$31.00
15 in.	288					26.00	30.00	34.00	38.00
16 in.	292						33.00	37.00	41.00
Code Words		Oasis	Oback	Odium	Often	Ohern	Okres	Olean	Omens

Oil Pump, Reservoir, and Pipe Fittings

The method of attaching the Geared Oil Pump is shown in the illustration taken from the back of the Lathe. A large bracket attached to the Bed supports the Pump which delivers the liquid from the Reservoir to the work through flexible pipe line. The Pump is driven by a belt from an overhead countershaft.

Nozzle Travels with Carriage

The Nozzle of the Flexible Steel Pipe is attached to a bracket mounted on the Carriage of the Lathe, causing it to travel with the Lathe Tool. A valve located in the pipe line controls flow from nozzle.

Cast Iron Reservoir

The Reservoir bolts directly to the Steel Pan located usually at one end of the Lathe and is equipped with wire screen to strain fluid and prevent chips from entering. A plug in the bottom provides drainage.

What the Price Includes

The prices below include one Cast Iron Reservoir, Oil Pump with Supporting Bracket, Flexible Steel Pipe and Fittings, but not the Steel Oil Pan.

Net Factory Prices—Pump, Reservoir, and Fittings

Size of Lathe	Cat. No.	Code Word	Price Complete	Size of Lathe	Cat. No.	Code Word	Price Complete
9 in.	1051	Habit	\$35.00	15 in.	1054	Hopes	\$40.00
11 in.	1052	Hedge	35.00	16 in.	1055	Huber	45.00
13 in.	1053	Heron	40.00	18 in.	1056	Hymen	45.00

Thread Indicator for the New South Bend Lathes

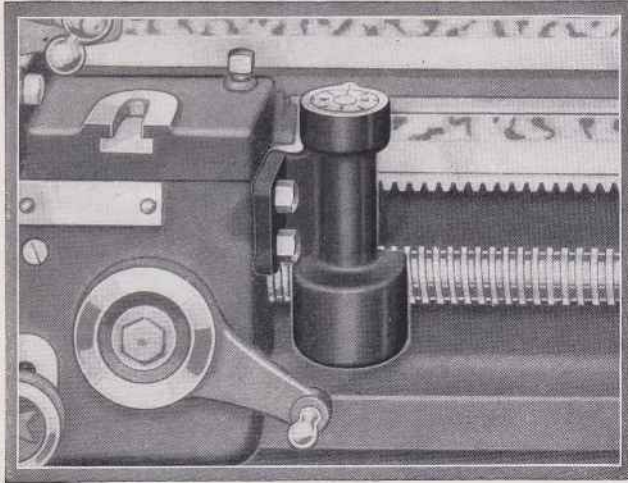

The New South Bend Thread Indicator eliminates the necessity of reversing the lathe to return the Carriage to the starting point to catch the thread at the beginning of each successive cut, thus affording a great saving of time.

Shows Proper Position for Engaging Half Nuts

The Face of the Dial is numbered and graduated to show the exact time to clamp the Half Nuts on the Lead Screw for the next cut. When cutting even threads, the Half Nuts are closed at any graduation on the Dial and for odd threads at any numbered line on the Dial. For pitches involving $\frac{1}{2}$ of a thread, such as $11\frac{1}{2}$ per inch, the Half Nuts are closed at any odd numbered graduation.

Net Factory Prices

Size of Lathe	Catalog No.	Code Word	Price Each	Size of Lathe	Catalog No.	Code Word	Price Each
9 in.	809	Abaft	\$ 8.00	16 in.	816	Aflot	\$12.00
11 in.	811	Aeres	8.00	18 in.	818	Agrol	12.00
13 in.	813	Advis	10.00	21 in.	821	Ahora	14.00
15 in.	815	Aesop	10.00	24 in.	824	Ajoin	14.00

Micrometer Carriage Stop for the New South Bend Lathes

The Micrometer Carriage Stop, shown in the illustration, is useful in manufacturing operations and in accurate facing on all kinds of work. It can be used as either a permanent or adjustable stop at any point along the lathe bed and on either side of the Carriage. Special means are provided for clamping the Micrometer Carriage Stop to the front "V" of the lathe bed so that it does not mar or injure the hand-scraped surface.

The Adjusting Sleeve

The Adjusting Sleeve is large in diameter and knurled on one end. The spindle is made of tool steel with hardened ends to prevent wear. A lock screw is provided so that the spindle can be set after final adjustments for a production job have been completed.

Net Factory Prices

Size of Lathe	Catalog No.	Code Word	Price Each	Size of Lathe	Catalog No.	Code Word	Price Each
9 in.	971	Calef	\$10.00	16 in.	975	Climb	\$10.00
11 in.	972	Ceded	10.00	18 in.	976	Coral	10.00
13 in.	973	Chain	10.00	21 in.	978	Cring	10.00
15 in.	974	Cigar	10.00	24 in.	979	Cupal	10.00

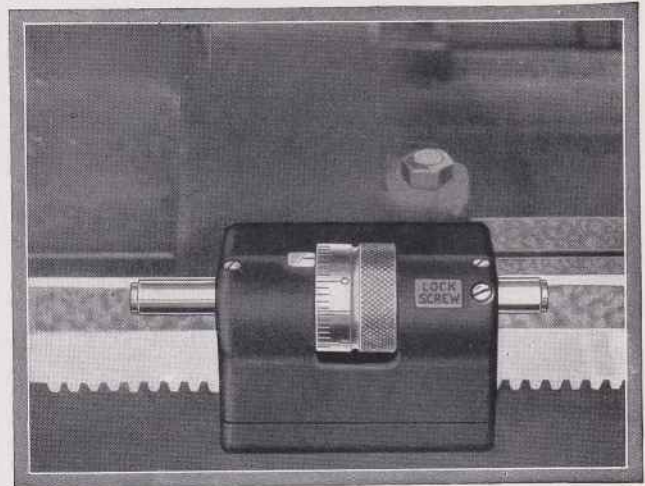

Relieving Attachment for the New South Bend Lathes

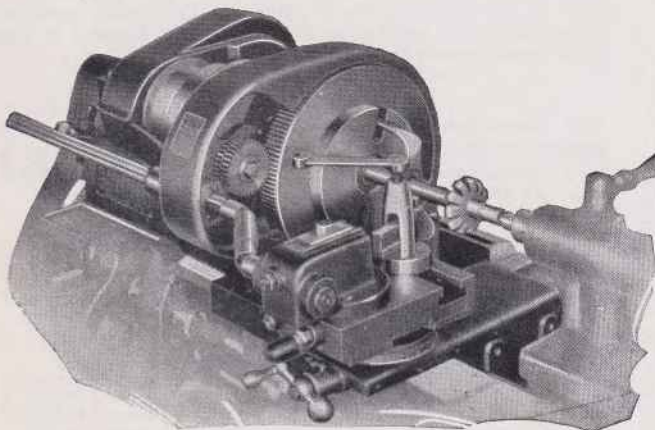

Relieving Attachment in Use on the Lathe for Relieving a Formed Cutter

This Attachment does every kind of relieving except spiral and has an unlimited range of angular work. It can be quickly changed from relieving to plain turning, thread cutting or vice versa. It has a graduated scale for amount of relief from 0 to $\frac{1}{8}$ inch.

Diameter and Class of Work Which Can Be Relieved

The diameter of work that can be relieved on a 15-inch Lathe is 6 inches—on a 16-inch Lathe, 6 inches—on an 18-inch Lathe, 7 inches—on a 21-inch Lathe, 7 inches. The class of work that can be relieved consists of: Milling cutters, reamers, taps, hobs, etc. It is also arranged for internal relieving of threading dies, etc. No machine work or special parts are required to fit the Relieving Attachment to South Bend Lathes.

Net Factory Prices

Size of Lathe	Cat. No.	Code Word	Price Each	Size of Lathe	Cat. No.	Code Word	Price Each
15 in.	953	David	\$285.00	18 in.	955	Diver	\$310.00
16 in.	954	Delta	285.00	21 in.	956	Dower	330.00

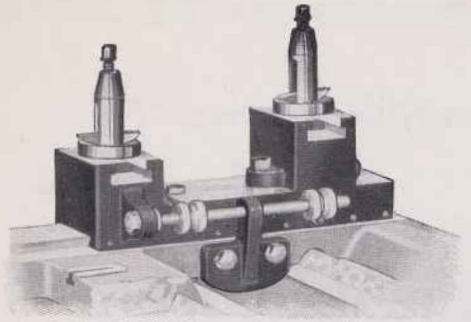

Double Tool Slide with Adjustable Stop

The Double Tool Slide illustrated above is controlled by the lathe cross feed screw. An adjustable stop regulates both front and back tools. Prices include front and back tool rest, adjustable stop and one tool post complete.

Net Factory Prices

Size of Lathe	Catalog No.	Code Word	Price Each
9 in.	981	Dakin	\$30.00
11 in.	982	Denis	30.00
13 in.	983	Divot	35.00
15 in.	984	Dobin	35.00
16 in.	985	Drips	40.00
18 in.	986	Ducts	40.00

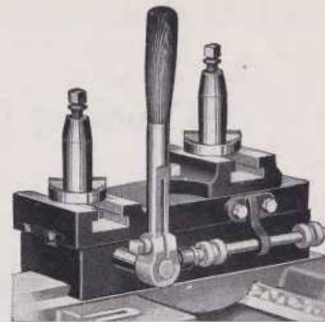

Double Tool Slide with Hand Lever

The Double Tool Slide is controlled by the Hand Lever which regulates the depth of the cut. An adjustable stop regulates both front and back tools.

Net Factory Prices

Size of Lathe	Catalog No.	Code Word	Price Each
9 in.	999-A	Daple	\$40.00
11 in.	999-B	Debit	40.00
13 in.	999-C	Diced	45.00
15 in.	999-D	Doles	45.00
16 in.	999-E	Drain	50.00
18 in.	999-F	Dufer	50.00

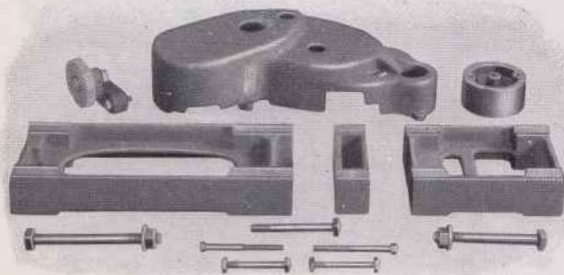

Raising Blocks for Straight and Gap Bed Lathes

Standard or Quick Change Gear Types

Raising Blocks can be supplied for Straight Bed and Gap Bed Lathes in the Quick Change Gear and Standard Change Gear types to increase the swing of the lathe for power turning feeds and cutting screw threads. The table below shows the increased swing of the various lathes, when equipped with Raising Blocks. The Silent Chain Motor Driven Lathes cannot be fitted with Raising Blocks.

PRICES OF RAISING BLOCKS

Straight Bed Lathes		Gap Bed Lathes		Quick Change Gear Lathes			Standard Change Gear Lathes		
Swing Over Bed	Swing Over Bed with Raising Blocks	Swing Over Gap	Swing Over Gap with Raising Blocks	Catalog No.	Code Word	Price	Catalog No.	Code Word	Price
9 1/4 in.	12 in.	1121	Cafer	\$ 30.00	1001	Cadie	\$ 25.00
11 1/4 in.	14 in.	16 in.	19 in.	1122	Ceare	36.00	1002	Cebro	30.00
13 1/4 in.	18 in.	18 in.	24 in.	1123	Charl	60.00	1003	Chink	50.00
15 1/4 in.	20 in.	22 in.	27 in.	1124	Cilov	72.00	1004	Citus	60.00
16 1/4 in.	22 in.	24 in.	30 in.	1125	Chiek	84.00	1005	Claro	70.00
18 1/4 in.	24 in.	26 in.	32 in.	1126	Coger	96.00	1006	Cobil	80.00
21 1/4 in.	27 in.	30 in.	36 in.	1127	Crops	120.00	1007	Crown	100.00
24 1/4 in.	30 in.	36 in.	42 in.	1128	Cueno	150.00	1008	Cudly	125.00

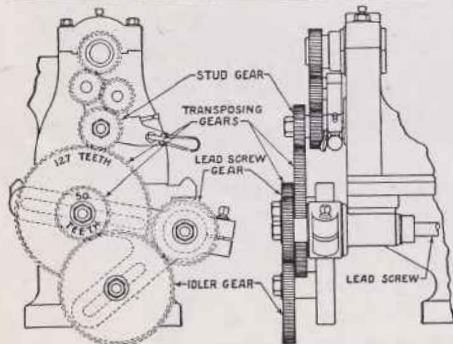

Transposing Gears for Cutting Metric Threads

On South Bend Standard and Quick Change Gear Lathes

To cut metric threads in addition to English threads on a Standard Change Gear or Quick Change Gear Lathe a set of transposing gears and a special bracket are required. Included in the set is a large gear having 127 teeth and a small gear having 50 teeth as shown in the illustration at left. The 127-tooth gear meshes with the stud gear and the 50-tooth gear connects with the idler, which in turn meshes with the lead screw gear. South Bend Standard Change Gear Lathes may be equipped with a Metric Lead Screw instead of an American Lead Screw, at extra cost, if desired.

Prices of Transposing Gears and Extra Gear Guard

QUICK CHANGE GEAR LATHES						STANDARD CHANGE GEAR LATHES						
Transposing Gears				Extra for Gear Guards		Transposing Gears			Extra for Gear Guards			
Size of Lathe	Catalog No.	Code Word	Price	Catalog No.	Code Word	Price	Catalog No.	Code Word	Price	Catalog No.	Code Word	Price
9 in.	1041	Favor	\$25.00	1141	Falks	\$10.00	1031	Fagot	\$25.00	1131	Fazer	\$10.00
11 in.	1042	Fezos	28.00	1142	Febro	12.00	1032	Feret	28.00	1132	Fewer	12.00
13 in.	1043	Figur	31.00	1143	Fibre	14.00	1033	Fixer	31.00	1133	Fimal	14.00
15 in.	1044	Flago	34.00	1144	Flims	16.00	1034	Flats	34.00	1134	Fleas	16.00
16 in.	1045	Foget	37.00	1145	Folaw	18.00	1035	Foxye	37.00	1135	Fowle	18.00
18 in.	1046	Frame	40.00	1146	Frih	20.00	1036	Frets	40.00	1136	Fruit	20.00
21 in.	1047	Furna	50.00	1147	Fuses	25.00	1037	Fueds	50.00	1137	Funey	25.00
24 in.	1048	Fylom	75.00	1148	Fymox	35.00	1038	Fyyps	75.00	1138	Fyter	35.00



Chucking Lathe with Turnstile Turret

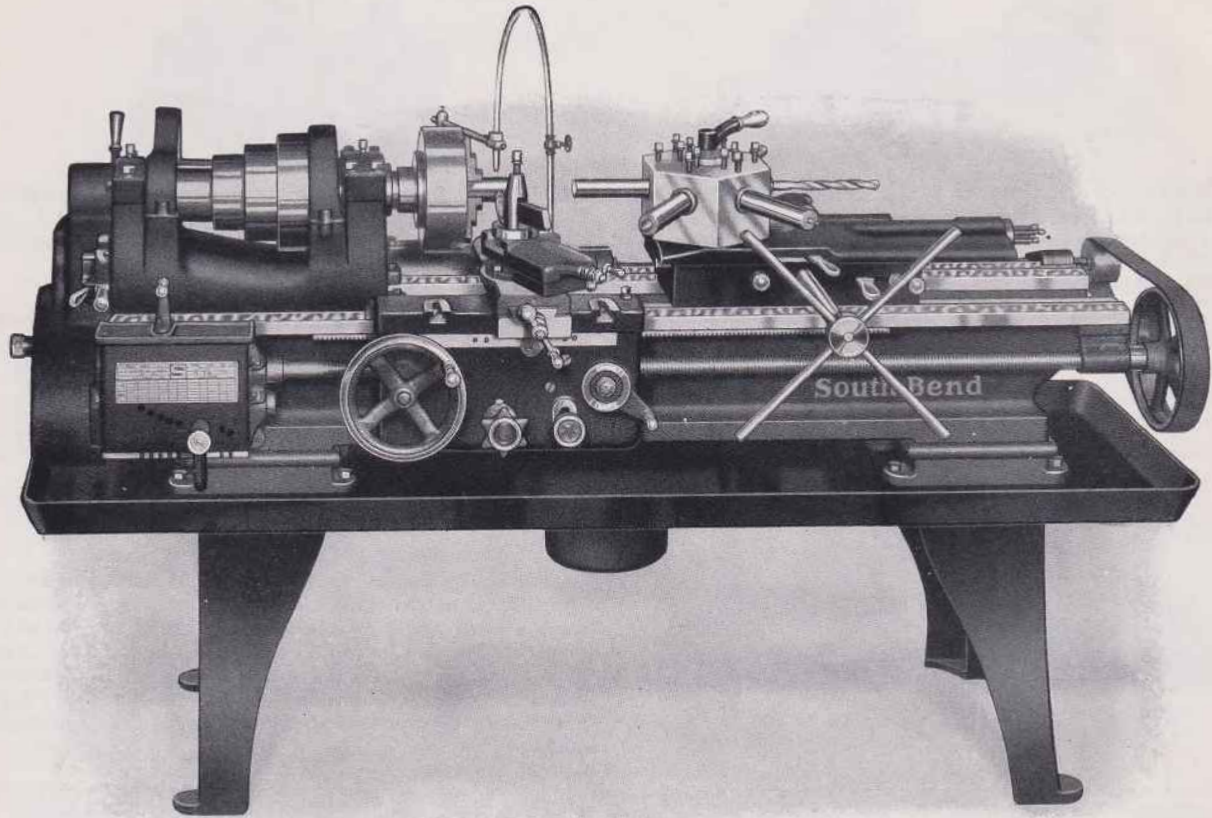

A South Bend Lathe Tooled for Chucking Work

The New South Bend Screw Cutting Lathe can be fitted with a variety of attachments and used to advantage for many manufacturing operations. A lathe equipped in this way serves the purpose of a Special Machine. When the job is finished, the attachments can be removed and the lathe used for general machine work.

Turnstile Bed Turrets

The cut at the right shows the Turnstile Bed Turret. This type of Turret can be furnished for all sizes of South Bend Lathes. The Turret Head is semi-automatic, and will revolve $\frac{1}{6}$ of a turn with each hand revolution of the Turnstile on the return stroke of the Slide. An Adjustable Stop is provided for each of the six faces of the Turret for regulating the depth of cut of each tool.

In ordering a Turnstile Turret for use on a South Bend Lathe, note the sizes of the holes indicated in the tabulation are the maximum diameter which can be bored into the face of the Turret Head and therefore the size wanted should be specified. The Turnstile Turret should be fitted to Lathe at the factory to insure perfect alignment with the Lathe Spindle. The Turret Slide may be fitted with Power Feed at extra cost. Prices quoted on application.

Draw-in Collet Chuck

The Hand Lever Draw-in Collet Chuck can be substituted for the 3-Jaw Universal Chuck and used to advantage for making small brass, bronze and steel parts on 11-inch or 13-inch South Bend Lathe equipped with a Hand Lever Bed Turret. Various types of Turrets that can be fitted to the South Bend Screw Cutting Lathe for manufacturing and special work are shown on page 49.

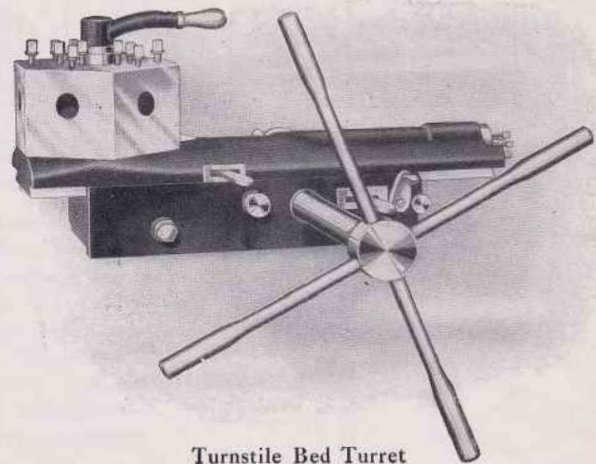

Turnstile Bed Turret

Net Factory Prices

Size of Lathe	Catalog No.	Size of Hole	Maximum Turret Feed	Weight Each	Code Words	*Price Each
11 in.	411	$\frac{7}{8}$ in.	6 in.	185 lbs.	Fairy	Not Made
13 in.	413	1 in.	9 in.	200 lbs.	Fellow	\$240.00
15 in.	415	1 in.	9 in.	225 lbs.	Fight	250.00
16 in.	416	1 in.	9 in.	225 lbs.	Flown	252.00
18 in.	418	$1\frac{1}{4}$ in.	12 in.	550 lbs.	Forts	300.00
21 in.	421	2 in.	15 in.	850 lbs.	Freud	375.00
24 in.	424	2 in.	15 in.	900 lbs.	Fudge	450.00

*An extra charge is made for fitting Turnstile Bed Turret to Lathe. Prices on application.



Lever Feed Bed Turrets and Tool Post Turrets

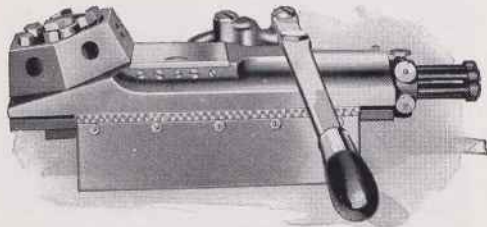

Semi-Automatic Bed Turret
Turret Revolves Automatically

The Semi-Automatic Bed Turret is intended only for 9-inch, 11-inch and 13-inch lathes. The Turret is hexagonal in shape and is automatically indexed one-sixth of a turn by the backward movement of the Hand Lever. Adjustable Stops are provided for each of the six faces of the Turret for regulating the depth of each tool and cannot be equipped with Automatic Power Feed. The feed of the Turret Slide is controlled by the Hand Lever. The Semi-Automatic Bed Turret should be fitted to the Lathe at the factory in order to insure perfect alignment with the Lathe Spindle. Prices and brief specifications appear in the tabulation below.

Net Factory Prices

Size of Lathe	Cat. No.	Turret Hole	Length of Turret Base	Max. Turret Feed	Weight Each	Code Words	*Price of Turret
9 in.	1509	5/8 in.	9 1/4 in.	4 1/4 in.	40 lbs.	Jaber	\$175.00
11 in.	1511	5/8 in.	9 1/2 in.	4 1/4 in.	60 lbs.	Jenks	185.00
13 in.	1513	5/8 in.	9 3/4 in.	4 1/4 in.	75 lbs.	Jilts	195.00

*An extra charge is made for fitting Semi-Automatic Bed Turret to Lathe. Prices on application.

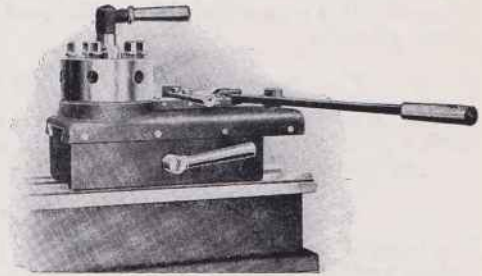

Hand Feed Bed Turret
Turret Revolves by Hand

The Hand Feed Bed Turret is low in price because it is not equipped with an Automatic Indexing Device or Adjustable Stops for regulating the depth of each tool. To place in operation, the clamping Lever at the top of the Turret is released and the Hand Feed Lever drawn back as shown in the illustration.

The Turret Head must be revolved by hand and each tool locked in position for operation. The feed of the Turret Slide is controlled by the Lever at the right. The Hand Feed Bed Turret is designed for use on the 11-inch and 13-inch lathes only, and must be fitted to Lathe at factory to provide perfect alignment with Lathe Spindle.

Net Factory Prices

Size of Lathe	Cat. No.	Turret Diameter	Diameter Hole	Length of Base	Length of Feed	Weight Each	Code Words	*Price of Turret
11 in.	1522	5 in.	3/4 in.	10 in.	4 1/2 in.	75 lbs.	Johns	\$ 90.00
13 in.	1526	5 1/2 in.	7/8 in.	12 in.	5 1/2 in.	85 lbs.	Junip	100.00

*An extra charge is made for fitting Hand Feed Bed Turret to Lathe. Prices on application.

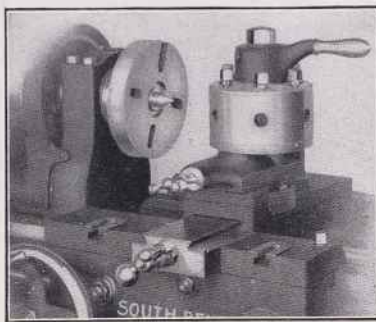

Round Tool Post Turret—Style E

The illustration shows the application of Tool Post Turret, Style E, held in the Compound Rest of the lathe. The Turret must be revolved one-sixth of a turn by hand after each tool has been in action. The Turret holes are about two inches deep and are left one-eighth inch under-size in diameter so they can be bored out to the sizes required on the lathe in order to insure perfect alignment with the lathe spindle. This Turret can be placed on or taken off the Lathe as easily and quickly as an ordinary Tool Post.

Net Factory Prices

Size of Lathe	Cat. No.	Code Words	*Price of Turret	Size of Lathe	Cat. No.	Code Words	*Price of Turret
9 in.	9-E	Zabet	\$65.00	16 in.	16-E	Zilky	\$90.00
11 in.	11-E	Zasto	65.00	18 in.	18-E	Zorbo	90.00
13 in.	13-E	Zerve	75.00	21 in.	21-E	Zouve	90.00
15 in.	15-E	Ziger	90.00	24 in.	24-E	Zupke	90.00

*An extra charge is made for fitting Round Tool Post Turret to Lathe. Prices on application.

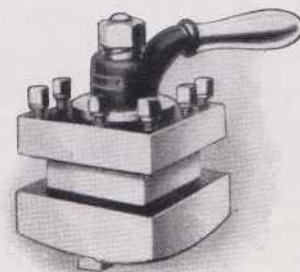

Four Way Tool Post Turret—Style O

The Four Way Tool Post Turret illustrated above is similar in construction to the Style E Tool Post Turret, except that it is bolted direct to the Compound Rest base and is designed so that standard lathe tool holders may be used. The lever at the top is used to release the indexing mechanism so that the desired tool can be swung into position. Either Forged Steel Lathe Tools or Patent Tool Holders of the sizes indicated below can be used with this Turret.

Net Factory Prices

Size of Lathe	Cat. No.	Size of Turret	Maximum Size of Tool	Weight of Turret	Code Words	*Price of Turret
13 in.	1538	5 in. Square	1 3/4 in. x 1/2 in.	85 lbs.	Yacht	\$100.00
15 in.	1539	5 in. Square	1 3/4 in. x 1/2 in.	90 lbs.	Yanks	100.00
16 in.	1540	6 in. Square	1 3/8 in. x 5/8 in.	95 lbs.	Yelks	125.00
18 in.	1541	6 in. Square	1 3/8 in. x 5/8 in.	100 lbs.	Yodel	125.00

*An extra charge is made for fitting Four Way Tool Post Turret to Lathe. Prices on application.



No. 10 Belt Drive Grinder

The No. 10 Belt Drive Grinder equips the lathe for doing a wide variety of work that would otherwise require a special grinding machine. It is a powerful Grinder designed for heavy duty precision grinding.

Construction of the No. 10 Grinder

Grinder frame is heavily constructed to resist vibration and clamps directly to Compound Rest which permits swiveling to any angle for grinding bevels and tapers.

What the Price Includes

The price of the No. 10 Belt Drive Grinder includes the Grinder Frame, one Emery Wheel, Bolt and Clamp for attaching to lathe.

Drum Countershaft

The Drum Countershaft is not included in the price of the grinder but is extra. Countershaft has Tight and Loose Pulley, Belt Shifter, Wick Oiling Bearings and Drum Pulley 12-in. diameter x 12-in. long. Longer Drum at extra cost.

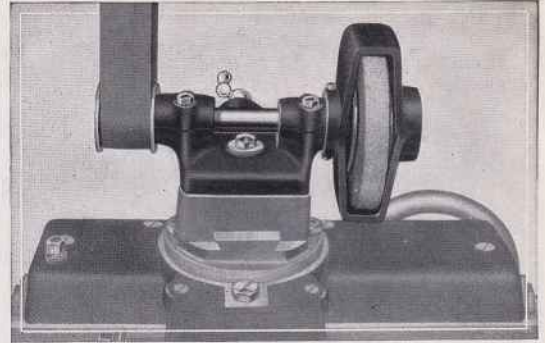

No. 10 Belt Drive Grinder

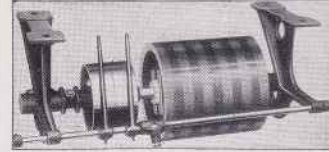

Drum Countershaft

Net Factory Prices of the No. 10 Belt Drive Grinder and Drum Countershaft

Size of Lathe	Grinding Wheels		Width of Belt	No. 10 Grinder and Emery Wheel			Drum Countershaft			Extra Wheels		
	Dia.	Width		Cat. No.	Code Word	Price	Cat. No.	Code Word	Price	Cat. No.	Code Word	Price
9 in.	4 in.	1 1/2 in.	1 in.	10-I	Yaxin	\$17.50	11-A	Yiqfe	\$35.00	21-A	Yqinl	\$1.70
11 in.	4 in.	1 1/2 in.	1 in.	10-J	Ybzor	17.50	11-B	Yipgf	35.00	21-B	Yrhom	1.70
13 in.	6 in.	3/4 in.	1 1/2 in.	10-K	Yewpn	20.00	11-C	Ykohg	35.00	21-C	Ysgpn	3.20
15 in.	6 in.	3/4 in.	1 1/2 in.	10-L	Ydval	20.00	11-D	Ylnih	35.00	21-D	Ytfqo	3.20
16 in.	6 in.	3/4 in.	1 1/2 in.	10-M	Yeuba	25.00	11-E	Ymlji	35.00	21-E	Yuerp	3.50
18 in.	6 in.	3/4 in.	1 1/2 in.	10-N	Yfteb	25.00	11-F	Ynnkj	35.00	21-F	Yydsq	3.50
21 in.	6 in.	3/4 in.	1 1/2 in.	10-O	Ygsde	25.00	11-G	Yokla	35.00	21-G	Ywetr	3.50
24 in.	6 in.	3/4 in.	1 1/2 in.	10-P	Yhred	25.00	11-H	Ypink	35.00	21-H	Yxdus	3.50

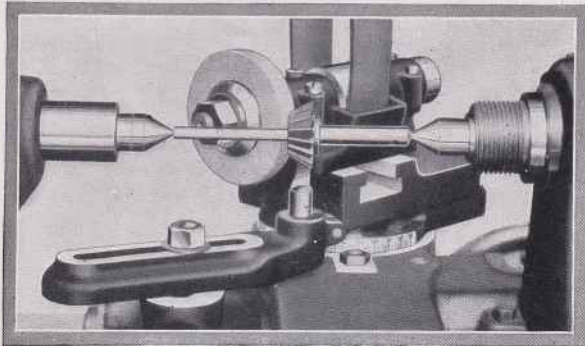

Grinding a Bevel Reamer in Lathe

The illustration shows a bevel reamer being sharpened by a grinding attachment on the lathe. Bevel reamers of any kind, right or left hand, including valve reamers, may be sharpened in the same manner.

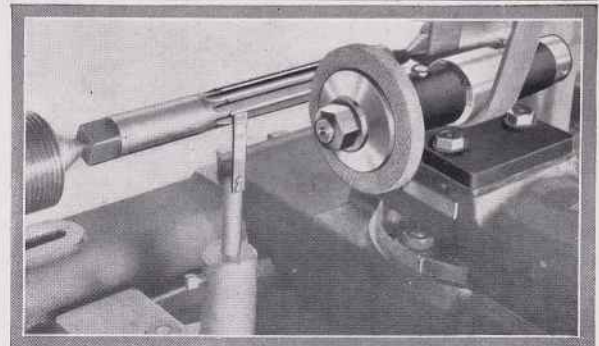

Grinding a Straight Reamer in Lathe

The illustration shows a hand reamer being sharpened between centers on the lathe with the use of the grinding attachment. Spiral reamers, right or left hand, can be ground in the same manner.

Adjustable Holding Fixture



Truing a Grinder Wheel

The No. 19 Holding Fixture will hold the industrial diamond for truing wheels, and it will also hold the cutter stop used when grinding cutters.

The Adjustable Holding Fixture clamps directly to the bed of the lathe, so that the carriage has free movement both when truing the grinding wheel and sharpening reamers and cutters.

A grinding wheel should be trued up frequently so that the cutting surface will be clean and run true.

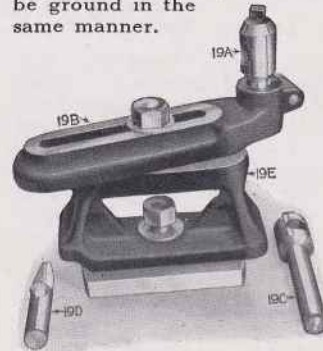

Net Factory Prices of Holding Fixture

Catalog No.	Code Word	Price each
19-A	Quartz	\$1.50
19-B	Quest	2.50
19-C	Quick	2.00
19-D	Quirt	1.50
19-E	Quota	2.50

No. 19 Adjustable Holding Fixture complete, weight 10 lbs. Code Word Quenc. Price, each\$8.00

Industrial Diamond Dresser



No. 18 Industrial Diamond, Special Metal Mount 1/3 Carat, Weight 1/4 lb., Net Factory Price each\$8.00 Code word Quaft.



No. 15 Electric Grinder for South Bend Lathes

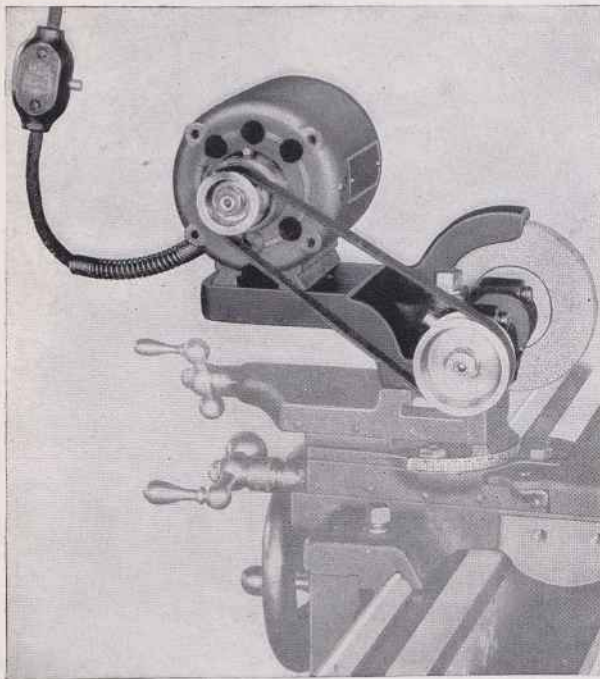

No. 15 Electric Grinder Mounted on Compound Rest of the Lathe

The No. 15 Electric Grinder can be used (or supplied) on any size of South Bend Lathe from 9-in. to 24-in. swing.

Practical for a Wide Variety of Work

This Electric Grinder is practical for grinding straight, taper or spiral reamers, milling cutters, taps, dies, valves, pistons, steel bushings, and hardened shafts, etc. If considerable stock is to be removed, use the turning tool of the Lathe to reduce the work to within a few thousandths of the finished size. Two or three cuts with the No. 15 Grinder will then produce a smooth accurate surface.

Operates from Electric Light Socket

The No. 15 Electric Grinder operates from an electric light socket. No special installation of electrical service is necessary. Specify electric current when ordering— if DIRECT current give voltage, if ALTERNATING current, give voltage, phase and cycle. The prices below include the No. 15 Electric Grinder as illustrated, with one Grinding Wheel and Clamp for mounting to Compound Rest.

Net Factory Prices

Catalog Number	Size of Lathe	Size Wheel	Outside Diameter Will Grind	Size Motor	Code Word	Price Each
15-I	9 in.	4 in. x 3/8 in.	4 3/4 in.	1/8 H.P.	Caret	\$65.00
15-J	11 in.	4 in. x 3/8 in.	7 1/2 in.	1/8 H.P.	Celts	65.00
15-K	13 in.	5 in. x 1/2 in.	9 in.	1/4 H.P.	Chums	75.00
15-L	15 in.	5 in. x 1/2 in.	10 1/2 in.	1/4 H.P.	Cinch	75.00
15-M	16 in.	5 in. x 1/2 in.	11 in.	1/4 H.P.	Clove	75.00
15-N	18 in.	5 in. x 1/2 in.	12 1/2 in.	1/4 H.P.	Coals	75.00
15-O	21 in.	5 in. x 1/2 in.	14 1/2 in.	1/4 H.P.	Crete	75.00
15-P	24 in.	5 in. x 1/2 in.	17 1/2 in.	1/4 H.P.	Cured	75.00

Internal Grinding Attachment for No. 15 Grinder

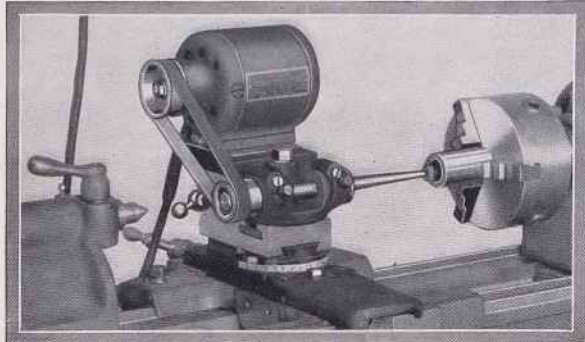

Grinding a Hardened Bushing with Internal Attachment



The Internal Grinding Attachment is used for the grinding of hardened bushings, holes in milling cutters, etc. This necessitates a very small wheel which should be operated at high speed. The correct grinding speed for internal grinding is obtained by placing the large pulley on the motor shaft and the small pulley on grinding spindle, as illustrated.

What the Price Includes

The price includes one 3 1/2-in. Extension Spindle threaded to fit the No. 15 Electric Grinder Spindle and four 3/4-in. x 1/4-in. grinding wheels. Will grind any hole over 1 in. in diameter and up to 3 1/2 in. deep.

No. 15W Internal Grinding Spindle with 4 Grinding Wheels, 3/4 in. x 1/4 in. Code word, Cruel. Net Factory Price each. \$15.00

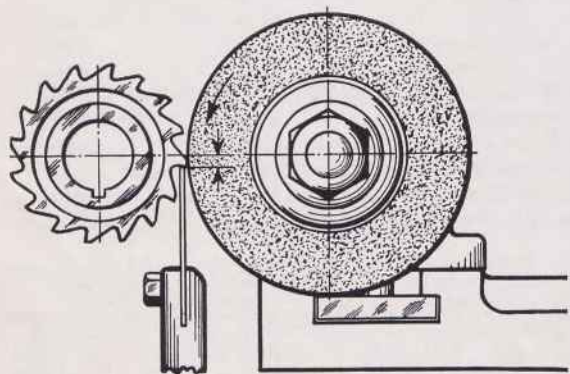

Grinding Clearance on a Milling Cutter

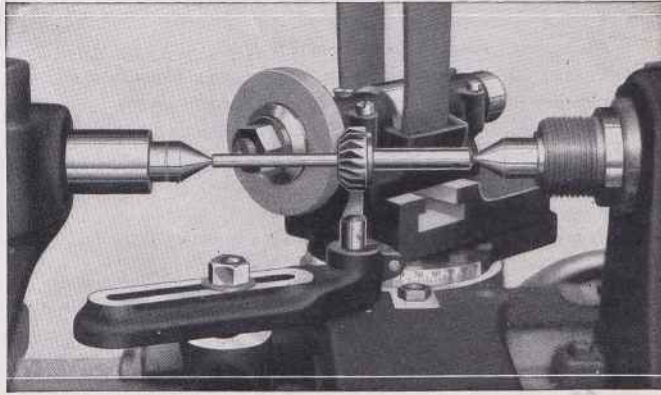

Sharpening a Valve Seat Reamer in the Lathe

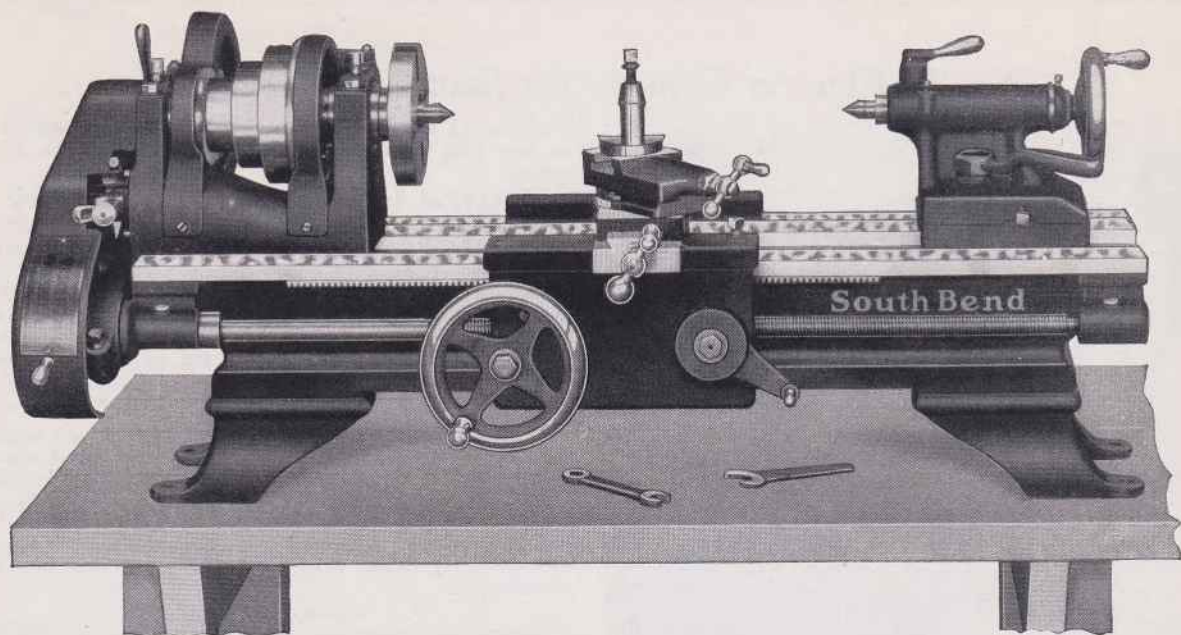

No. 22—9" x 3' New Model South Bend Junior Back Geared Screw Cutting Precision Lathe (Bench Type)

The New Model No. 22—9-inch Junior South Bend Screw Cutting Lathe is practical for general work in the machine shop, and for fine precision tool and instrument work. It is built of the same parts, has the same headstock, tailstock and bed as our 9-inch Standard and Quick Change Gear Lathe which we have been manufacturing for more than twenty-one years.

Power Feed Carriage. The carriage has power feed obtained by clamping the split nuts on the lead screw. This power feed can be adjusted from fine to coarse by the change gears included in the equipment of the lathe.

Cutting Screw Threads. The following standard threads, right or left, including 1 1/2 pipe thread, can be cut: 4, 5, 6, 7, 8, 9, 10, 11, 11 1/2, 12, 13, 14, 16, 18, 20, 22, 24, 26, 28, 30, 32, 36, 40. By compounding the gears many other threads may be cut.

The Hard Maple Bench is not included in the price of Bench Lathes but can be furnished at extra cost. For prices and descriptions of Bench see page 57.

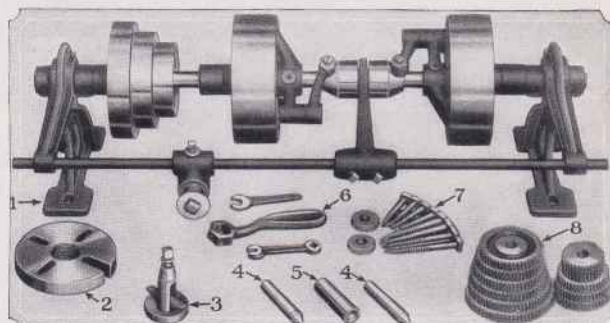

Equipment Illustrated Above Is Included in the Price of the Lathe. The Regular Equipment included with each 9-inch New Model Junior Bench Lathe consists of: Double friction countershaft, face plate, tool post complete, two lathe centers, spindle sleeve, wrenches, lag screws and washers and change gears as illustrated above.

Features and Specifications of the No. 22—9-inch Junior New Model Lathe Countershaft Drive. Bench and Floor Leg Types

Back geared head stock gives six spindle speeds.
Cone pulley balanced for operating at high speeds.
Hollow spindle, made of special carbon steel.
Spring latch reverse for feeds and threads.
Phosphor bronze spindle bearings.
Patent oil cups protect spindle bearings from dust.
Graduated compound rest swivels to any angle.
Tailstock is arranged for set-over for taper turning.
Carriage locks to lathe bed for accurate facing.
Micrometer collar on cross feed screw.
Micrometer collar on compound rest screw.
Precision lead screw for cutting accurate threads.

Swing over Bed 9 1/4 in.
Swing over Carriage 6 3/8 in.
Screw Thread Cutting Range 4 to 40 per in.
Head and Tail Spindle Centers . . . No. 2 Morse Taper
Size of Spindle Nose 1 1/2 in. diam., 8 Threads
Size of Hole through Spindle 3/4 in.
Width of Cone Pulley Belt 1 in.
Spindle Speeds 48, 78, 134, 248, 403, 714 R.P.M.
Countershaft speed 300 R.P.M.
Maximum Draw-in Collet Chuck Capacity . . . 1/2 in.
Countershaft Friction Pulley Size . . . 6 7/8 in. x 2 3/8 in.
Angular Travel of Compound Rest Top 2 in.
Size of Lathe Tool Shank 1 1/8 in. x 1 1/8 in.

Net Factory Prices of 9-inch Junior New Model Bench Lathe, Including Overhead Countershaft and Equipment

Swing Over Bed	Length of Bed	Between Centers	Hole Thru Spindle	Weight Crated	With Plain Rest		With Compound Rest	
							Cat. No.	Code Word
9 1/4 in.	2 1/2 ft.	11 in.	3/4 in.	350 lbs.	Discontinued	22-XC	Bylow	\$150.00
9 1/4 in.	3 ft.	18 in.	3/4 in.	375 lbs.	Discontinued	22-YC	Bhorn	155.00
9 1/4 in.	3 1/2 ft.	23 in.	3/4 in.	400 lbs.	Discontinued	22-ZC	Bmatx	160.00
9 1/4 in.	4 ft.	29 in.	3/4 in.	425 lbs.	Discontinued	22-AC	Blear	165.00
9 1/4 in.	4 1/2 ft.	36 in.	3/4 in.	450 lbs.	Discontinued	22-RC	Broil	170.00

Reduced Prices Effective October 1st, 1927

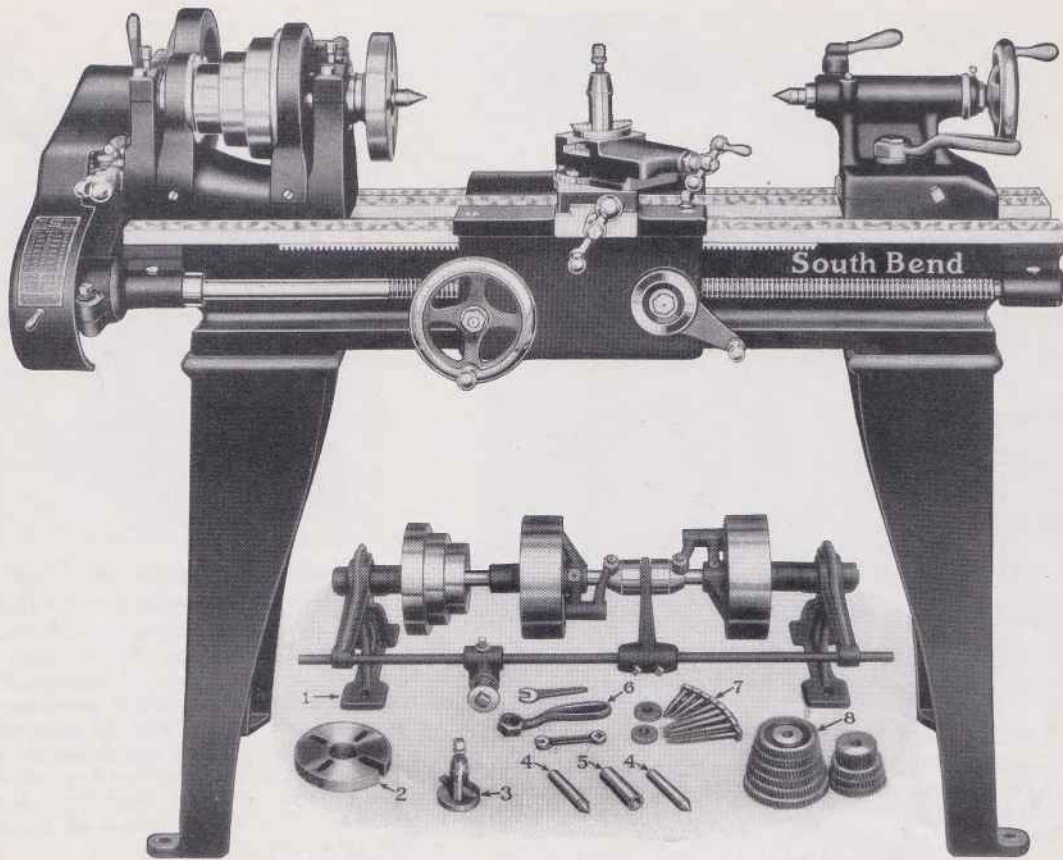

Regular Equipment, as Illustrated Under Lathe, Is Included in Price

No. 22—9-inch x 3-ft. New Model South Bend Junior

Back Geared Screw Cutting Precision Lathe (Floor Leg Type)

All Junior Lathes may be equipped with Floor Legs instead of Bench Legs. These legs are made of cast iron and are fastened to the lathe by steel cap screws. Both the bottom of the bed of the lathe and the top of the legs are machined to insure accuracy. Bench Legs and Floor Legs are interchangeable on all 9-inch Junior Lathes.

The Floor Legs make a good substantial support for the lathe with overhead countershaft drive or the Silent Chain Motor Drive. Features and Specifications of the 9-inch Junior Lathe with floor legs are the same as those for the Bench Lathe as listed on page 52 opposite.

Precision and Accuracy. Each of the No. 22—9-inch Junior Lathes undergoes 44 accuracy tests during the process of manufacture. In addition, 15 inspection tests are made on the various parts of this Lathe.

Cutting Screw Threads. The following standard threads, right or left, including 1 1/2 pipe thread, can be cut: 4, 5, 6, 7, 8, 9, 10, 11, 1 1/2, 12, 13, 14, 16, 18, 20, 22, 24, 26, 28, 30, 32, 36, 40. By compounding the gears many other threads may be cut.

Power Feed Carriage. The carriage has power feed obtained by clamping the split nuts on the lead screw. This power feed can be adjusted from fine to coarse by the change gears included in the equipment of the lathe. The Quick Acting Latch Reverse provides instant changing of the direction of power feed either to the right or left. A large turning gear and special compound gear provide fine feeds for finish turning.

Power. The power required to drive the No. 22—9-inch Junior Lathe is 1/4-horsepower, either by overhead countershaft or by motor drive. An ordinary electric lamp socket gives sufficient power to enable the Lathe to reduce a steel shaft from 2 3/4-inch to 2-inch in diameter in one cut. See page 54.

Attachments. Draw-in Collet Chuck, Milling Attachment, Taper Attachment and many other practical attachments have been developed for use on South Bend Lathes.

The Equipment included with each 9-inch New Model Junior Lathe consists of—Double Friction Countershaft, Face Plate, Tool Post complete, Two Lathe Centers, Spindle Sleeve, Wrenches, Lag Screws and Washers, and Change Gears as illustrated above under the lathe.

Prices on 9-inch Junior New Model Lathe (Floor Leg Type), Including Overhead Countershaft and Equipment

Swing Over Bed	Length of Bed	Distance Between Centers	Size of Hole in Spindle	Approximate Weight Cr	With Plain Rest		With Compound Rest	
					Cat. No.	Code Word	Price	Price
9 1/4 in.	2 1/2 ft.	11 in.	3/4 in.	415 lb.	Discontinued	22-XF	Byato	\$160.00
9 1/4 in.	3 ft.	18 in.	3/4 in.	440 lb.	Discontinued	22-YF	Bhunt	165.00
9 1/4 in.	3 1/2 ft.	23 in.	3/4 in.	465 lb.	Discontinued	22-ZF	Bmelo	170.00
9 1/4 in.	4 ft.	29 in.	3/4 in.	490 lb.	Discontinued	22-AF	Blunt	175.00
9 1/4 in.	4 1/2 ft.	36 in.	3/4 in.	515 lb.	Discontinued	22-RF	Bryan	180.00

Reduced Prices Effective October 1st, 1927

No. 722—9-inch Junior Self Contained Motor Drive Bench Lathe Unit

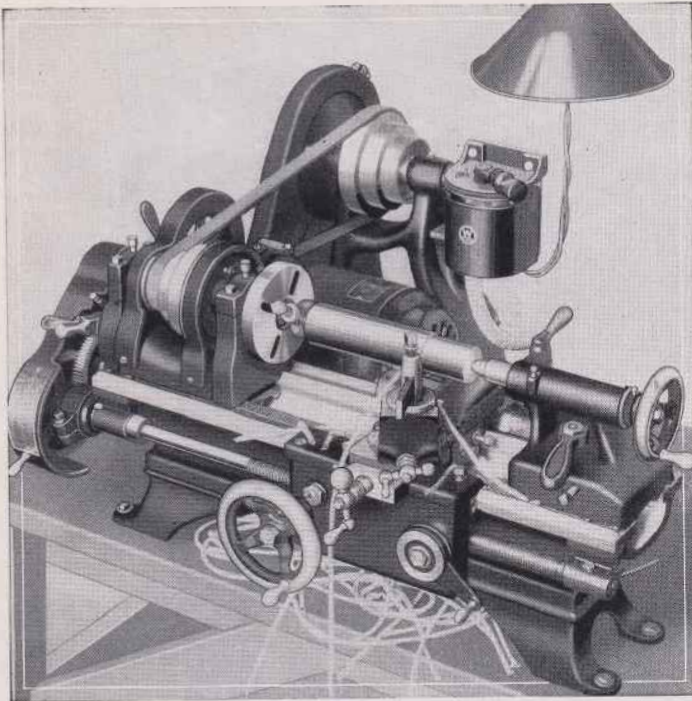

Front View of Self Contained Unit

The Self Contained Portable Motor Driven Junior Bench Lathe is practical for general work in the machine shop and for fine precision tool and instrument work. When this unit is mounted on a bench and connected to the current it is ready for operation.

Operates from Lamp Socket

A 1/4-horsepower reversing motor driven from an ordinary lamp socket gives sufficient power to operate the 9-inch Junior Bench Screw Cutting Lathe at maximum capacity.

The Reversing Switch (Drum Type)

The Reversing Switch (drum type) is conveniently located so that the operator can start, stop, or reverse the motor from an easy working position in front of the lathe. The switch has three positions: Left, for forward motion of lathe spindle, center for neutral, and right for reverse.

Specifications of Lathes

For specifications and descriptions of the 9-inch Junior Bench Lathes refer to page 52, as the only difference between the Self Contained Motor Driven Bench Lathe Unit and the Overhead Countershaft Driven Lathe is the form of drive.

Hard Maple Bench

The hard maple wooden bench illustrated above is not included in the price of the Self Contained Motor Driven Bench Lathe Unit but can be furnished at extra cost. For prices and descriptions of this bench see page 57.

Motor Specifications

When ordering a Self Contained Motor Driven Bench Lathe Unit be sure to specify the electric current. If alternating current, state exact voltage, phase, cycle and number of wires. If direct current, state exact voltage.



End View of Drive Unit

Part of Gear Removed to Show the Chain

The above illustration shows an end view of the Self Contained Unit Motor Drive, which is practical and efficient. It is placed directly behind the lathe on the bench in such a position that the cone pulleys will line up and the belts will track. The motor rests on a base and drives the countershaft cone through a chain and sprocket which gives a noiseless, efficient drive for a screw cutting lathe. The spindle cone of the lathe is driven by a leather belt.

Code Words

When ordering No. 722 Self Contained Unit Motor Driven Lathes by telegram or cablegram use code words listed below to indicate the Self Contained Motor Driven Lathe wanted. Use code words shown on page 28 to indicate motor specifications.

Electrical Equipment Included in Price

Electrical equipment included in the price of the Junior Self Contained Motor Drive Bench Lathe Unit consists of a 1/4-horsepower Reversing Motor 1200 R.P.M., Westinghouse, General Electric or equal make, Reversing Switch, Wiring between Motor and Switch, Flexible Metal Conduit and a Leather Belt.

Lathe Equipment Included in Price

Lathe equipment included in the price of the Junior Self Contained Motor Drive Bench Lathe Unit consists of bench lathe with Graduated Compound Rest, Unit Motor Drive, Face Plate, Tool Post Complete, Two Lathe Centers and Spindle Sleeve, Change Gears for Thread Cutting, Lag Screws and Washers and Wrenches. (Prices do not include Maple Bench, information of which will be found on page 57.)

Net Factory Prices 9-inch Junior Self Contained Motor Driven Bench Lathe Unit—Without Bench

Prices of Lathe with Compound Rest,* Reversing Motor, Reversing Switch

No. of Lathe	Swing Over Bed	Length of Bed	Size of Motor	Weight Crated	Code Word	With	With Single	With
						3 Phase 60 Cycle A. C. Motor	Phase 60 Cycle A. C. Motor	Direct Current Motor
722-XC	9 1/4 in.	2 1/2 ft.	1/4 H.P.	440 lbs.	Barbe	\$214.00	\$228.00	\$221.00
722-YC	9 1/4 in.	3 ft.	1/4 H.P.	470 lbs.	Bezor	219.00	233.00	226.00
722-ZC	9 1/4 in.	3 1/2 ft.	1/4 H.P.	500 lbs.	Boalt	224.00	238.00	231.00
722-AC	9 1/4 in.	4 ft.	1/4 H.P.	530 lbs.	Biase	229.00	243.00	236.00
722-RC	9 1/4 in.	4 1/2 ft.	1/4 H.P.	560 lbs.	Buble	234.00	248.00	241.00

*If Plain Rest is wanted instead of Compound Rest deduct \$10.00.

Reduced Prices Effective Oct. 1st, 1927

No. 322—9-inch Junior Silent Chain Motor Drive Lathe with Floor Legs

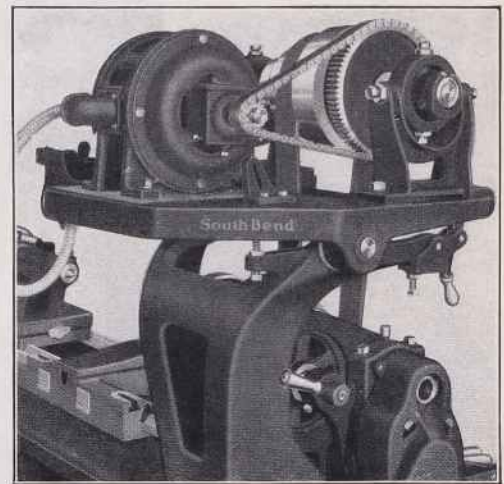
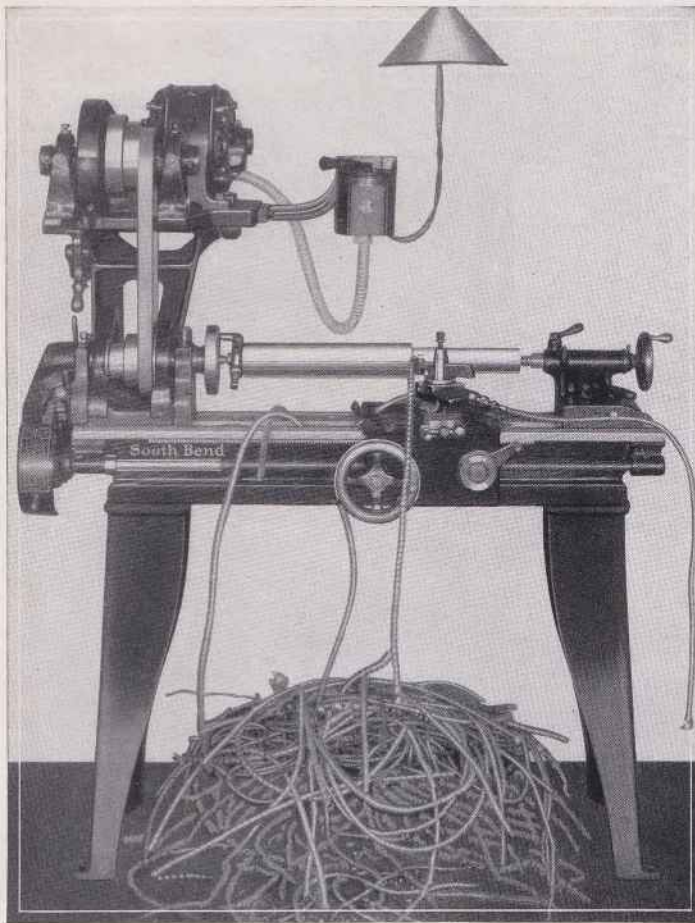

End View of Silent Chain Drive
Gear Guard Removed

In the above illustration, the chain guards are removed to show a close-up of the Silent Chain Drive connecting the motor to the upper cone shaft. This improved drive is efficient and practical, and will run for years with no attention other than occasional oiling.

The Reversing Switch

The Reversing Switch is conveniently located so that the operator can start, stop, and reverse the motor from an easy working position in front of the lathe. The switch has three positions: Left, for forward motion of lathe spindle, center for neutral, and right for reverse.

Code Words

When ordering No. 322 Silent Chain Motor Drive Lathes by telegram or cablegram use code words listed below to indicate the Silent Chain Motor Drive Lathe wanted. Use code words shown on page 28 to indicate motor specifications.

Electrical Equipment Included in Price

Electrical equipment included in the price of the 9-inch Junior Silent Chain Motor Drive Lathe consists of a 1/4-horsepower Reversing Motor, 1200 R.P.M., (Westinghouse, General Electric or equal make) Reversing Switch, Wiring between Motor and Switch, Flexible Metal Conduit, Wiring Diagram and a Leather Belt.

Lathe Equipment Included in Price

Lathe equipment included in the price of the 9-inch Junior Silent Chain Motor Drive Lathe consists of a Junior Lathe with Floor Legs and Graduated Compound Rest, Motor Drive Unit, Face Plate, Tool Post Complete, Two Lathe Centers and Spindle Sleeve, Change Gears for Thread Cutting, Lag Screws and Washers, and Wrenches.

9-inch Junior Silent Chain Motor Drive Lathe

The Silent Chain Motor Drive is a practical and efficient drive for the No. 22—9-inch Junior Lathe equipped with floor legs. The Silent Chain Drive which connects the motor with the upper cone is as positive as though it were direct geared. A small lever allows the table on which the motor sets to tilt and relieve the belt tension for easy shifting of the belt. An independent adjustment is provided for taking up the stretch of the belt.

Operates from Lamp Socket

A 1/4-horsepower reversing motor driven from an ordinary lamp socket gives sufficient power to operate the lathe at maximum capacity. When ordering a No. 322 Silent Chain Motor Drive Lathe, be sure to specify the electric current. If alternating current, state voltage, phase, cycle and number of wires. If direct current, state voltage. This information can be obtained from your electric light company.

Net Factory Prices of Silent Chain Motor Drive Lathe with Floor Legs

Prices of Lathe with Compound Rest,* Reversing Motor, Reversing Switch

Catalog No.	Swing Over Bed	Length of Bed	Weight, Crated	Code Word	With 3 Phase 60 Cycle A. C. Motor	With Single Phase 60 Cycle A. C. Motor	With Direct Current Motor
322-XC	9 1/4 in.	2 1/2 ft.	630 lbs.	Bazin	\$246.00	\$262.00	\$258.00
322-YC	9 1/4 in.	3 ft.	650 lbs.	Beuty	251.00	267.00	263.00
322-ZC	9 1/4 in.	3 1/2 ft.	670 lbs.	Bower	256.00	272.00	268.00
322-AC	9 1/4 in.	4 ft.	690 lbs.	Biolo	261.00	277.00	273.00
322-RC	9 1/4 in.	4 1/2 ft.	710 lbs.	Buton	266.00	282.00	278.00

*If Plain Rest is wanted instead of Compound Rest deduct \$10.00.

Reduced Prices Effective October 1st, 1927

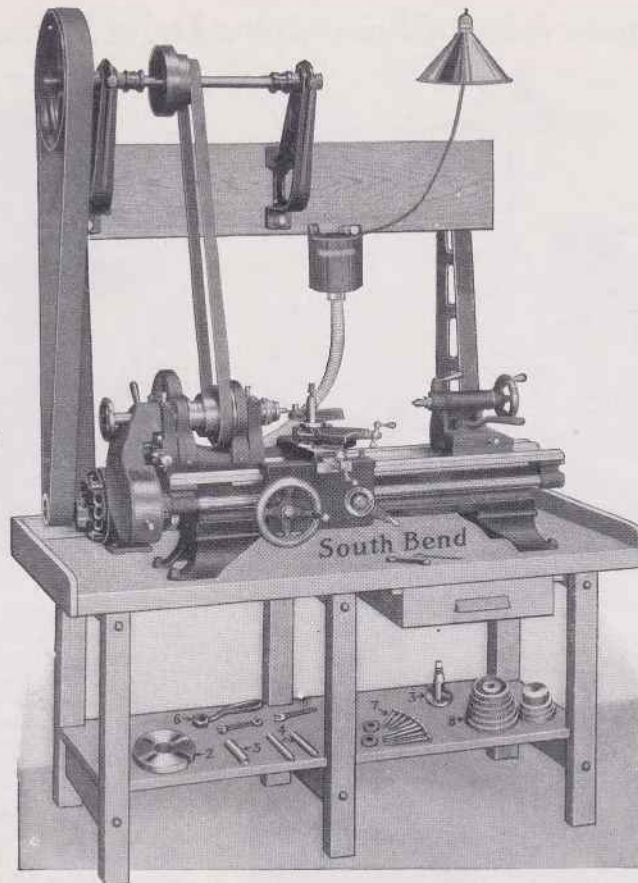

Motor rests on top of bench directly behind the lathe.

Equipment illustrated on shelf of bench is included in the price of the lathe.

No. 522—9-inch Junior Simplex Motor Drive Bench Lathe Unit

The illustration shows the lathe equipped with Draw-in Collet Chuck Attachment

The Simplex Motor Drive is a very practical method for driving a precision bench lathe used for general machine and tool work. The drive is noiseless and efficient in operation and makes a very complete and serviceable unit.

Operates from Lamp Socket

A 1/4-horsepower reversing motor driven from an ordinary lamp socket gives sufficient power to operate the lathe at maximum capacity.

When ordering a No. 522 Simplex Motor Drive Bench Lathe Unit, be sure to specify the electric current. If alternating current, state voltage, phase, cycle and number of wires. If direct current, state voltage.

The Reversing Switch

The Reversing Switch is conveniently located so that the operator can start, stop, or reverse the motor from an easy working position in front of the lathe. The switch has three positions: left, for forward motion of lathe spindle, center for neutral, and right for reverse.

Hard Maple Bench and Cast Iron Standards

The hard maple wooden bench, two cast iron standards, and cross board illustrated above are not included in the price of the Simplex Motor Driven Bench Lathe Unit but they can be furnished at extra cost. For prices and descriptions of these parts see page 57.

Net Factory Prices Simplex Motor Drive Bench Lathe Unit—Without Bench or Standards

Prices of Lathe with Compound Rest,* Reversing Motor, Reversing Switch

Catalog No. of Lathe	Swing Over Bed	Length of Bed	H.P. of Motor	Approximate Weight Crated	Code Word	With Three Phase 60 Cycle A. C. Motor	With Single Phase 60 Cycle A. C. Motor	With Direct Current Motor
522-XC	9 1/4 in.	2 1/2 ft.	1/4 H.P.	460 lbs.	Baxor	\$200.00	\$214.00	\$207.00
522-YC	9 1/4 in.	3 ft.	1/4 H.P.	475 lbs.	Behra	205.00	219.00	212.00
522-ZC	9 1/4 in.	3 1/2 ft.	1/4 H.P.	495 lbs.	Boflu	210.00	224.00	217.00
522-AC	9 1/4 in.	4 ft.	1/4 H.P.	515 lbs.	Bimlo	215.00	229.00	222.00
522-RC	9 1/4 in.	4 1/2 ft.	1/4 H.P.	535 lbs.	Bugel	220.00	234.00	227.00

*If Plain Rest is wanted instead of Compound Rest, deduct \$10.00.

Specifications of Lathes

For specifications and descriptions of the 9-inch Junior Bench Lathe refer to page 52, as the only difference between the Simplex Motor Driven Bench Lathe Unit and the Overhead Countershaft Driven Lathe is the form of drive.

Code Words

When ordering No. 522 Simplex Motor Driven Bench Lathes by telegram or cablegram use code words listed below to indicate the size Simplex Motor Driven Bench Lathe wanted. Use code words shown on page 28 to indicate motor specifications.

Electrical Equipment Included in Price

Electrical equipment included in the price of the Junior Simplex Motor Driven Lathe consists of a reversing motor, 1200 R.P.M., (Westinghouse, General Electric or equal make) reversing switch, wiring between motor and switch, flexible metal conduit, wiring diagram and two leather belts.

Lathe Equipment Included in Price

Lathe equipment included in the price of the Junior Simplex Motor Driven Lathe consists of: Junior bench lathe with graduated compound rest, Simplex drive countershaft, face plate, tool post complete, two lathe centers and spindle sleeve, change gears for thread cutting, lag screws and washers, and wrenches. (Prices do not include Maple Bench or Cast Iron Standards, information of which will be found on page 57.)

Hard Maple Benches For Bench Lathes



Hard Maple Bench with Drawer

This bench may be used with any type of 9", 11" and 13" bench lathe, overhead countershaft drive and motor drive patterns.

The bench illustrated above is made of fine quality hard maple with mortise and tenon construction throughout. It is finished in natural wood color with two coats of shellac. One drawer is provided for tools. Benches are shipped knocked down to save freight charges. Bolts are furnished for assembling bench.

If you wish to make your own bench, we will supply the blue prints of detail drawings showing complete specifications and dimensions of benches free of charge with the lathe.

Specifications and Prices of Benches

Length Bench Top	Width Bench Top	Thickness Bench Top	For Lathes with Bed Lengths of	Code Word	Catalog No.	Price
54"	28½"	1½"	2½'-3'-3½'	Cakes	128-X	\$35.50
72"	28½"	1½"	4'-4½'-5'	Cedar	128-A	36.50

Countershaft Standards for Simplex Motor Drive Bench Lathes



Maple Cross Board for Simplex Countershaft

The countershaft standards illustrated are used to support the cross board to which the Simplex countershaft is bolted. These standards are drilled for bolting to the bench and maple cross board. They are made of cast iron and painted a glossy black.



Cast Iron Standards

Maple Cross Board, only, Code Word "Churn." Price... \$ 1.00
Standards, per pair, drilled. Code Word "Cider." Price... 12.50

Extra Parts for 9-inch Junior Lathes



No. 125



No. 40



No. 130

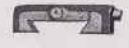

No. 67

No. 125 Center Rest, Code Word "Clift." Price.....\$10.00
No. 40 Large Face Plate, Code Word "Cryed." Price... 10.00
No. 130 Follower Rest, Code Word "Culve." Price..... 6.00
No. 67 Threading Stop, Code Word "Cobra." Price.... 2.50

No. 20—9-inch South Bend Special Back Geared Metal Turning Lathe

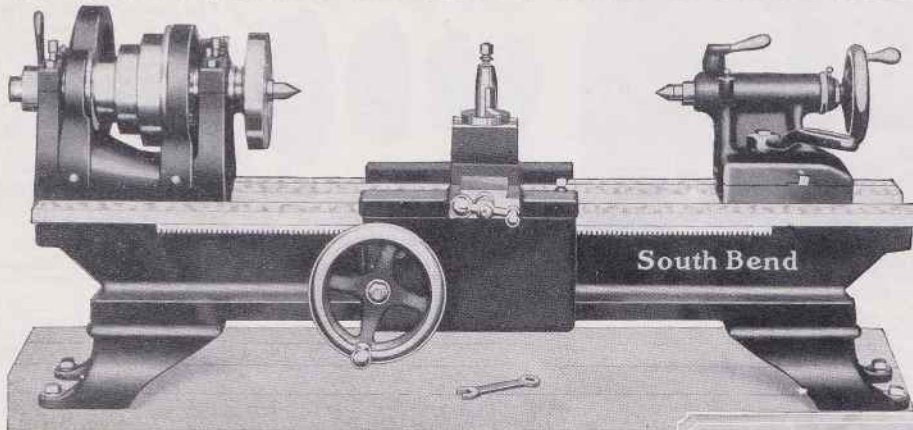

The No. 20 Special Back Geared Metal Turning Lathe is practical for machining all sorts of metals such as, wrought iron, steel, cast iron, brass, copper, bronze and aluminum. This is not a screw cutting lathe and is practical only for turning, boring, facing and other lathe work.

The Head Stock has three step cones for one-inch belt which with back gears gives six changes of spindle speeds. The spindle has ¾-inch hole its entire length which permits machining long bearings and rods through a Universal Chuck or through Draw-in Chuck. Carriage has hand feed. Tail Stock may be set over for taper turning. The phosphor bronze bearings are adjustable.

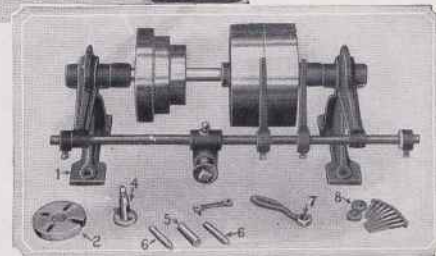

Equipment illustrated included in price of lathe.

Net Factory Prices 9-inch Special Bench Lathes Including Overhead Countershaft and Equipment

No. of Lathe	Swing Over Bed	Length of Bed	Between Centers	Hole Thru Spindle	Swing Over Carriage	Width of Cone Belt	Power Required	Weight Crated	With Plain Rest	
									Code Word	Price F.O.B. South Bend
20-XP	9¼ in.	2½ ft.	11 in.	¾ in.	6½ in.	1 in.	¼ H.P.	285 lbs.	Bagot	\$115.00
20-YP	9¼ in.	3 ft.	18 in.	¾ in.	6½ in.	1 in.	¼ H.P.	310 lbs.	Befog	120.00

If Long Legs are wanted instead of Short Legs, add \$10.00.

Piston Adapter with Rings

For Finishing Semi-Machined Pistons on the Lathe

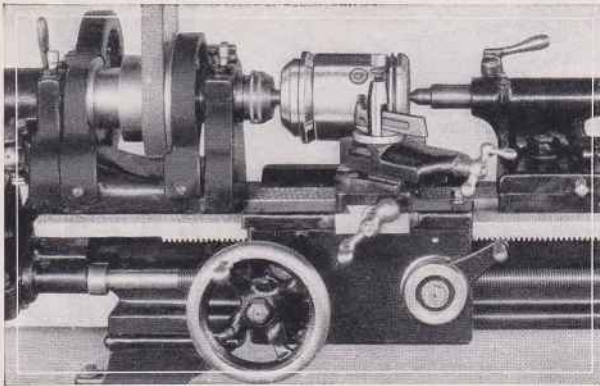

Machining a Piston to Finished Diameter in the 9-inch Lathe

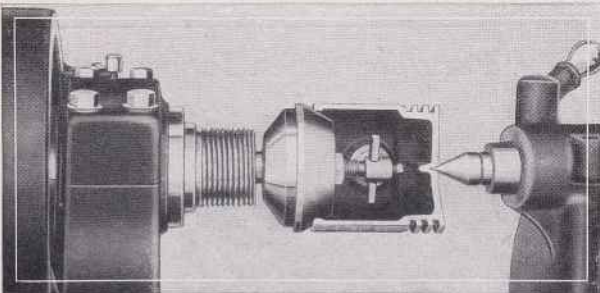

A Cross Section of a Piston Mounted in the Lathe on the Piston Adapter Ready for Machining

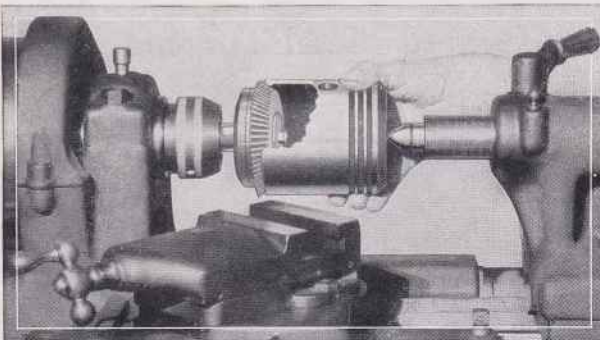

Reaming the Skirt of a Piston in the 9-inch Lathe

The bevel on the inside edge of the Piston skirt should be reamed to a true circle so that when the Piston is mounted in the adapter for machining it will center correctly and run true. All semi-machined Pistons warp out of shape while they are on the dealer's shelf and should be trued up as above before finish machining.

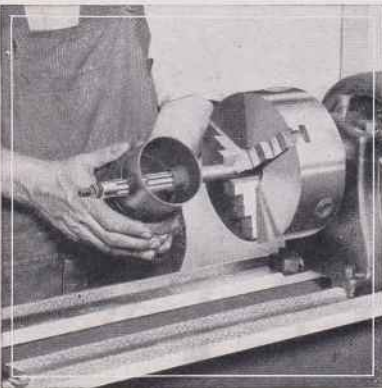

Reaming a Wrist Pin Hole in a Piston

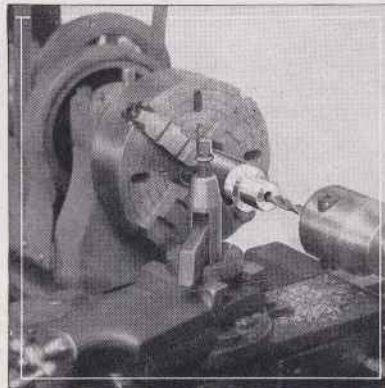

Boring a Bushing Held in Lathe Chuck

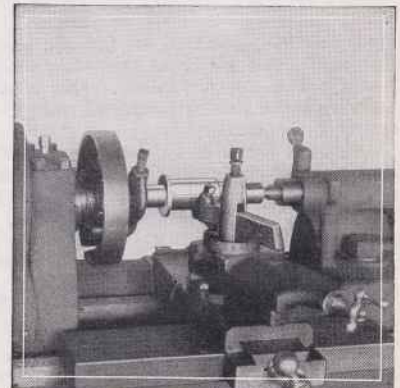

Turning Bronze Bushing on a Mandrel

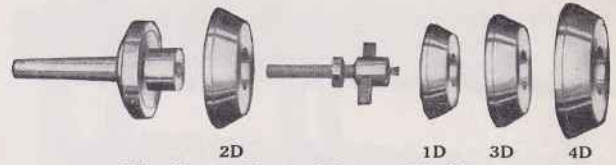

The No. 44 Piston Adapter with Rings

The above illustration shows the No. 44 Piston Adapter Shank, Cone Rings and Driving Dog. One end of the shank is tapered to fit the headstock spindle of the lathe. The other end is machined to receive the cone rings. The driving dog screws in the threaded hole in the end of the shank and may be adjusted to fit any size piston. One ring, No. 2D, the most popular size, is furnished with the Adapter. Extra rings may be supplied as shown below.

Specifications and Prices of Piston Adapters

Size Lathe	Morse Taper of Shank	Cat. No.	Code Word	Price Complete with shank, driving dog and one cone ring No. 2-D
9 in.	2	44-A	Hanov	\$12.00
11 in.	2	44-B	Hbiol	12.00
13 in.	3	44-C	Hclaw	13.00
15 in.	3	44-D	Hdixc	13.00
16 in.	3	44-E	Heeta	13.00
18 in.	3	44-F	Hfadx	13.00
21 in.	4	44-G	Hgony	14.00
24 in.	4	44-H	Hilao	14.00

Specifications and Prices of Cone Rings

Cone Ring Number	Will Hold Piston Outside Diameter	Code Word	Price, Extra Cone Rings
1D	2 $\frac{5}{8}$ to 3 $\frac{1}{4}$ in.	Hudso	\$2.50
2D	3 $\frac{1}{4}$ to 3 $\frac{3}{8}$ in.	Hwaki	2.50
3D	3 $\frac{3}{8}$ to 4 $\frac{1}{4}$ in.	Hyena	2.50
4D	4 $\frac{1}{2}$ to 5 $\frac{1}{4}$ in.	Hzage	2.50

Piston Skirt Reamers

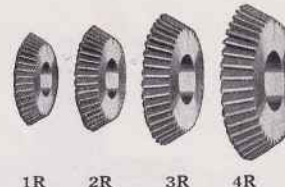

Piston Skirt Reamers

The Piston Reamers illustrated at the left are used on the No. 44 Piston Adapter Shank as the holes in the cone rings and the Reamers are the same size.

To true the Piston place the skirt on the Reamer as shown. Start the lathe, revolving the Reamer slowly, holding the Piston with the left hand. Take a light cut, feeding by the hand wheel of the tailstock with the right hand.

Specifications and Prices of Piston Skirt Reamers

Reamer Number	For Reaming Pistons Outside Diameter	Code Word	Price, Each Reamer
1R	2 $\frac{5}{8}$ to 3 $\frac{1}{4}$ in.	Hacke	\$ 7.50
2R	3 $\frac{1}{4}$ to 3 $\frac{3}{8}$ in.	Heine	9.00
3R	3 $\frac{3}{8}$ to 4 $\frac{1}{4}$ in.	Hiley	11.00
4R	4 $\frac{1}{2}$ to 5 $\frac{1}{4}$ in.	Holer	13.00

Electric Mica Undercutter

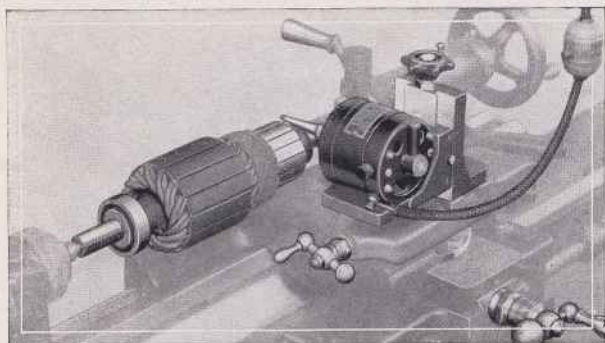

The No. 201 Electric Mica Undercutter is adjustable for various sizes of Commutators. It is made up of a special Motor mounted on a Sliding Bracket which fastens to the Tool Rest.

A set of 20 Disc Cutters, 1/4-inch in diameter, 4 each (.015 inch, .020 inch, .030 inch, .035 inch), is supplied with each Undercutting Tool.

Price includes motor, bracket, clamp and bolt for mounting on compound rest of lathe, and one set 20 disc cutters. When ordering specify whether 110-volt or 220-volt current motor is wanted.

Net Factory Prices of Electric Mica Undercutter

Size of Lathe	Electric Undercutter with One Set 20 Cutters			Extra Sets 20 Disc Cutters		
	Cat. No.	Code Word	Price Each	Cat. No.	Code Word	Price Per Set
9, 11, 13 in.	201-A	Ibvag	\$45.00	201-C	Imork	\$6.00
15, 16, 18 in.	201-B	Iduro	60.00	201-D	Insul	6.00

Shaper Type Mica Undercutter

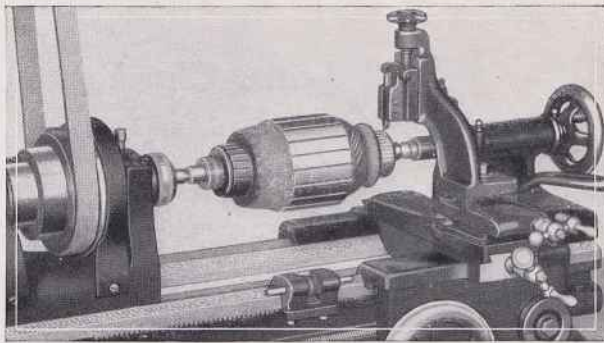

The No. 202 Shaper Type Mica Undercutter is a practical tool for relieving mica insulation between segments of commutators.

Vertical adjustment of the cutting tool is made through hand wheel at the top. The cutting stroke is made by turning the hand wheel on lathe apron. The high speed steel cutting tool, mounted in the clapper box, lifts up on the back stroke.

Price includes frame, one cutter bit, clamp and bolt for mounting on compound rest of lathe.

Net Factory Prices of Shaper Type Mica Undercutter

Size of Lathe	Shaper Undercutter with One Cutter Bit			Extra Cutter Bits		
	Cat. No.	Code Word	Price Each	Cat. No.	Code Word	Price Each
9, 11, 13 in.	202-A	Nasor	\$25.00	202-C	Nilos	\$0.25
15, 16, 18 in.	202-B	Neoph	35.00	202-D	Noble	.25

Machining Armatures on the 9-inch Lathe

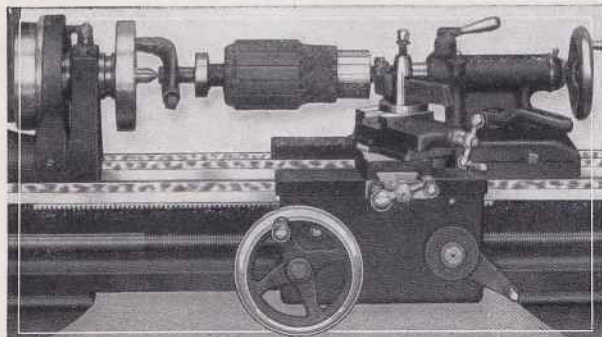

Truing an Armature Commutator Mounted Between Centers on a 9-inch Lathe



Testing a Bent Armature Shaft Between Centers on a 9-inch Lathe

Machining Valves on the 9-inch Lathe

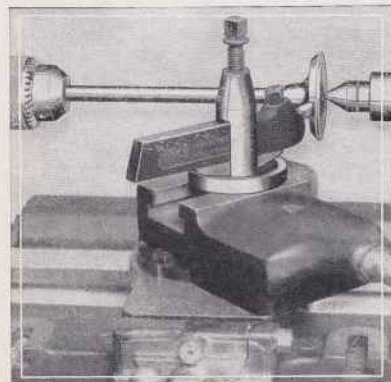

Refacing a Valve on a 9-inch Lathe

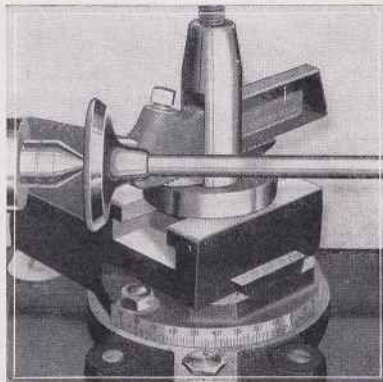

Compound Rest of Lathe Set at 45° Angle for Refacing Valves

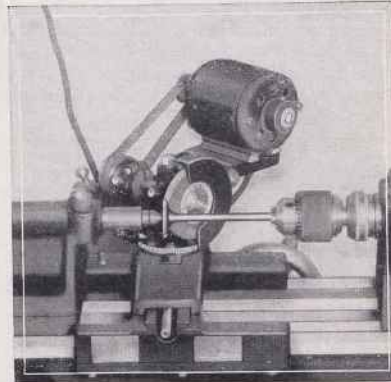

Refacing a Valve by Grinding on a 9-inch Lathe



Lathe Chucks for South Bend Lathes

Chuck Equipment for the New Lathe

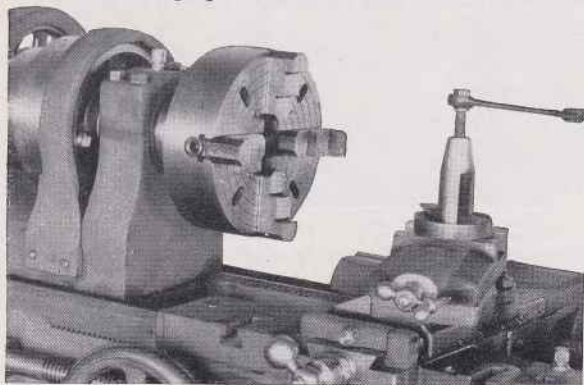

The Practical Type of Chuck for the Lathe

If the lathe is to have one chuck, it should be an Independent Lathe Chuck with 4 reversible jaws, as this type will hold both round stock and of irregular shape. If two chucks are to be fitted to the lathe, then a Universal Gearing Scroll Chuck should be used in addition to the Independent 4-jaw reversible type. A Universal Gearing Scroll Chuck is self-centering and therefore enables the operator to handle round and hexagonal stock without losing time in truing up the work.

Information on Ordering Lathe Chucks

In ordering a chuck for the lathe, there are two important points to consider. These are (1) SIZE OF CHUCK best suited to your work and (2) FITTING CHUCK to the Lathe. These points are fully explained on page 61.

Three-Jaw Universal Gearing Scroll Chucks With Two Sets of Jaws (Iron Body)

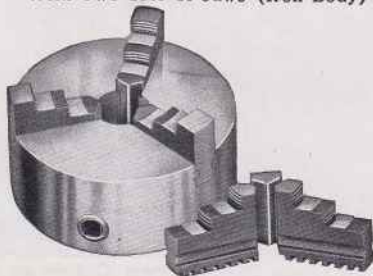

The 3-Jaw Universal Gearing Scroll Chuck is intended for holding round and hexagonal work. It is strictly a Universal Chuck, the jaws being moved simultaneously by the scroll threaded plate. This type of chuck is equipped with two sets of jaws—the No. 1 or Common Jaws for gripping work on the outside—the No. 2 or Reverse Jaws for holding work internally. Prices appearing below include wrench, two complete sets of Jaws and four cap screws for fastening chuck back to chuck.

Net Factory Prices

Cat. No.	Rated Size of Chuck	Will Hold About	Shipping Weight	Code Word	Price Chuck
2403	3 in.	3½ in.	3½ lbs.	Panel	\$ 22.00
2404	4 in.	4¼ in.	7½ lbs.	Paras	25.00
2405	5 in.	5 in.	11 lbs.	Parot	27.00
2406	6 in.	6½ in.	20 lbs.	Pasto	31.00
2407	7½ in.	7½ in.	32 lbs.	Patri	36.00
2409	9 in.	9 in.	45 lbs.	Pedal	43.00
2410	10½ in.	10½ in.	64 lbs.	Perag	48.00
2412	12 in.	12 in.	80 lbs.	Pensi	57.00
2415	15 in.	15 in.	143 lbs.	Perse	81.00
2418	18 in.	18 in.	180 lbs.	Perfu	105.00

NOTE—The above chuck prices do not include fitting chuck to lathe. For fitting prices see page 61.

Independent Lathe Chucks With Four Reversible Jaws (Iron Body)

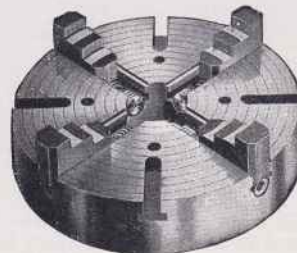

This Chuck has four independent solid jaws with individual screw adjustment. The face of Chuck is ground true to a straight edge and is accurately graduated in inches. The jaws are reversible by running out at the edge and turning end for end. All chucks are made with hardened steel bearings for the screws. T-slots are furnished only on chucks 12 inches and larger. Prices include wrench and four cap screws for fastening chuck back to chuck.

Net Factory Prices

Cat. No.	Rated Size of Chuck	Will Hold About	Shipping Weight	Code Word	Price Chuck
2104	4½ in.	6 in.	11 lbs.	Bawlo	\$21.00
2106	6 in.	7½ in.	21 lbs.	Beach	24.00
2108	8 in.	9½ in.	35 lbs.	Baacke	28.00
2109	9 in.	11½ in.	42 lbs.	Bairto	30.00
2110	10 in.	12½ in.	51 lbs.	Balda	36.00
2112	12 in.	14½ in.	90 lbs.	Baled	42.00
2114	14 in.	16½ in.	117 lbs.	Balks	46.00
2115	15 in.	18 in.	139 lbs.	Baimy	51.00
2116	16 in.	19 in.	147 lbs.	Bandu	54.00
2118	18 in.	21 in.	184 lbs.	Bankr	70.00

NOTE—The above chuck prices do not include fitting chuck to lathe. For fitting prices see page 61.

Combination Gearing Scroll Chucks With Four Reversible Jaws (Iron Body)

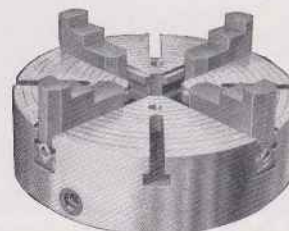

This improved Chuck is provided with independent, adjustable jaws which may be set as required for chucking round or irregular work, either in a concentric or in an eccentric position, and the Gearing Scroll Jaw operating mechanism may be used to grip the work. In tightening by the scroll mechanism universally, it is not necessary to apply the wrench successively in different positions around the Chuck, as any single application will give the full gripping power. Prices include wrench and four cap screws for fastening chuck back to chuck.

Net Factory Prices

Cat. No.	Rated Size of Chuck	Will Hold About	Shipping Weight	Code Word	Price Chuck
2504	4 in.	5½ in.	12 lbs.	Faile	\$ 45.00
2506	6 in.	7½ in.	22 lbs.	Fawno	57.00
2507	7½ in.	9¼ in.	39 lbs.	Fearu	69.00
2509	9 in.	11¼ in.	40 lbs.	Felta	75.00
2510	10½ in.	12½ in.	65 lbs.	Fendi	82.00
2512	12 in.	14½ in.	70 lbs.	Findr	94.00
2515	15 in.	17½ in.	101 lbs.	Fishb	120.00
2518	18 in.	21 in.	126 lbs.	Folds	160.00

NOTE—The above chuck prices do not include fitting chuck to lathe. For fitting prices see page 61.



Fitting a Lathe Chuck to the Lathe

The Screw Cutting Lathe generally requires one lathe chuck and sometimes two. If only one chuck is fitted, it should be the Four-Jaw Independent Chuck; if a second chuck is added, it should be a Three-Jaw Universal Geared Scroll Chuck.

In order to mount a lathe chuck on the lathe the chuck must be fitted with a semi-machined chuck back. Fitting a chuck to the lathe is a difficult job for the small

shop, especially if the mechanic lacks the special equipment of tools needed for the work.

In ordering your lathe we recommend that you order the chuck at the same time so that we can fit the chuck to the lathe here in our factory. We have special machinery and tools for doing this work which are operated by expert mechanics who have had years of experience in fitting chucks so that they will run true.

Semi-machined Chuck Back

The illustration shows a Semi-machined Cast Iron Chuck Back which has been bored, faced and threaded to fit the spindle nose of the Lathe. Sufficient stock is left on the diameter of the flange so that it can be machined to fit the recess on the back of the chuck.

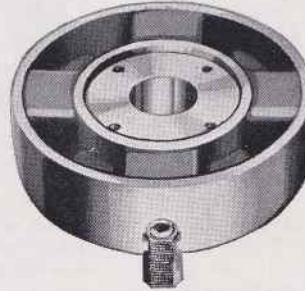

View of Rear Side of Chuck



Chuck Fitted to Lathe Complete

Net Factory Prices of Semi-machined Chuck Backs—Also Fitting Chuck to Chuck Back and Chuck Back to Lathe

Sizes of South Bend Lathes.....	9 in.	11 in.	13 in.	15 in.	16 in.	18 in.	21 in.	24 in.
Prices of Semi-machined Chuck Back.	\$4.00	\$4.25	\$4.50	\$4.75	\$5.00	\$ 5.50	\$ 7.00	\$ 8.00
Fitting Chuck to Semi-machined Chuck Back and to the Lathe.....	3.00	3.25	3.50	3.75	4.00	4.50	6.00	7.00
Total for fitting Chuck to Lathe....	7.00	7.50	8.00	8.50	9.00	10.00	13.00	15.00
Code Word	Ebert	Edwin	Ender	Eldon	Eliza	Elsie	Essen	Ethel

The Proper Sizes of Chucks for South Bend Lathes

To assist those who wish to select the proper sizes of chucks for South Bend Lathes, we list in the table below the sizes of Chucks best suited for each swing of lathe. These are the sizes we consider most practical for general work.

Table Showing Proper Sizes of the Different Types of Chucks for South Bend Lathes

SIZE OF LATHE	9 in.	11 in.	13 in.	15 in.	16 in.	18 in.	21 in.	24 in.
4-Jaw Independent Chuck.....	6 in.	6 in.	8 in.	9 in.	10 in.	12 in.	14 in.	15 in.
3-Jaw Universal Chuck.....	4 in.	5 in.	6 in.	7 1/2 in.	9 in.	10 1/2 in.	12 in.	15 in.
Combination Chuck	6 in.	6 in.	7 1/2 in.	10 1/2 in.	10 1/2 in.	12 in.	15 in.	18 in.
Drill Chuck, capacity.....	1/2 in.	1/2 in.	3/4 in.	3/4 in.	1 in.	1 in.	1 in.	1 in.

Drill Chucks for South Bend Lathes



Geared Three-Jaw Drill Chuck

The geared sleeve and key enable this drill chuck to be easily operated with one hand and to assure a powerful grip. Opening and closing the jaws is done by hand, the wrench being used only to tighten or release. Prices include pinion key. Chuck arbor is not included in these prices.

Net Factory Prices

Cat. No.	Capacity	Code Word	Price
1200	0 to 3/8 in.	Cleve	\$ 5.00
1201	0 to 1/2 in.	Wauko	8.00
1202	1/4 to 3/4 in.	Faloo	14.00
1203	3/8 to 1 in.	Frank	18.00



Finished Drill Chuck Arbor

The steel Drill Chuck Arbor is used for fitting the Drill Chuck to the lathe. The short taper fits into socket of Drill Chuck and the long taper fits into the taper of both the headstock spindle and the tailstock spindle of the lathe.

When ordering Drill Chuck Arbor only, state size and make of Drill Chuck, diameter and depth of arbor socket, and size of lathe on which the chuck is to be used.

Net Factory Prices

Size Lathe	Cat. No.	Code Word	Price Arbor
9 in.	709	Abner	\$2.50
11 in.	711	Acorn	2.50
13 in.	713	Adams	3.00
15 in.	715	Aford	3.00
16 in.	716	Agate	3.00
18 in.	718	Ajack	3.00
21 in.	721	Along	4.50
24 in.	724	April	4.50

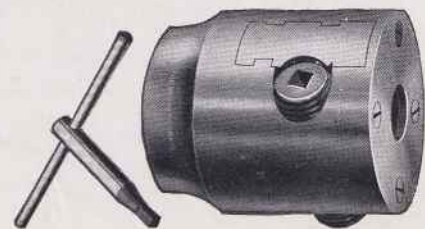

Two-Jaw Drill Chuck

A strong, simple chuck for straight shank drills, taps, reamers, etc. Jaws are tempered steel and operated by a heavy screw.

Net Factory Prices

Cat. No.	Capacity	Code Word	Price
1300	3/8 in.	Oblig	\$ 8.50
1301	1/2 in.	Objec	10.00
1302	3/4 in.	Octav	11.50
1303	1 in.	Optio	15.00



Patent Tool Holders for South Bend Lathes

Straight Shank Turning Tool



Drop Forged Steel

Prices include Wrench and one high speed Steel Cutting Bit.

Net Factory Prices

Size of Lathe, Inches	Catalog No.	Size of Shank, Inches	Size of Cutter, Inches	Code Word	Price Each
9	849-S	1 1/8 x 1 1/8	1/4 x 1/4	Azamm	\$2.40
11	851-S	3/8 x 3/8	1/4 x 1/4	Aybnm	2.55
13, 15	852-S	1/2 x 1 1/8	1/8 x 1/8	Axeol	3.00
16, 18	853-S	5/8 x 1 3/8	3/8 x 3/8	Awdpk	3.60
21, 24	854-S	3/4 x 1 5/8	1/2 x 1/2	Aveqj	4.85

Left-Hand Off-Set Turning Tool



Drop Forged Steel

Price includes Wrench and one high speed Steel Cutting Bit.

Net Factory Prices

Size of Lathe, Inches	Catalog No.	Size of Shank, Inches	Size of Cutter, Inches	Code Word	Price Each
9	849-L	1 1/8 x 1 1/8	1/4 x 1/4	Aufri	\$2.40
11	851-L	3/8 x 3/8	1/4 x 1/4	Atgsh	2.55
13, 15	852-L	1/2 x 1 1/8	1/8 x 1/8	Ashtg	3.00
16, 18	853-L	5/8 x 1 3/8	3/8 x 3/8	Ariuf	3.60
21, 24	854-L	3/4 x 1 5/8	1/2 x 1/2	Aqjve	4.85

Right-Hand Off-Set Turning Tool



Drop Forged Steel

Price includes Wrench and one high speed Steel Cutting Bit.

Net Factory Prices

Size of Lathe, Inches	Catalog No.	Size of Shank, Inches	Size of Cutter, Inches	Code Word	Price Each
9	849-R	1 1/8 x 1 1/8	1/4 x 1/4	Apkwd	\$2.40
11	851-R	3/8 x 3/8	1/4 x 1/4	Aolxc	2.55
13, 15	852-R	1/2 x 1 1/8	1/8 x 1/8	Anmyb	3.00
16, 18	853-R	5/8 x 1 3/8	3/8 x 3/8	Amnza	3.60
21, 24	854-R	3/4 x 1 5/8	1/2 x 1/2	Aloaz	4.85

Formed Threading Tool



Drop Forged Steel

Requires grinding on top only to sharpen. Price includes one Formed Cutter, V. U. S. S., or Whitworth Standard, U. S. S.'d furnished unless otherwise ordered.

Net Factory Prices

Size of Lathe, Inches	Size Holder, Inches	Extra Cutters			Tool Complete		
		Catalog No.	Code Word	Price Each	Catalog No.	Code Word	Price Each
9	5/8 x 3/4	860	Akpbj	\$2.40	865	Afrgt	\$3.75
11	3/4 x 7/8	861	Ajqex	2.40	866	Aeshs	3.75
13, 15	1/2 x 1 1/8	862	Airdw	2.85	867	Adtir	4.50
16, 18	5/8 x 1 3/8	863	Ahqev	3.75	868	Aecuq	5.75
21, 24	3/4 x 1 5/8	864	Agpfu	4.75	869	Abvqp	7.50

High Speed Steel Cutter Bits for Turning Tools

Ground to Shape

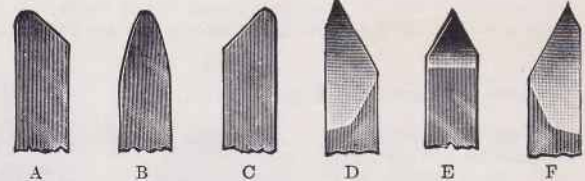

A Left Hand Turning Tool Adhlp
 B Round Nose Turning Tool Aeimq
 C Right Hand Turning Tool Afjnr
 D Left Hand Side Tool Agkos
 E Threading Tool Ahlpt
 F Right Hand Side Tool Aimqu

Code words above indicate shape of the cutting edge. Code words in table below indicate size of the cutter bit—use both codes when ordering.

The illustrations above show the cutting edge of six high speed steel hardened cutter bits, ground to shape, ready for use. This set of ground cutter bits covers the range of general lathe work, however, if other shapes of cutting edges are wanted the user may grind these bits as desired to suit the work that he has in hand. In using ground cutter bits it would be well for the operator to dress the cutting edge down with an oil stone. This increases the life of the cutting edge of the tool.

Net Factory Prices

Cat. No.	Size, Square Inches	Length, Inches	Approx. Wt. per Dozen, Pounds	Single Bits		Set of Six Bits	
				Code Word	Price Each	Code Word	Price Each
1309	3/8	1 1/2	1/4	Ajnrj	\$.25	Aoswa	\$1.50
1311	1/4	2 1/4	3/4	Akosw	.30	Aptxb	1.80
1313	1/8	2 1/2	1 1/4	Alptx	.45	Aquyc	2.70
1316	3/8	3	1 3/4	Amquy	.65	Arvzd	3.90
1321	7/8	3 1/2	2 3/4	Anrvz	1.00	Aswae	6.00

High Speed Steel Cutter Bits

Not Ground to Shape



The above illustration shows the hardened high speed steel cutter bit before the cutting edge is ground to shape. The operator can grind the cutter bits to shape to suit his work. These cutter bits are supplied in the various dimensions to fit the different size of tool holders for various size lathes.

These high speed steel cutter bits are of the finest quality high speed steel and will give excellent service.

Net Factory Prices

Catalog No.	Size, Square Inches	Length, Inches	Wt. per Dozen, Pounds	Code Word	Price Each
1509	3/8	1 1/2	1/4	Atxbf	\$.15
1511	1/4	2 1/4	3/4	Auyeg	.20
1513	1/8	2 1/2	1 1/4	Avzdh	.35
1516	3/8	3	1 3/4	Awaei	.55
1521	7/8	3 1/2	2 3/4	Axbfj	.90

Spring Threading Tool

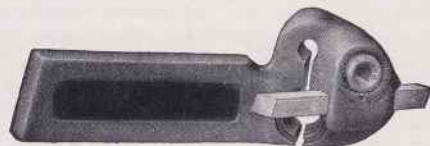

Drop Forged Steel

Price includes Holder with Headless Cam, Lock Nut, finished high speed Steel Cutter and Hardened Wrench.

Net Factory Prices

Size of Lathe, Inches	Size Holder, Inches	Extra Cutters			Tool Complete		
		Catalog No.	Code Word	Price Each	Cat. No.	Code Word	Price Each
11	3/8 x 7/8	870	Ayegk	\$.40	873	Aefjn	\$3.75
13, 15	1/2 x 1 1/8	871	Azdhi	.50	874	Adgko	4.50
16, 18	5/8 x 1 3/8	872	Abeim	.65	875	Aeilq	5.75



Patent Tool Holders for South Bend Lathes

Straight Cutting-Off Tool Drop Forged Steel



Price includes Wrench and one High Speed Steel Cutter Blade.

Net Factory Prices

Size of Lathe, Inches	Size of Shank, Inches	Size of Cutter, Inches	Extra Cutter Blades			Tool Complete		
			Cat. No.	Code Word	Price Each	Cat. No.	Code Word	Price Each
9	5/8 x 3/4	5/8 x 1/2	876-S	Absr	\$.55	881-S	Agone	\$2.60
11	3/4 x 7/8	3/4 x 5/8	877-S	Acard	.60	882-S	Ahern	2.75
13, 15	1/2 x 1 1/4	1/2 x 3/4	878-S	Adelt	.80	883-S	Ajame	3.25
16, 18	5/8 x 1 3/4	5/8 x 7/8	879-S	Aerop	1.15	884-S	Akilt	4.00
21, 24	3/4 x 1 5/8	3/4 x 1	880-S	Afail	2.00	885-S	Alips	5.50

Right-Hand Cutting-Off Tool Drop Forged Steel



Price includes Wrench and one High Speed Steel Cutter Blade. Left-Hand Cutting-off Tools can be furnished at same prices.

Net Factory Prices

Size of Lathe, Inches	Size of Shank, Inches	Size of Cutter, Inches	Extra Cutter Blades			Tool Complete		
			Cat. No.	Code Word	Price Each	Cat. No.	Code Word	Price Each
9	5/8 x 3/4	5/8 x 1/2	876-R	Cabag	\$.55	881-R	Cheld	\$2.60
11	3/4 x 7/8	3/4 x 5/8	877-R	Cbent	.60	882-R	Cnom	2.75
13, 15	1/2 x 1 1/4	1/2 x 3/4	878-R	Cdart	.80	883-R	Clain	3.25
16, 18	5/8 x 1 3/4	5/8 x 7/8	879-R	Cealn	1.15	884-R	Cmolt	4.00
21, 24	3/4 x 1 5/8	3/4 x 1	880-R	Cfond	2.00	885-R	Cnase	5.50

Knurling Tool Drop Forged Steel



Price includes Holder and one set of Knurls. Knurls can be furnished coarse, medium, and fine, in either Straight Line or Diamond pattern. Medium Diamond Knurls will be furnished unless otherwise specified.

Net Factory Prices

Size of Lathe, Inches	Size of Shank, Inches	Dimensions of Knurls, In.			Extra Knurls			Tool Complete		
		Dia.	Face	Hole	Cat. No.	Code Word	Price Each	Cat. No.	Code Word	Price Each
9	5/8 x 3/4	5/8	3/8	7/16	886	Dacos	\$.90	891	Dgelt	\$5.10
11	3/4 x 7/8	3/4	1/2	7/8	887	Dbord	.90	892	Dhapo	5.50
13, 15	1/2 x 1 1/4	3/4	1/2	1/2	888	Deram	1.00	893	Djoge	6.00
16, 18	5/8 x 1 3/4	3/4	1/2	1/2	889	Demon	1.00	894	Djoma	7.25
21, 24	3/4 x 1 5/8	3/4	1/2	1/2	890	Dfint	1.00	895	Dksep	7.25

Style "A" Boring Tool For Heavy Duty

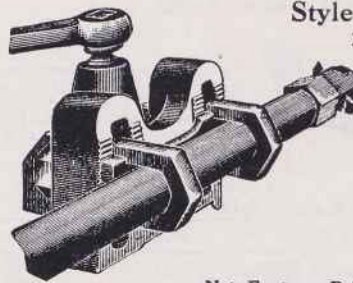

Fits regular tool post by removing tool post ring and wedge only.

Cutter bit is adjustable and may be set either straight or at a 45 degree angle.

Price includes Holder, Boring Bar, Wrench and one High Speed Steel Cutter Bit.

Net Factory Prices

Size of Lathe, Inches	Size of Shank, Inches	Size of Bar, Inches	Size of Cutter, Inches	Extra Cutter Bits			Tool Complete		
				Cat. No.	Code Word	Price Each	Cat. No.	Code Word	Price Each
13, 15	1/2 x 1 3/4	7/8 x 14	5/16	451	Faded	\$.30	426	Faber	\$ 6.50
16, 18	5/8 x 2	1 1/8 x 16	3/8	452	Fedar	.50	427	Feast	8.50
21, 24	3/4 x 2 1/4	1 1/4 x 18	7/16	453	Fieto	.75	428	Fized	10.25

Style "B" Boring Tool For Medium Work



Made of Drop Forged Steel. Cutting tool can be set either straight or at a 45 degree angle. Price includes Holder, Bar, one End Cap, two Cutters, and two Wrenches.

Net Factory Prices

Size of Lathe, Inches	Holder Size, Inches	Size of Square Cutter, Inches	Standard Bar Size, Inches	Extra Cutter Bits			Tool Complete		
				Cat. No.	Code Word	Price Each	Cat. No.	Code Word	Price Each
9	5/8 x 3/4	3/16	1/2	454	Hadie	\$.10	429	Habor	\$4.40
11	3/4 x 7/8	1/8	3/8	455	Hboya	.10	430	Hbaet	4.40
13, 15	1/2 x 1 1/4	3/16	3/4	456	Heino	.20	431	Hcoil	5.25
16, 18	5/8 x 1 3/4	1/8	1 1/8	457	Hdazt	.30	432	Hdeal	6.90
21, 24	3/4 x 1 5/8	1/8	1 3/8	458	Hezik	.50	433	Herth	9.80

Style "C" Boring Tool For Small Work

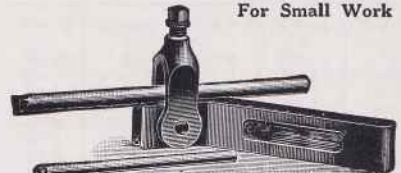

Made of Drop Forged Steel. Holder is reversible and can be used for right or left-hand work.

Price includes Holder, Wrench, two Boring Bars and one High Speed Cutter Bit.

Net Factory Prices

Size of Lathe, Inches	Size of Shank, Inches	Diameter of Bars Furnished, Inches	Size of Square Cutter, Inches	Extra Cutter Bits			Tool Complete		
				Cat. No.	Code Word	Price Each	Cat. No.	Code Word	Price Each
11	3/4 x 3/4	1/8 and 1/4	1/4	459	Ibolk	\$.20	434	Ibexo	\$3.75
13, 15	1/2 x 1	3/16 and 5/16	3/8	460	Ierem	.35	435	Ieole	4.75
16, 18	5/8 x 1 1/4	1/4 and 3/8	1/2	461	Idrat	.55	436	Idavy	6.10
21, 24	3/4 x 1 1/2	5/16 and 3/4	3/4	462	Ierio	.90	437	Ieloa	7.75

Hand Forged Lathe Tools—Carbon and High Speed Steel

Properly forged to shape, tempered and ground. Ready for use. If ordering less than one complete set, be sure to state both the tool number and set number.

Net Factory Prices

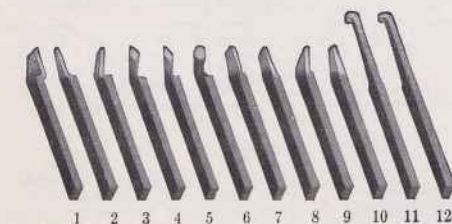

1. Left-Hand Side Tool
2. Right-Hand Side Tool
3. Right-Hand Bent Tool
4. Right-Hand Diamond Point
5. Left-Hand Diamond Point
6. Round Nose Tool
7. Cutting-Off Tool
8. Threading Tool
9. Bent Threading Tool
10. Roughing Tool
11. Boring Tool
12. Inside Threading Tool

Size of Lathe, Inches	Size of Shank, Inches	Carbon Steel				High Speed Steel			
		Cat. No.	Price Each	Set of 12		Cat. No.	Price Each	Set of 12	
				Code Word	Price			Code Word	Price
9	5/8 x 5/8	438-C	\$.60	Jaelo	\$ 7.00	438-HS	\$ 2.00	Jgher	\$ 20.00
11	3/4 x 3/4	439-C	.70	Jbaux	8.00	439-HS	2.80	Jhrix	32.00
13	1/2 x 1	440-C	1.20	Jcein	14.00	440-HS	4.20	Jipav	50.00
15	5/8 x 1	443-C	1.60	Jdolw	19.00	443-HS	5.85	Jkoop	70.00
16, 18	5/8 x 1 1/8	441-C	2.00	Jerov	23.00	441-HS	7.20	Jleap	85.00
21, 24	3/4 x 1 1/2	442-C	3.00	Jflat	35.00	442-HS	14.40	Jmixd	170.00



Lathe Dogs and Tools for South Bend Lathes

Standard Lathe Dogs

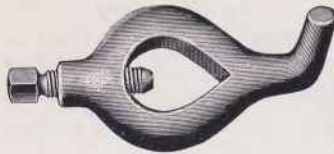

Furnished in either heavy malleable iron or special drop forged steel. Properly designed for strength and service. Price includes hardened tool steel set-screw.

Net Factory Prices

Capacity of Lathe Dog	MALLEABLE IRON			FORGED STEEL		
	Catalog No.	Code Word	Price Each	Catalog No.	Code Word	Price Each
3/8 in.	1-M	Xaced	\$.50	1-F	Xnoqp	\$1.00
1/2 in.	2-M	Xedfe	.60	2-F	Xoprq	1.10
3/4 in.	4-M	Xdegf	.70	3-F	Xpqr	1.20
1 in.	6-M	Xefhg	.80	4-F	Xqrts	1.40
1 1/4 in.	8-M	Xfigh	.90	5-F	Xrsut	1.70
1 1/2 in.	10-M	Xghij	1.05	6-F	Xstuv	2.00
1 3/4 in.	11-M	Xhikj	1.15	7-F	Xtuvw	2.40
2 in.	12-M	Xijkl	1.30	8-F	Xuvwx	2.80
2 1/2 in.	14-M	Xjklm	1.50	9-F	Xvwxy	3.60
3 in.	15-M	Xklmn	1.65	10-F	Xwxyz	4.60
3 1/2 in.	16-M	Xlmno	1.85	11-F	Xyzab	6.00
4 in.	17-M	Xmnop	2.15	12-F		9.00

Pipe Centers for Lathes

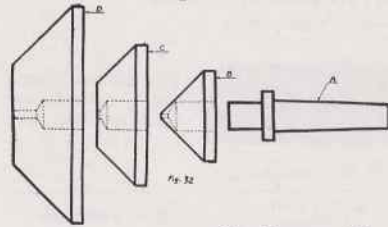

For machining pipe in the lathe. Taper Shank "A" fits either head spindle or tail spindle of lathe. The conical discs "B," "C," and "D" revolve on Taper Shank "A." Prices of discs larger than those listed furnished on request.

Net Factory Prices

ITEM	Catalog No.	Code Word	Price Each
Taper Shank "A" for 11" lathes	910-B	Xwbtm	\$ 3.00
Taper Shank "A" for 13", 15" lathes	910-C	Xacun	4.00
Taper Shank "A" for 16", 18" lathes	910-E	Xydivo	4.50
Taper Shank "A" for 21", 24" lathes	910-H	Xzewp	6.00
Disc "B" takes from 1/2" to 3" pipe	911-B	Xafxq	6.00
Disc "C" takes from 3" to 5" pipe	912-C	Xegyrr	9.00
Disc "D" takes from 5" to 8" pipe	913-D	Xdhz	15.00

Safety Lathe Dogs



Furnished in either heavy malleable iron or special drop forged steel. Price includes hardened tool steel headless set-screw and wrench.

Net Factory Prices

Capacity of Lathe Dog	MALLEABLE IRON			FORGED STEEL		
	Catalog No.	Code Word	Price Each	Catalog No.	Code Word	Price Each
3/8 in.	1-MH	Xzml	\$.60	1-FH	Xmyax	\$1.12
1/2 in.	2-MH	Xanpm	.70	2-FH	Xnzby	1.24
3/4 in.	4-MH	Xeoqn	.85	3-FH	Xoacz	1.36
1 in.	6-MH	Xdpro	1.00	4-FH	Xpbda	1.58
1 1/4 in.	8-MH	Xeqsp	1.10	5-FH	Xqeeb	1.90
1 1/2 in.	10-MH	Xftrq	1.25	6-FH	Xrdfe	2.24
1 3/4 in.	11-MH	Xgsur	1.40	7-FH	Xsegd	2.66
2 in.	12-MH	Xhtvs	1.55	8-FH	Xtife	3.10
2 1/2 in.	14-MH	Xiuwt	1.85	9-FH	Xugif	3.98
3 in.	15-MH	Xjvux	2.10	10-FH	Xvhjg	5.08
3 1/2 in.	16-MH	Xkwyv	2.25	11-FH	Xwikh	6.60
4 in.	17-MH	Xlxzw	2.60	12-FH	Xajli	9.74

Clamp Lathe Dogs

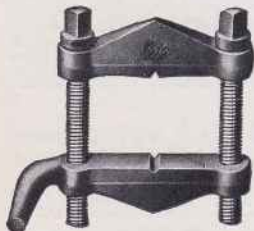

Made of heavy drop forged steel, carefully machined and hardened. Very practical for holding rectangular work. Each dog is boxed separately.

Net Factory Prices

Catalog No.	Capacity Between Screws	Extra Screws		Clamp Dog	
		Code Word	Price Each	Code Word	Price Each
160	1 1/4 in.	Xotle	\$.20	Xsxpi	\$3.00
161	2 1/4 in.	Xpumf	.30	Xtyqj	4.00
162	2 3/4 in.	Xqvng	.40	Xuzrk	5.00
163	3 1/2 in.	Xrwoh	.60	Xvasl	7.00

Special Boring and Turning Tool

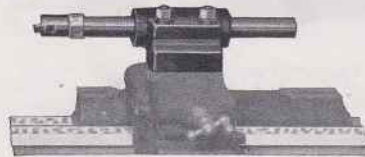

Designed for turning extra large diameters and for heavy duty boring. Will machine any diameter up to the maximum capacity of the lathe. Cutter bit is adjustable and may be set straight or at 45° angle. Price includes Holder, Boring Bar, Wrench and one High Speed Steel Cutter Bit.

Net Factory Prices

Size of Lathe	Cat. No.	Diameter of Bar	Code Word	Price Each	Size of Lathe	Cat. No.	Diameter of Bar	Code Word	Price Each
9 in.	443	5/8 in.	Xeiat	\$12.50	16 in.	447	1 1/2 in.	Ximex	\$20.00
11 in.	444	3/4 in.	Xfibu	12.50	18 in.	448	1 1/2 in.	Xjnyf	22.00
13 in.	445	1 1/8 in.	Xgkev	16.50	21 in.	449	1 3/4 in.	Xkocz	25.00
15 in.	446	1 1/4 in.	Xhldw	18.00	24 in.	450	1 3/4 in.	Xlpha	30.00

Combination Center Drill and Countersink



For drilling center hole and countersinking 60 degree angle for lathe center. Made of carbon tool steel, hardened and ground. Table shows correct size center drill for various sizes of work.

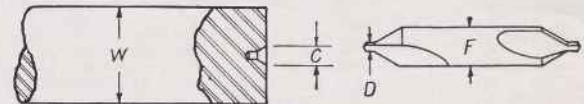

Net Factory Prices

Cat. No.	Diam. of Work "W"	Diam. of Countersink "C"	Diam. of Drill "D"	Body of Drill "F"	Code Word	Price Each	Code Word per Doz.	Price per Doz.
1-C	3/8" to 5/8"	1/8 in.	1/8 in.	1 1/2 in.	Xmqjb	\$.25	Xqpf	\$2.25
2-C	5/8" to 1"	1/4 in.	1/4 in.	1 3/4 in.	Xnrje	.30	Xrqb	2.75
3-C	1 1/4" to 2"	3/8 in.	3/8 in.	2 1/4 in.	Xoskd	.30	Xsrhc	2.75
4-C	2 1/4" to 4"	1/2 in.	1/2 in.	3 1/4 in.	Xpoez	.40	Xtsid	3.50

Center Gauge



No. 650

For testing the angle of 60 degree lathe centers. Also used in setting threading tools for cutting 60 degree "V" or U.S. Standard screw threads.
No. 650, Center gauge, for testing 60 degree Lathe Centers. Net Factory price, each. \$.50 Code word Xutje.



Centers, Drill Pads and Arbors for South Bend Lathes

The Centers, Drill Pads and Arbors listed below should form a part of the equipment of every shop. The tapers are accurately ground and can be used in both the Head and Tail Spindles of the various sizes of South Bend Lathes.

60 Degree Head Spindle Center



Made of tool steel, accurately ground all over. For use in head stock spindle of the lathe. Not hardened.

Net Factory Prices

Size of Lathe	9 in.	11 in.	13 in.	15 in.	16 in.	18 in.	21 in.	24 in.
Cat. No.	725A	725B	725C	725D	725E	725F	725G	725H
Code Word	Abest	Actor	Aders	Aegan	Afire	Agoem	Ahalt	Ajost
Net Price	\$2.00	\$2.25	\$2.75	\$2.75	\$2.75	\$2.75	\$3.50	\$3.50

Spur Center



Used for wood turning. Shank is ground to fit taper in Head Spindle of Lathe.

Net Factory Prices

Size of Lathe	9 in.	11 in.	13 in.	15 in.	16 in.	18 in.	21 in.	24 in.
Cat. No.	732A	732B	732C	732D	732E	732F	732G	732H
Code Word	Ibeck	Icons	Idols	Iguan	Ijong	Ikart	Ilure	Imalt
Net Price	\$3.00	\$3.00	\$4.00	\$4.00	\$4.00	\$4.00	\$5.00	\$5.00

60 Degree Tail Spindle Center



Made of tool steel, hardened and ground all over. For use in tail stock spindle of the lathe.

Net Factory Prices

Size of Lathe	9 in.	11 in.	13 in.	15 in.	16 in.	18 in.	21 in.	24 in.
Cat. No.	726A	726B	726C	726D	726E	726F	726G	726H
Code Word	Caten	Ceils	Cheat	Ciena	Clase	Cotin	Crave	Cubes
Net Price	\$2.25	\$2.50	\$3.00	\$3.00	\$3.00	\$3.00	\$3.75	\$3.75

Cup Center



Used for wood turning. Shank is ground to fit taper of Tail Spindle of Lathe.

Net Factory Prices

Size of Lathe	9 in.	11 in.	13 in.	15 in.	16 in.	18 in.	21 in.	24 in.
Cat. No.	733A	733B	733C	733D	733E	733F	733G	733H
Code Word	Jacks	Jealt	Jiped	Jober	Juvin	Jvaie	Jwelt	Jyork
Net Price	\$3.00	\$3.00	\$4.00	\$4.00	\$4.00	\$4.00	\$5.00	\$5.00

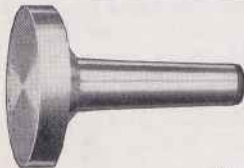

Drill Pad

Used in tail stock spindle to support flat work while being drilled. Shank is ground to fit taper in tail stock spindle.

Net Factory Prices

Size of Lathe	9 in.	11 in.	13 in.	15 in.	16 in.	18 in.	21 in.	24 in.
Cat. No.	727A	727B	727C	727D	727E	727F	727G	727H
Code Word	Dabed	Dears	Dingy	Dopet	Drunk	Dumbe	Dwelt	Dying
Net Price	\$3.00	\$3.00	\$4.00	\$4.00	\$4.00	\$4.00	\$5.00	\$5.00



Screw Center

Used in head spindle of lathe for wood turning. Best adapted to small flat work. Shank is ground to fit taper in Head Stock Spindle of Lathe.

Net Factory Prices

Size of Lathe	9 in.	11 in.	13 in.	15 in.	16 in.	18 in.	21 in.	24 in.
Cat. No.	731A	731B	731C	731D	731E	731F	731G	731H
Code Word	Kabar	Kelso	Kinty	Klink	Koden	Kring	Kultr	Kwank
Net Price	\$3.50	\$3.50	\$4.00	\$4.00	\$4.00	\$4.00	\$5.00	\$5.00



Crotch Center

Used in tail stock spindle to support and center round work while being drilled. Can also be used for flat work.

Net Factory Prices

Size of Lathe	9 in.	11 in.	13 in.	15 in.	16 in.	18 in.	21 in.	24 in.
Cat. No.	728A	728B	728C	728D	728E	728F	728G	728H
Code Word	Faint	Fever	Fiats	Flota	Found	Frail	Fumed	Fyolk
Net Price	\$3.00	\$3.00	\$4.00	\$4.00	\$4.00	\$4.00	\$5.00	\$5.00

Semi-Finished Drill Chuck Arbor



Long taper ground to fit head or tail spindle of lathe. Taper for Drill Chuck not finished. In ordering, state size of Drill Chuck.

Net Factory Prices

Size of Lathe	9 in.	11 in.	13 in.	15 in.	16 in.	18 in.	21 in.	24 in.
Cat. No.	730A	730B	730C	730D	730E	730F	730G	730H
Code Word	Navel	Nests	Niger	Novis	Noted	Nutro	Nyart	Nzead
Net Price	\$2.00	\$2.00	\$2.50	\$2.50	\$2.50	\$2.50	\$3.50	\$3.50

Blacksmith's Drill Chuck



Fits head or tail spindle of lathe. Used for holding blacksmith's drills and Woodruff keyway cutters, with standard 1/2-inch shank.

Net Factory Prices

Size of Lathe	9 in.	11 in.	13 in.	15 in.	16 in.	18 in.	21 in.	24 in.
Cat. No.	729A	729B	729C	729D	729E	729F	729G	729H
Code Word	Haven	Heave	Hiros	Honey	Hunch	Hwent	Hylar	Hzops
Net Price	\$3.00	\$3.00	\$4.00	\$4.00	\$4.00	\$4.00	\$5.00	\$5.00

Head Spindle Sleeve for South Bend Lathes



Made of steel and accurately ground on the outside to fit the taper in Head Stock Spindle. This Sleeve is bored Standard Morse Taper for lathe centers.

Net Factory Prices

Size of Lathe	9 in.	11 in.	13 in.	15 in.	16 in.	18 in.	21 in.	24 in.
Cat. No.	205A	205B	205C	205D	205E	205F	205G	205H
Code Word	Oabed	Obert	Ocind	Oduft	Oerst	Oflin	Ogoth	Ohavy
Price, Each	\$3.50	\$3.75	\$4.00	\$4.25	\$4.50	\$5.00	\$6.00	\$7.00

Practical Machine Shop Equipments

With Assortments of Tools and Chucks for South Bend Lathes

To aid our customers in selecting the correct size Chucks and Tools for the various sizes of South Bend Lathes we suggest the following assortments as practical for general machine work.

These tools are not included in the Lathe equipment but are supplied for the prices shown below. Any one of these tools, or the entire equipment, may be ordered.

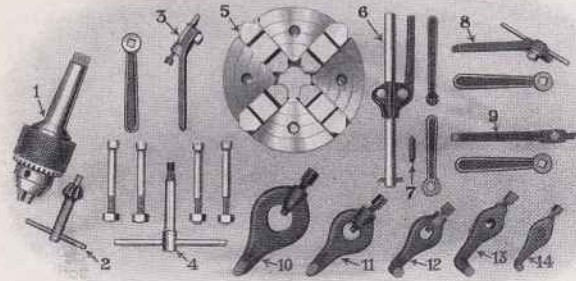

Tool and Chuck Assortment for South Bend Lathes

The illustration shows the Chucks and Tools that are included in the Special Tool Assortments. The figure numbers refer to the numbers in the illustration and should not be confused with catalog numbers. The Chucks, Tools, and Dogs in each assortment are the recommended sizes for that size lathe. Use catalog numbers and code words when ordering.

- | Fig. No. | Name of Part |
|---------------------|---|
| 1. | 3-Jaw Drill Chuck with Arbor Attached |
| 2. | Pinion Key for Drill Chuck |
| 3. | Formed Threading Tool and Wrench |
| 4. | Wrench and Cap Screws for 4-Jaw Independent Chuck |
| 5. | 4-Jaw Independent Lathe Chuck |
| 6. | Style "B" Patent Boring Tool and Wrenches |
| 7. | High Speed Steel Cutter Bits |
| 8. | Right Hand Patent Cutting-Off Tool and Wrench |
| 9. | Straight Shank Patent Turning Tool and Wrench |
| 10, 11, 12, 13, 14. | Are Malleable Lathe Dogs, 1/2-inch, 3/4-inch, 1-inch, 1 1/4-inch and 1 1/2-inch capacity. Other sizes may be ordered from list page 64. |

No. 1-B Shop Equipment with 9-inch Lathe Junior Bench Lathe

1 No. 22-YC, 9-in. x 3-ft. South Bend Junior Back Geared Screw Cutting Bench Lathe, 9 1/4-inch swing, 3-ft. bed, complete with Compound Rest, Countershaft and Regular Equipment.....\$155.00

1 No. 2106	6", 4-Jaw Independent Lathe Chuck.....	\$24.00	
	Fitting Chuck to Lathe including Chuck Back	7.00	
1 No. 1201	3-Jaw Drill Chuck, 1/2-inch capacity.....	8.00	
1 No. 709	Drill Chuck Arbor, fitted to Chuck.....	2.50	
1 No. 849-S	Patent Turning Tool, straight shank.....	2.40	
1 No. 865	Patent Threading Tool.....	3.75	
1 No. 429	Patent Boring Tool, Style B.....	4.40	
1 No. 881-R	Patent Cutting Off Tool (R.H.).....	2.60	
1 Set (5)	Malleable Lathe Dogs, 1/2", 3/4", 1", 1 1/4", 1 1/2"	4.05	58.70

Total: F. O. B. cars South Bend (Code Word Brink).....\$213.70
Reduced Prices Effective October 1st, 1927

No. 4-B Shop Equipment with 13-inch Lathe Quick Change Gear Lathe

1 No. 86-B, 13-in. x 5-ft. South Bend Screw Cutting Quick Change Gear Lathe, 13 1/4-inch swing, 5-ft. bed, complete with Compound Rest, Countershaft and Regular Equipment.....\$402.00

1 No. 2108	8", 4-Jaw Independent Lathe Chuck.....	\$28.00	
	Fitting Chuck to Lathe including Chuck Back.....	8.00	
1 No. 1201	3-Jaw Drill Chuck, 1/2-inch capacity.....	8.00	
1 No. 713	Drill Chuck Arbor, fitted to Chuck.....	3.00	
1 No. 852-S	Patent Turning Tool, straight shank.....	3.00	
1 No. 867	Patent Threading Tool.....	4.50	
1 No. 431	Patent Boring Tool, Style B.....	5.25	
1 No. 883-R	Patent Cutting Off Tool (R.H.).....	3.25	
1 Set (5)	Malleable Lathe Dogs, 1/2", 3/4", 1", 1 1/2", 2"	4.45	67.45

Total: F.O.B. cars South Bend (Code Word Grape) .. \$469.45

No. 2-B Shop Equipment with 9-inch Lathe Quick Change Gear Lathe

1 No. 82-Y, 9-in. x 3 ft. South Bend Screw Cutting Quick Change Gear Lathe, 9 1/4-inch swing, 3 ft. bed, complete with Compound Rest, Countershaft and Regular Equipment.....\$270.00

1 No. 2106	6", 4-Jaw Independent Lathe Chuck.....	\$24.00	
	Fitting Chuck to Lathe including Chuck Back.....	7.00	
1 No. 1201	3-Jaw Drill Chuck, 1/2-inch capacity..	8.00	
1 No. 709	Drill Chuck Arbor, fitted to Chuck...	2.50	
1 No. 849-S	Patent Turning Tool, straight shank..	2.40	
1 No. 865	Patent Threading Tool.....	3.75	
1 No. 429	Patent Boring Tool, Style B.....	4.40	
1 No. 881-R	Patent Cutting Off Tool (R.H.).....	2.60	
1 Set (5)	Malleable Lathe Dogs, 1/2", 3/4", 1", 1 1/4", 1 1/2"	4.05	58.70

Total: F.O.B. cars South Bend (Code Word Bulet) .. \$328.70

No. 5-B Shop Equipment with 16-inch Lathe Quick Change Gear Lathe

1 No. 92-E, 16-in. x 8-ft. South Bend Screw Cutting Quick Change Gear Lathe, 16 1/4-inch swing, 8-ft. bed, complete with Compound Rest, Countershaft and Regular Equipment.....\$570.00

1 No. 2110	10", 4-Jaw Independent Lathe Chuck.....	\$36.00	
	Fitting Chuck to Lathe including Chuck Back.....	9.00	
1 No. 1201	3-Jaw Drill Chuck, 1/2-inch capacity..	8.00	
1 No. 716	Drill Chuck Arbor, fitted to Chuck....	3.00	
1 No. 853-S	Patent Turning Tool, straight shank..	3.60	
1 No. 868	Patent Threading Tool.....	5.75	
1 No. 432	Patent Boring Tool, Style B.....	6.90	
1 No. 884-R	Patent Cutting Off Tool (R.H.).....	4.00	
1 Set (5)	Malleable Lathe Dogs, 1/2", 3/4", 1", 1 1/2", 2"	4.45	80.70

Total: F.O.B. cars South Bend (Code Word Molar) .. \$650.70

No. 3-B Shop Equipment with 11-inch Lathe Quick Change Gear Lathe

1 No. 84-A, 11-in. x 4-ft. South Bend Screw Cutting Quick Change Gear Lathe, 11 1/4-inch swing, 4-ft. bed, complete with Compound Rest, Countershaft and Regular Equipment.....\$335.00

1 No. 2106	6", 4-Jaw Independent Lathe Chuck.....	\$24.00	
	Fitting Chuck to Lathe including Chuck Back.....	7.50	
1 No. 1201	3-Jaw Drill Chuck, 1/2-inch capacity..	8.00	
1 No. 711	Drill Chuck Arbor, fitted to Chuck....	2.50	
1 No. 851-S	Patent Turning Tool, straight shank..	2.55	
1 No. 866	Patent Threading Tool.....	3.75	
1 No. 430	Patent Boring Tool, Style B.....	4.40	
1 No. 882-R	Patent Cutting Off Tool (R.H.).....	2.75	
1 Set (5)	Malleable Lathe Dogs, 1/2", 3/4", 1", 1 1/4", 1 1/2"	4.05	59.50

Total: F.O.B. cars South Bend (Code Word Envel) .. \$394.50

No. 6-B Shop Equipment with 18-inch Lathe Quick Change Gear Lathe

1 No. 94-G, 18-in. x 10-ft. South Bend Screw Cutting Quick Change Gear Lathe, 18 1/4-inch swing, 10-ft. bed, complete with Compound Rest, Countershaft and Regular Equipment..\$750.00

1 No. 2112	12", 4-Jaw Independent Lathe Chuck.....	\$42.00	
	Fitting Chuck to Lathe including Chuck Back.....	10.00	
1 No. 1201	3-Jaw Drill Chuck, 1/2-inch capacity..	8.00	
1 No. 718	Drill Chuck Arbor, fitted to Chuck....	3.00	
1 No. 853-S	Patent Turning Tool, straight shank..	3.60	
1 No. 868	Patent Threading Tool.....	5.75	
1 No. 432	Patent Boring Tool, Style B.....	6.90	
1 No. 884-R	Patent Cutting Off Tool (R.H.).....	4.00	
1 Set (5)	Malleable Lathe Dogs, 3/4", 1 1/2", 2", 2 1/2", 3"	6.20	89.45

Total: F.O.B. cars South Bend (Code Word Super) .. \$839.45

South Bend Lathes Boxed for Export Shipment

South Bend Lathes have been manufactured for more than twenty years and we have been exporting them for eighteen years. There are now more than 37,000 South Bend Lathes in use in 64 different countries throughout the world.

Tested Before Shipment

Each South Bend Lathe is operated and tested before shipment from our factory.

It is placed under belt and operated under its own power. It is then given a final inspection and undergoes a series of tests before it is packed for shipment and a record of these tests is filed in our office.

After the lathe is tested, all the large parts are removed, oiled, and greased, and carefully packed in one strongly constructed shipping case, see illustration above. It is bound on the outside with steel tape and lined on the inside with a water proof two-ply kraft paper. All lathe parts are blocked solid in the box so that they can not move while in transit.

Boxed for Ocean Shipment

From twenty years' experience in boxing for ocean shipment, we know how important it is for the lathe to be packed and boxed properly to withstand the rough handling that it receives in transit and when loaded and unloaded from ocean steamers. Our method of packing is secure and insures safe delivery of the South Bend Lathe to you.

Export Lathe Prices, F.O.B. Cars New York City, Boxed for Ocean Shipment

For export prices on South Bend Lathes, write for export supplement No. 88-E, which contains all export prices f.o.b. cars New York City, boxed for ocean shipment, also metric specifications of dimensions and weights of lathes and shipping cases. When requested, we will be pleased to quote C.I.F. (Cost, Insurance and Freight), or prices of Lathes delivered to any port in the world.

Boxing for Mule Back Transportation

Any size South Bend Lathe can be boxed in several small cases suitable for mule back transportation at an additional cost. The lathe bed must be boxed in one case as it is cast in one piece.

Size of Lathe

The size of a Screw Cutting Lathe is determined by the Swing over the Bed and the Length of the bed (see illustration).

A—represents the Swing Over Bed.
R—the Radius, or one-half of the Swing.
C—represents the Length of the Bed.
B—represents the Distance between Centers when the end of the tailstock is flush with the end of the Bed.

European tool manufacturers determine the size of a lathe by its radius or center distance: for example, an 8-inch center lathe is a lathe having a radius of 8 inches. What the European terms an 8-inch center lathe, United States manufacturers term a 16-inch swing lathe.

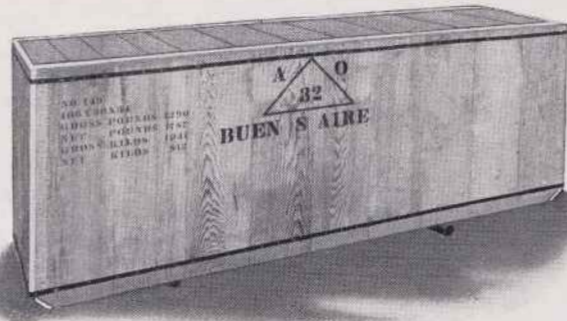

South Bend Lathe Boxed for Ocean Shipment

Tornos South Bend Encajonados Para Exportación

Los tornos South Bend han sido fabricados por más de veinte años y los hemos estado exportando durante dieciocho años.

En la actualidad hay en uso más de 37,000 tornos South Bend distribuidos en 64 países de todo el mundo.

Probados Antes Del Embarque

Cada torno South Bend antes de ser embarcado, se pone en trabajo y se ensaya en nuestra fabrica, poni-

éndolo en movimiento con la correa de transmisión e inspeccionándolo minuciosamente en todas y cada una de sus partes, que son sometidas una por una y en conjunto a una serie de pruebas, cuyos resultados se archivan en nuestras oficinas.

Después de que cada torno se inspecciona y prueba así, se desmontan sus partes, aceitándolas, engrasándolas y empacándolas cuidadosamente en una sólida caja construida ad hoc (vease ilustración arriba) fuertemente reforzada en su parte exterior con cinchos de acero y forrada en su interior con papel de empaque impermeable. Todas las piezas del torno se aseguran sólidamente en la caja de manera que no se muevan en el trayecto.

Encajonado Para Transporte Marítimo

Con veinte años de experiencia en nuestro ramo, sabemos lo importante que es el empacar y encajonar debidamente los tornos para que puedan resistir el maltrato que sufren durante la travesía, sobre todo en las maniobras de carga y descarga de los vapores. Nuestro método de empaque es eficaz y garantiza a nuestros clientes la entrega del torno South Bend en perfecto estado.

Precios De Exportación De Los Tornos, F.O.B. Carros En Nueva York, Encajonados Para Transporte Maritimo

Para precios de exportación de los tornos South Bend, pidásenos el Suplemento de Exportación No. 88-E que contiene todos los precios de exportación f.o.b. en Nueva York, empacados para transporte maritimo, asi como tambien los pesos y medidas de las cajas y los tornos en el sistema metrico. Cuando se nos pida cotizaremos gustosos C.I.F. (Costo, Incluyendo Seguro y Flete), o sea precios de los tornos entregados en cualquier puerto de el mundo.

Para Transporte a Lomo de Mula

Cualquier torno South Bend puede empacarse en varias cajas chicas apropiadas para ser transportadas a lomo de mula, mediante un costo adicional. El banco del torno por ser una sola pieza se empaca en una caja separada.

Tamaño del Torno

El tamaño de un torno de abrir roscas, se determina por el volteo sobre el banco y por el largo de este. (Vease ilustración).

A—representa el volteo sobre el banco.
R—el radio o una mitad del volteo.
C—representa el largo del banco.
B—representa la distancia entre los centros cuando la contrapunta queda embutida en el banco.

Los fabricantes Europeos determinan el tamaño de un torno por su radio o distancia del centro; por ejemplo un torno de ocho pulgadas de centro es aquel que tiene un radio de ocho pulgadas, llamándosele a este en los Estados Unidos un torno de 16 pulgadas de volteo.

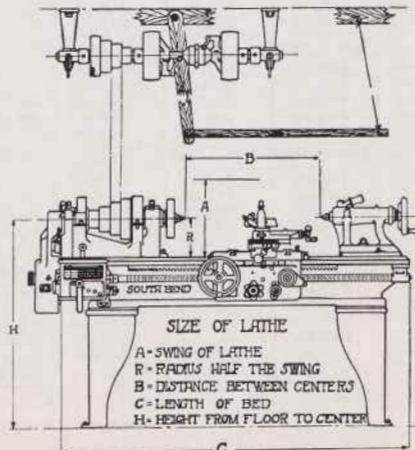

Wall Type Simplex Motor Drive for South Bend Lathes

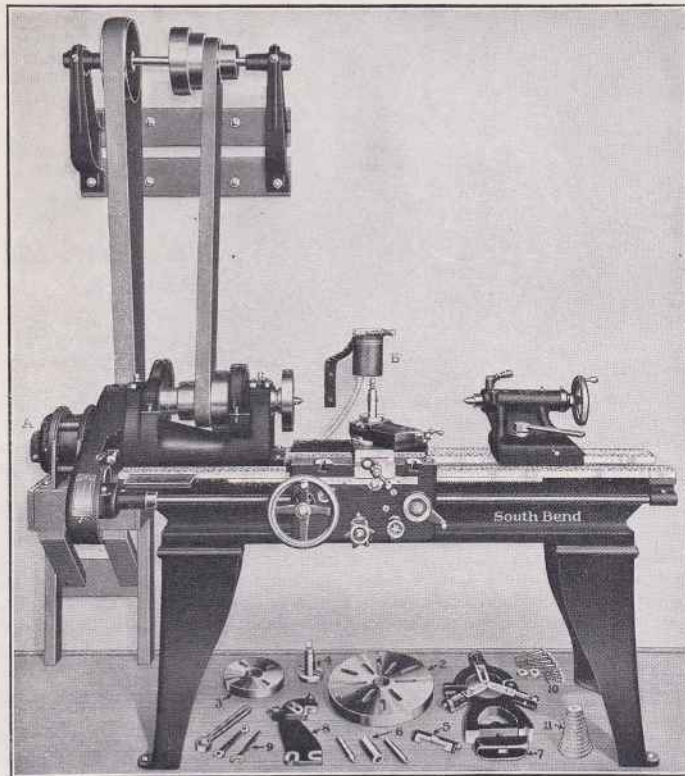

No. 541-C—16-inch x 6-ft. Wall Type Simplex Motor Driven Lathe
Equipment Illustrated under Lathe Is Included in Price.

The Wall Type Simplex Motor Drive Attachment illustrated, can be used with South Bend Quick Change Gear or Standard Change Gear Lathes, straight bed or gap bed types. This is a practical and inexpensive motor drive for a screw cutting lathe for a shop that is not equipped with line shafting.

The Simplex Wall Type Motor Drive Attachment consists of a 1200 R.P.M. reversible motor (A) which may be located on a shelf or any other convenient place, and a reversing switch, drum type (B) which controls the starting, stopping and reversing of the lathe spindle. The switch may be attached in any position convenient for the operator. The Simplex Countershaft is shown attached to the wall in a position so that the countershaft cone lines up with the spindle cone of the lathe.

Working blue prints of wiring diagrams for setting up and installing the Wall Type Simplex Motor Drive are included in the equipment of each lathe.

Motor Specifications. When ordering a Simplex Motor Drive Lathe give the following information regarding the electric current to be used so that the proper style and type of Reversing Motor can be furnished:

- If alternating, state exact voltage, phase, and cycle, and number of wires.
- If direct, state exact voltage only.

Electrical Equipment included in the price of the Simplex Motor Driven Lathe consists of a 1200 R.P.M. Reversing Motor, Reversing Switch (Drum Type), Wiring Diagram and installation Blue Print.

Net Factory Prices of South Bend Lathes with Wall Type Simplex Motor Drive

Prices Include Lathe, Reversing Motor, Reversing Switch (Drum Type) and Lathe Equipment

Swing Over Bed	Length of Bed	Size of Motor	Approx. Weight Crated	Quick Change Gear Lathes					Standard Change Gear Lathes				
				Catalog Number of Lathe	Code Word	With 3 Phase 60 Cycle A.C. Motor	With Single Phase 60 Cycle A.C. Motor	With Direct Current Motor	Catalog Number of Lathe	Code Word	With 3 Phase 60 Cycle A.C. Motor	With Single Phase 60 Cycle A.C. Motor	With Direct Current Motor
9-inch South Bend Wall Type Simplex Motor Driven Lathes													
9 1/4 in.	2 1/2 ft.	1/4 H.P.	495 lbs.	582-X	Bacon	\$323.00	\$ 338.00	\$ 325.00	531-X	Brief	\$288.00	\$ 303.00	\$ 290.00
9 1/4 in.	3 ft.	1/4 H.P.	515 lbs.	582-Y	Benie	328.00	343.00	330.00	531-Y	Buete	293.00	308.00	295.00
9 1/4 in.	3 1/2 ft.	1/4 H.P.	535 lbs.	582-Z	Biway	333.00	348.00	335.00	531-Z	Bvret	298.00	313.00	300.00
9 1/4 in.	4 ft.	1/4 H.P.	555 lbs.	582-A	Blite	338.00	353.00	340.00	531-A	Bwlap	303.00	318.00	305.00
9 1/4 in.	4 1/2 ft.	1/4 H.P.	575 lbs.	582-R	Boley	343.00	358.00	345.00	531-R	Bzrow	308.00	323.00	310.00
11-inch South Bend Wall Type Simplex Motor Driven Lathes													
11 1/4 in.	3 ft.	3/8 H.P.	725 lbs.	584-Y	Eanem	399.00	425.00	409.00	533-Y	Efavr	364.00	390.00	374.00
11 1/4 in.	3 1/2 ft.	1/2 H.P.	750 lbs.	584-Z	Ebhul	404.00	430.00	414.00	533-Z	Eglat	369.00	395.00	379.00
11 1/4 in.	4 ft.	1/2 H.P.	775 lbs.	584-A	Echop	409.00	435.00	419.00	533-A	Ehuka	374.00	400.00	384.00
11 1/4 in.	5 ft.	1/2 H.P.	855 lbs.	584-B	Edger	419.00	445.00	429.00	533-B	Eimar	384.00	410.00	394.00
13-inch South Bend Wall Type Simplex Motor Driven Lathes													
13 1/4 in.	4 ft.	3/4 H.P.	1135 lbs.	586-A	Gaols	471.00	534.00	479.00	535-A	Glitr	421.00	484.00	429.00
13 1/4 in.	5 ft.	3/4 H.P.	1185 lbs.	586-B	Genus	483.00	546.00	491.00	535-B	Guber	433.00	496.00	441.00
13 1/4 in.	6 ft.	3/4 H.P.	1245 lbs.	586-C	Gipon	495.00	558.00	503.00	535-C	Greta	445.00	508.00	453.00
13 1/4 in.	7 ft.	3/4 H.P.	1285 lbs.	586-D	Gondo	507.00	570.00	515.00	535-D	Gritt	457.00	520.00	465.00
13 1/4 in.	8 ft.	3/4 H.P.	1345 lbs.	586-E	Gnats	519.00	582.00	527.00	535-E	Gwarz	469.00	532.00	477.00
15-inch South Bend Wall Type Simplex Motor Driven Lathes													
15 1/4 in.	5 ft.	1 H.P.	1575 lbs.	588-B	Lambs	565.00	637.00	643.00	539-B	Lobst	505.00	577.00	583.00
15 1/4 in.	6 ft.	1 H.P.	1650 lbs.	588-C	Leban	580.00	652.00	658.00	539-C	Lochs	520.00	592.00	598.00
15 1/4 in.	7 ft.	1 H.P.	1725 lbs.	588-D	Lectu	595.00	667.00	673.00	539-D	Lodes	535.00	607.00	613.00
15 1/4 in.	8 ft.	1 H.P.	1835 lbs.	588-E	Liaso	610.00	682.00	688.00	539-E	Luanne	550.00	622.00	628.00
15 1/4 in.	10 ft.	1 H.P.	2000 lbs.	588-G	Libra	640.00	712.00	718.00	539-G	Lydia	580.00	652.00	658.00
16-inch South Bend Wall Type Simplex Motor Driven Lathes													
16 1/4 in.	6 ft.	1 H.P.	1975 lbs.	592-C	Mafia	630.00	702.00	708.00	541-C	Mifed	570.00	642.00	648.00
16 1/4 in.	7 ft.	1 H.P.	2055 lbs.	592-D	Marts	645.00	717.00	723.00	541-D	Modes	585.00	657.00	663.00
16 1/4 in.	8 ft.	1 H.P.	2135 lbs.	592-E	Merit	660.00	732.00	738.00	541-E	Motif	600.00	672.00	678.00
16 1/4 in.	10 ft.	1 H.P.	2295 lbs.	592-G	Mexia	690.00	762.00	768.00	541-G	Muebl	630.00	702.00	708.00
16 1/4 in.	12 ft.	1 H.P.	2455 lbs.	592-H	Midas	735.00	807.00	813.00	541-H	Myers	675.00	747.00	753.00
18-inch South Bend Wall Type Simplex Motor Driven Lathes													
18 1/4 in.	6 ft.	2 H.P.	2490 lbs.	594-C	Santa	749.00	861.00	860.00	543-C	Soest	684.00	796.00	795.00
18 1/4 in.	7 ft.	2 H.P.	2690 lbs.	594-D	Safro	774.00	886.00	885.00	543-D	Sofas	709.00	821.00	820.00
18 1/4 in.	8 ft.	2 H.P.	2790 lbs.	594-E	Secul	799.00	911.00	910.00	543-E	Sogie	734.00	846.00	845.00
18 1/4 in.	10 ft.	2 H.P.	2990 lbs.	594-G	Senat	849.00	961.00	960.00	543-G	Suelt	784.00	896.00	895.00
18 1/4 in.	12 ft.	2 H.P.	3290 lbs.	594-H	Siele	914.00	1026.00	1025.00	543-H	Suife	849.00	961.00	960.00
18 1/4 in.	14 ft.	2 H.P.	3690 lbs.	594-K	Sifon	974.00	1086.00	1085.00	543-K	Sypro	909.00	1021.00	1020.00

Prices on 21-inch and 24-inch Lathes with Wall Type Simplex Motor Drive furnished on request.

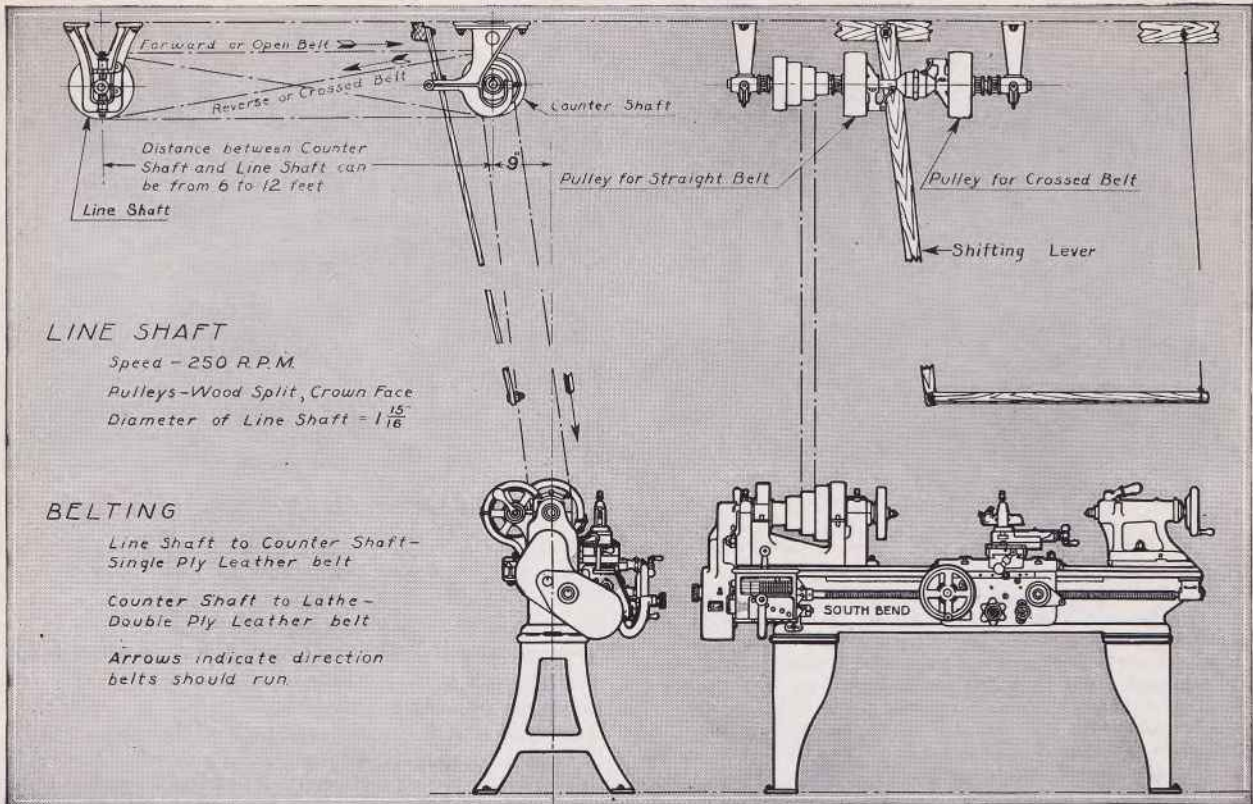

Front and Side View of Lathe with Overhead Countershaft Drive

The Overhead Countershaft Drive is the most popular type of drive used in industry. The Countershaft is driven from the line shaft. The advantage is that a number of other machines can also be driven from the same line shaft.

Installation Plan Blue Prints

The drawing at the right is a reduced cut of a blue print 9x18 inches which we furnish with the equipment of the lathe showing how to install and erect the lathe, the size and speed of pulleys and line shaft, the height and width of the bench, etc. It also contains instructions for levelling and setting up the lathe.

Foundation Plan Blue Prints

Foundation plan blue prints can be supplied for any size South Bend Lathe. These blue prints show the distance between bolt holes of floor leg lathes where they are fastened to the floor. It also shows the location for bolts for the legs of lathe when laying a concrete floor in a new shop.

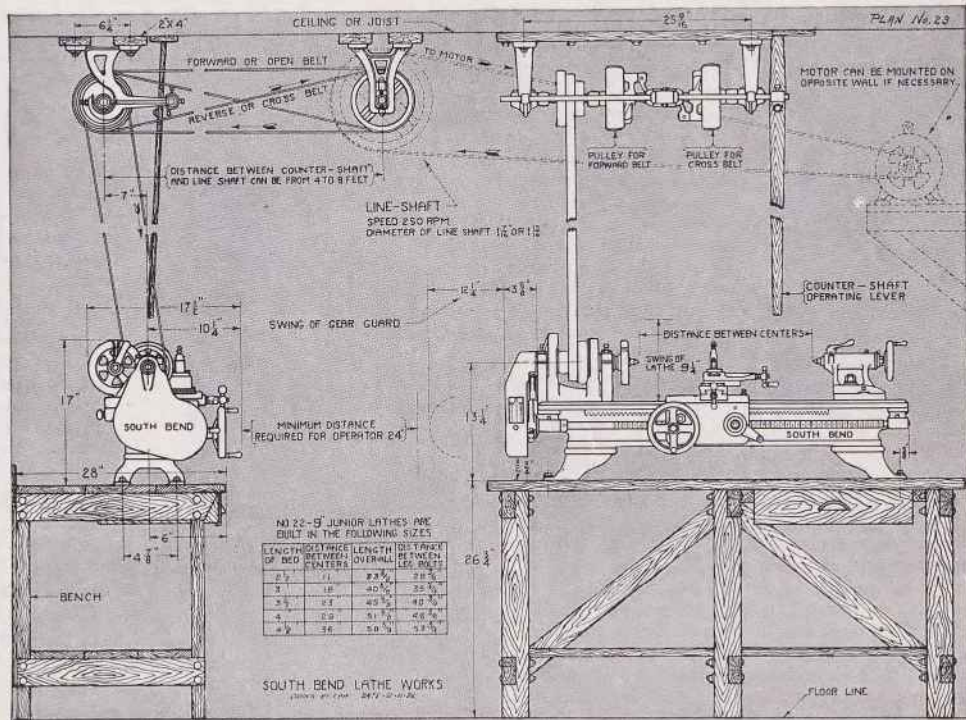

Overhead Countershaft Drive for 9-inch New Model Bench Lathe

The illustration shows the erection plan of a 9-inch Bench Lathe with Overhead Countershaft Drive. The principal dimensions of Lathe and bench show the space required for the Lathe.

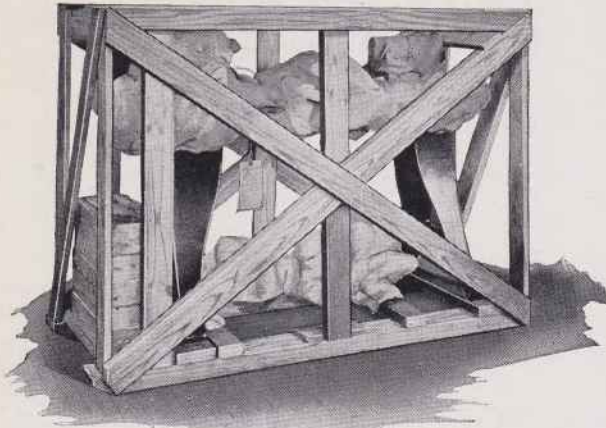

A Lathe Crated for Rail Shipment

The illustration above shows a New South Bend 16-inch Lathe skidded and crated for domestic shipment, that is, by rail to any point in the United States, Canada and Northern Mexico. In preparing lathes for shipment all polished parts are greased to prevent rusting, each unit is wrapped securely with heavy paper so as to prevent dust or dirt accumulating in the mechanism. The small parts are packed in a strong box which is nailed to the skids. The lathe is then skidded and crated so it will ride without damage.

Safe Arrival of Lathe Guaranteed

We have shipped more than 37,000 South Bend Lathes during the past 21 years and owing to the practical method of packing and crating we can guarantee the safe arrival of your lathe, and protect you against any loss or damage while in transit.

"How to Run a Lathe"

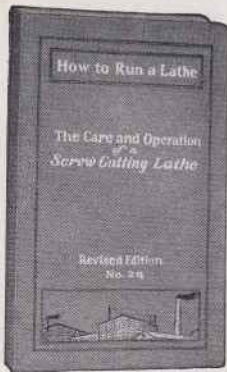

"How to Run a Lathe" is an authoritative manual covering the fundamental operations of the modern screw cutting lathe. It is a very valuable book for the mechanic as it contains complete instructions on the setting up, the care and operation of the screw cutting lathe.

This 144-page book contains over 300 practical illustrations. A copy of this book is included with the equipment of each South Bend Lathe.

Price each, postpaid. . . . \$0.25
Coin or Stamps of Any Country Accepted

Partial List of Contents

- The grinding and setting of lathe tools.
- Cutting right hand and left hand screw threads.
- Cutting Acme threads and square threads.
- Installing and starting a lathe.
- Lining up and hanging the countershaft.
- The cutting speeds and feed for metals.
- Cutting internal and external screw threads.
- The turning and boring of tapers.
- Operating the cross and automatic feeds.
- The care and operation of lathe centers.
- The reading of a micrometer caliper.
- Table of decimal equivalents of an inch.
- Table of metric linear measure.
- Method of levelling a lathe.
- Calculating the size and speed of pulleys.
- 300 other shop kinks for the mechanic.

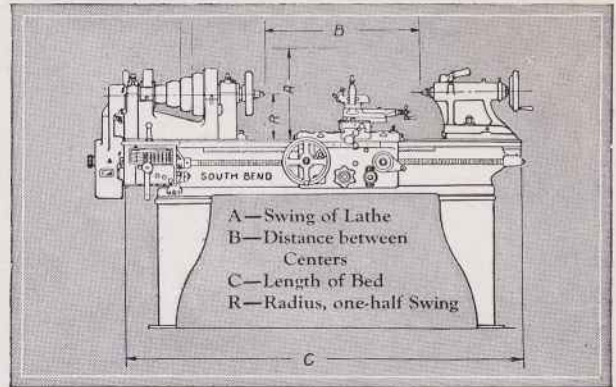

How to Determine the Size of a Lathe

The size of a Screw Cutting Lathe is determined by the swing over bed and the length of bed. See drawing above.

- A—represents the swing over bed.
- B—represents the distance between centers when end of tail stock is flush with end of bed.
- C—represents the length of bed.
- R—represents the radius, one-half of the swing.

European mechanics determine the size of the lathe by its radius or center distance. What the European terms an 8-inch center lathe, the Americans call a 16-inch swing lathe.

Foundation Plans for Erecting Lathes

Foundation Plans, Blue Prints and Instructions for the erection and installation of the Lathe will be found packed with the Lathe. These instructions will guide the mechanic in setting up the Lathe and selecting the proper size of pulleys to obtain the desired speed at which the Lathe should be operated, etc., etc.

Booklets Describing Each Size Lathe



We are preparing booklets on each size lathe devoted exclusively to the illustration and description of the lathe in the various types and drives showing prices on the lathes and attachments, also chucks, tools, etc.

If you are interested in any particular size lathe and wish more detailed information than is shown in this catalog write for the booklet specifying the name and number as shown below.

Lathe Booklets

- No. 22 9-inch Junior Screw Cutting Lathe.
- No. 9 { 9-inch Quick Change Screw Cutting Lathe.
9-inch Standard Change Screw Cutting Lathe.
- No. 11 { 11-inch Quick Change Screw Cutting Lathe.
11-inch Standard Change Screw Cutting Lathe.
- No. 13 { 13-inch Quick Change Screw Cutting Lathe.
13-inch Standard Change Screw Cutting Lathe.
- No. 15 { 15-inch Quick Change Screw Cutting Lathe.
15-inch Standard Change Screw Cutting Lathe.
- No. 16 { 16-inch Quick Change Screw Cutting Lathe.
16-inch Standard Change Screw Cutting Lathe.
- No. 18 { 18-inch Quick Change Screw Cutting Lathe.
18-inch Standard Change Screw Cutting Lathe.



General Information on South Bend Lathes

The No. 88 Catalog

This No. 88 Catalog contains all the latest prices on South Bend Lathes, Tools and Attachments. Therefore, destroy all old Catalogs, as they contain prices and specifications that are out of date.

Net Selling Prices

The prices shown in this catalog are our lowest net selling prices on South Bend Lathes, tools and attachments. There is no reduction from these prices, our policy is one price to all.

Use Code Words When Ordering

Use our code words when ordering South Bend Lathes, tools and attachments, especially if you order by telegram or cablegram. The code word simplifies ordering, reduces the cost of telegrams and cablegrams.

Attachments for South Bend Lathes

Special attachments that equip the lathe for various classes of work are illustrated, described and priced in this Catalog. These attachments can be fitted to the lathe at the time of shipment, or afterwards in the customer's own shop.

Erection Plan Blue Prints

Erection Plan blue prints and instructions for the erection and installation of the lathe will be found packed in the box with the lathe equipment. These instructions will be of assistance to the mechanic in the installation of the lathe.

Foundation Plan Blue Prints

Foundation plan blue prints can be supplied for any size South Bend Lathe. These plans show the distance between bolt holes of the floor legs on the various sizes of South Bend Lathes, showing the proper location of the bolts for the lathe when laying a concrete floor in a new shop.

Reversing Motors and Switches

We recommend that a Motor Drive Screw Cutting Lathe be operated with a reversing motor of 1200 R.P.M. and a reversing switch for controlling the reversing motor. This is the most efficient type of motor drive for a screw cutting lathe because the reversing feature is used so much in cutting screw threads of all kinds.

Non-Reversing Motors

South Bend Motor Driven Lathes can be supplied with non-reversing 1800 R.P.M. motors and non-reversing switches at a much lower price, but this type of motor drive equipment is not efficient or practical on a screw cutting lathe for general machine work.

A South Bend Lathe Will Last a Lifetime

A South Bend Screw Cutting Lathe should last a lifetime and give excellent service during that time. All that is necessary is to give the lathe the proper care, keep it clean and well oiled.

Sold in All Principal Cities

South Bend Lathes are sold by the leading machinery and supply dealers in all the principal cities of the United States. The dealers usually carry South Bend Lathes on their floor, where they may be seen and examined.

Information on various sizes and types of lathes, also specifications, prices, etc., can be obtained from the dealer.

We will be pleased to mail the name and address of our dealer in the city nearest your home.

Guarantee of Lathe

Each South Bend Lathe is guaranteed to be accurate, mechanically perfect, and to give entire satisfaction and the service you have a right to expect because you pay for reliable lathe value.

We will ship a lathe anywhere in the United States for a thirty-day trial in your own shop. If you are dissatisfied with the lathe in any way, within that time, ship it back to us, and we will pay the return freight charges and refund your money.

Prompt Delivery on South Bend Lathes

More than 1600 South Bend Lathes are in the process of manufacture in our factory at all times. There are also some assembled units in stock and several of the popular selling size lathes crated ready for shipment. This stock of lathes enables us to make prompt delivery on the popular selling sizes.

To accommodate our customers we carry a large stock of electric motors, lathe chucks, drill chucks and lathe tools, etc., also attachments and accessories for all sizes of South Bend Lathes. This makes it possible for you to purchase any equipment shown in this catalog and have it packed with your lathe shipment.

Send a Catalog to Your Friend

If you have a friend who is interested in mechanics and you think he would like to receive a copy of this catalog, give us his name and address. We will be pleased to mail him a copy postpaid, no charge. You will be doing him a favor as well as ourselves.

When you receive this catalog, if you are not interested, please pass it on to someone who is interested in mechanics and we feel sure he will appreciate it.

The Proper Lathe for Your Work

When in doubt as to the size and type lathe, attachments, chucks and tools practical for your work, write to us describing the class of work you wish to handle. We will select a lathe that we will recommend and send you an itemized quotation showing you the total cost delivered to your city.

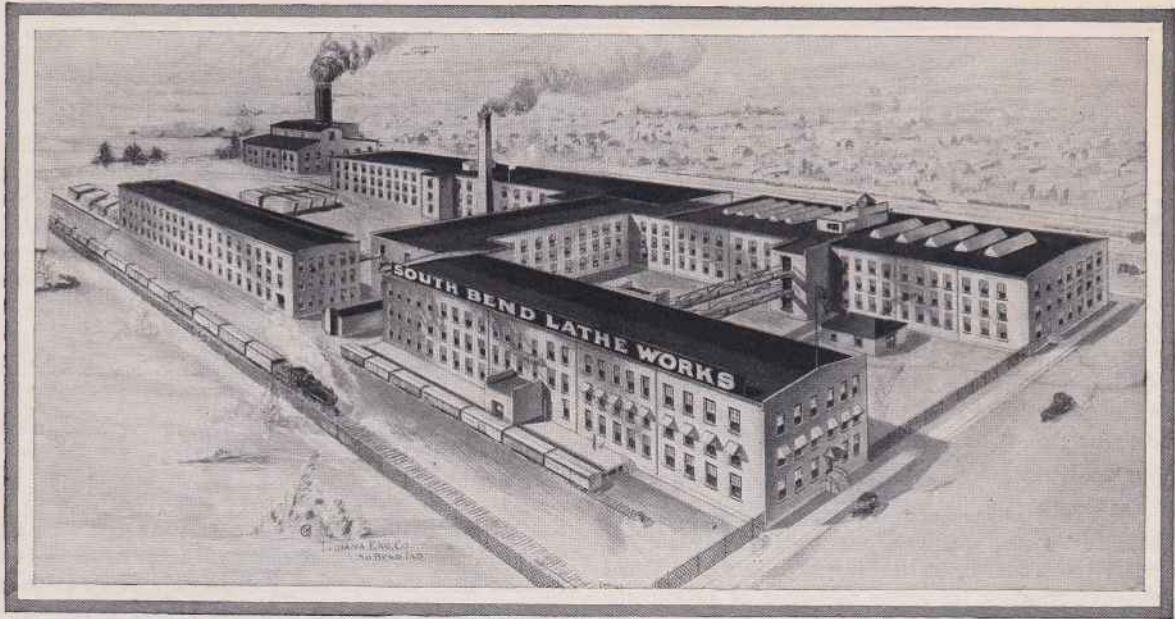

The Plant of the South Bend Lathe Works

South Bend Lathe Works History, Resources and Policy

History. The South Bend Lathe Works was established at South Bend, Indiana, the year 1906 and has operated continuously for more than twenty-one (21) years building South Bend Screw Cutting Engine Lathes.

The New Model South Bend Lathe was brought out in 1926 and 1927 at a cost of more than \$250,000.00. This New Model Lathe is a marvel of accuracy and will compare favorably with any other Screw Cutting Engine Lathe built of similar size. The New Model Lathe will meet the accuracy and precision requirements of the most skilled mechanic.

37,000 South Bend Screw Cutting Lathes have been produced and sold in the United States and sixty-five countries throughout the World.

Plant Facilities. Over \$1,000,000.00 is invested in the South Bend Lathe Plant, which covers four (4) acres and contains 180,000 square feet of floor space and has a manufacturing capacity of 4,000 lathes per annum. The plant is equipped with the most modern machinery, jigs, tools and fixtures necessary for the manufacture of high grade quality lathes.

300 Skilled and trained men that have had years of experience in the manufacture of lathes insure the highest class of workmanship. The business is devoted exclusively to the manufacture of South Bend Lathes.

64 accuracy tests made on the parts of each lathe by precision instruments during the process of manufacture insures the accuracy and interchangeability of parts of the New Model Lathe.

The New Model South Bend Lathe is designed for Industrial Work — for the Manufacturing Plant, for Maintenance and Tool Room Work, and for general Machine Shop Work.

Guarantee. Each South Bend Lathe is guaranteed to be accurate, mechanically perfect, and to give entire satisfaction and the service you have a right to expect because you pay for reliable lathe value. We will ship a lathe anywhere in the United States for a thirty day trial in your own shop. If you are dissatisfied with the lathe in any way, within that time, ship it back to us, and we will pay the return freight charges and refund your money.

Policy. The broad principles on which the business of the South Bend Lathe Works is conducted and upon which it has prospered for more than twenty-one (21) years is to give satisfaction and service to the users of South Bend Lathes.

Visitors are always welcome to go through our factory to see how South Bend Lathes are built. We plan trips through the factory so that those interested may visit all departments including our demonstration room where different model lathes are set up and in operation.

South Bend is located in the northern part of Indiana, seven (7) miles south of the Michigan State Line and 86 miles east of Chicago on the New York Central and Grand Trunk Railroads. The Lincoln Highway crosses the Dixie Highway at South Bend. Easily accessible by railroad or automobile.

SOUTH BEND LATHE WORKS

SOUTH BEND, IND., U. S. A.

————— SOUTH BEND LATHE WORKS ————— 325 EAST WASHINGTON ST. ————— SOUTH BEND, IND. —————

A Partial List of U. S. A. Industries Using South Bend Lathes

Automobile Mfrs.

Studebaker Corporation
Ford Motor Co.
Chevrolet Co.
Packard Motor Car Co.
Lincoln Motor Co.

Railroad Shops

New York Central R. R.
A. T. & S. F. R. R.
Michigan Central R. R.
Pennsylvania R. R.
Union Pacific R. R.
N. Y., N. H. & H. R. R.

Electrical Parts Mfrs.

Westinghouse Lamp Company
Nilco Lamp Works, Inc.
George Cutter Company
Fibroc Insulation Co.
Blizzard Manufacturing Co.

Engineering Schools

Mass. Institute of Technology
Carnegie Institute Technology
Purdue University
Michigan University
Ohio University
Leland Stanford University
Yale University
Illinois University

Glass Manufacturers

Western Glass Co.
Quality Glass Co.
L. E. Smith Co.
Central Glass Works
Schoy Sheet Glass Co.

Truck Fleet Stations

American Railway Express Co.
Springfield Fire Department
The People's Motor Bus Co.
Twin City Rapid Transit Co.
Tompkins Bus Co.

Power & Light Cos.

Penn. Power & Light Co.
Hartford Electric Co.
Kentucky Utilities Co.
Appalachian Power Co.
Illinois Power & Light Corp.

Tool Manufacturers

Champion Shoe Machinery Co.
Elco Tool Corporation
Gustafson-Scott Mfg. Co.
Hanchett-Swage Works
Woodworkers Tool Co.
Ajax Tool & Die Co.

Auto Accessory Mfrs.

McQuay Norris Mfg. Co.
Brown, Lipe & Chapin Co.
Auto Specialties Mfg. Co.
National Standards Co.
Cleveland Piston & Mfg. Co.
Rich Steel Products Co.

Steel Mills

Bethlehem Steel Co.
Inland Steel Co.
U. S. Steel Co.
Youngstown Sheet & Tube Co.
Federated Metal Corp.

Radio Manufacturers

Radio Corp. of America
A. H. Grebe and Co.
The Sparks-Withington Co.
Fansteel Products Co.

Munitions Manufacturers

Colts Fire Arms Mfg. Co.
Union Metallic Cartridge Co.
Remington Arms U. M. Co.
E. I. du Pont de Nemours Co.
Hercules Powder Co.

Oil Companies

Standard Oil Co.
Gulf Refining Co.
Texhoma Oil & Refining Co.
Oklahoma Pipe Line Co.
Prairie Pipe Line Co.

Paper Mills

Whiting Paper Co.
L. L. Brown Paper Co.
Malone Paper Co.
Whiting Plover Paper Co.
Scott Paper Co.
Little Falls Paper Co.

Manufacturing Plants

Chicago Flexible Shaft Co.
Kroehler Mfg. Co.
Federal Bearings Co.
Kirsch Mfg. Co.
Defiance Automatic Screw Co.
Link Belt Co.
Yale & Towne Mfg. Co.
Corbin Cabinet Lock Co.
Weaver Manufacturing Co.
Precision Speedometer Co.
United Shoe Machinery Corp.
Carborundum Co.

Ship Building Companies

Newport News Shipbuilding Co.
Federal Shipbuilding Co.
Bethlehem Ship Building Co.
New York Ship Building Co.

Textile Mills

Amoskeag Textile Mills
Chenango Silk Co.
Southern Mills Corp.
Daniel Boone Knitting Mills
Patchogue-Plymouth Mills

Coal Mines

Lillybrook Coal Co.
Banner Fork Coal Corp.
Island Creek Coal Co.
Peabody Coal Co.
New River Coal Co.

U. S. Government

U. S. Naval Vessels
U. S. Navy Air Service
West Point Military Academy
Smithsonian Institution
U. S. Aviation Corps
U. S. Dept. of Interior
U. S. Coast Guard
U. S. Geodetic Survey

Motor Manufacturers

Western Electric Co.
Westinghouse Electric Mfg. Co.
General Electric Co.
Wagner Electric Mfg. Co.
Baldor Electric Co.

A Partial List of Overseas Users of South Bend Lathes

Guayaquil and Quito Ry., Guayaquil, Ecuador
Motors Supplies, Ltd., Brisbane, Australia
Barbados Foundry Co., Barbados, Br. West Indies
Brenno and Co., Rio de Janeiro, Brazil
Eleazer G. Larrea, Talcahuana, Chile
Peking-Suiyan Railway, Peking, China
Govt. of Antioquia, Medellin, Colombia
Guatemala Plantations, Ltd., Rio Bravo, Guat.
Oficina Tecnica, Tegucigalpa, Honduras
Rangoon Eng. Works, Rangoon, India

Booker Bros.—McConnell, Georgetown, Br. Gui.
Kho Han Suan, Soekaradja, Java
Jamaica Public Service Co., Kingston, Jamaica
Oriental Trading Co., Darien, Manchuria
Mazital Copper Co., Saltillo, Mexico
Enrique Halphen y Cia, David, Panama
Central Aguirre Sugar Co., Jobos, Porto Rico
Dept. of Public Works, Santo Domingo, Dom. Rep.
Atkinson Motor Co., Bloemfontein, South Africa
La Guayra and Caracas Ry. Co., Caracas, Venezuela

The New
"South Bend"
LATHES

