



**INSTRUCTIONS AND REPAIR PARTS**  
**No. 6300 SERIES 12" LATHES**

**ATLAS PRESS COMPANY**  
**KALAMAZOO, MICHIGAN, U. S. A.**



## Do Not Operate The Lathe Until . . .

- it is properly mounted and leveled. Atlas-Clausing lathes pass rigid inspection and operating tests before shipment - to maintain its built-in accuracy it must be properly installed.
- you are acquainted with the lathe and understand all the controls and their functions.
- you have oiled the lathe.
- you have carefully read all the instructions.

Then operate the lathe in back gear - get the "feel" of the controls - set up different threads and feeds - engage the power feeds - get acquainted with the lathe before starting a job - doing that will save time and produce better work.

## INDEX

	Page
Mounting and Leveling.....	3
Lubrication.....	3
Maintenance and Controls.....	4
Setting up for Threads and Feeds.....	6
Repair Parts.....	8
Numerical Parts List.....	16

## INSTRUCTIONS FOR ORDERING REPAIR PARTS

**IMPORTANT:** The following information must be furnished on all repair part orders:

1. Model Number and Serial Number of your lathe. This is found on the plate attached to the bed.
2. Part Number and Name of part.
3. Quantity required.

Parts shown coded are standard parts and should be purchased locally.

*Parts prices will be quoted on request.*

## Instructions For Setting Up The Lathe

The lathe should be very carefully unpacked and installed to retain the fine accuracy that has been built into it. Be sure all the parts are removed before packing material or crate is destroyed. Clean the lathe thoroughly. Wipe all surfaces with a clean cloth and immediately apply a coating of good machine oil to the machined surfaces to prevent rust. Wipe off the oil occasionally and do not allow dust, chips or dirt to accumulate. Cover the lathe when not in use. Cleaning and oiling the finished surfaces regularly will help to retain accuracy and ease of operation.

### MOUNTING AND LEVELING THE LATHE

It is most important that the lathe is mounted on a solid bench or stand which is reasonably level and rests solidly on the floor. A concrete floor or base is the best foundation for supporting lathe bench or stand. A wood floor should be well braced and capable of absorbing any vibration and to safely withstand the load.

The lathe must be accurately leveled. Use only a precision level to level the lathe. The level should be at least 10 to 12 inches long and should show a distinct movement of the bubble when a .003 shim is placed under one end of the level.

Both ends of the lathe bed, the headstock end and the tailstock end should be checked with the level placed at right angle to length of the bed. Place parallel bars or two metal blocks of exact equal thickness on the flat ways. These blocks or bars must be thick enough to clear the V ways when the level is set upon them. By leveling from the flat ways, not the V's, you are assured of leveling in the same manner in which the lathe is checked and inspected at the factory. Place shims of hardwood or metal under the mounting pads of the feet of the lathe until lathe is level. Both bench and cabinet model lathes must be leveled by placing shims under the pads of the lathe bed legs - do not try to level the bed by shimming under the bench or cabinet. If the lathe is not properly leveled, it may twist the lathe bed, resulting in misalignment of the headstock or tailstock with the ways, causing the lathe to chatter, turn and bore taper. ACCURATE WORK CANNOT BE EXPECTED IF THE LATHE IS NOT LEVEL.

Lag screws or bolts can be used to secure bench to a wood floor. When setting the lathe on concrete - mark the location of the bolt holes and use a drill to make a hole large enough to receive expansion bolts or set studs or bolts in melted lead. After bolting the stand or bench to the floor, check the lathe again with the spirit level as the tightening action of the bolts may have pulled down enough to change the level. In time, the stand may settle and it may be necessary to readjust the shims to correct this condition. *Check the level of the lathe at frequent intervals to assure accurate turning.* If lathe turns taper between centers, first check the tailstock center alignment, then, check the level. A bored hole that is not straight is an indication that the lathe is not level.

### OILING THE LATHE

Before operating lathe, the headstock, gear box and carriage apron must be filled with S.A.E. No. 20 machine oil.

Remove headstock cover and plug on front end of headstock. Fill headstock to level of oil plug. Replace plug and cover. When replacing cover, be sure to use screw with breather hole away from bull gear. If this isn't done, the bull gear will throw oil out through the breather hole. Oil level can be checked and refilled by removing the plug.

Remove gear box cover and pour oil through opening, until level with oil cup on side of gear box. The oil cup is at the proper oil level - maintain this oil level at all times.

Fill the two elbow oil cups at the top rear of the headstock. After that, a drop of oil is sufficient for each day of use.

For each day of use, put several drops of oil in the oil cup at the top of the gear guard. This lubricates the gear faces of the gear train.

Fill the oil cup in the spindle drive pulley. After that a drop of oil is sufficient for each day of use. Access to the oiler is through the hole in the gear guard next to the handwheel.

To fill oil reservoir in apron remove one of the screws that hold apron to carriage and use hole for supplying oil. Fill apron to level of oil cup on side of apron. Maintain this oil level at all times.

Other parts to oil occasionally are:

1. Right lead screw bearing

2. Tailstock ram
3. Tailstock screw
4. Carriage handwheel shaft
5. Leadscrew
6. Carriage and compound dovetail ways
7. Lathe bed ways
8. Felt wipers on carriage saddle
9. Rim of threading dial.

**KEEP YOUR LATHE CLEAN** - oil and dirt form an abrasive compound which can easily damage carefully fitted bearing surfaces. Wipe the bed and all polished parts with a clean oily rag at frequent intervals. Use a brush to clean spindle threads, gear teeth, lead screw threads, etc.

**DO NOT OPERATE THE LATHE** - until you are thoroughly familiar with all the controls and their functions (read carefully the instructions MAINTENANCE AND CONTROLS). Then operate the lathe in back gear - get the "feel" of the controls - set up different threads and feeds - engage the power feeds - get acquainted with the lathe before you start a job - it will save time and produce better work.

## Maintenance And Controls

### HEADSTOCK

The headstock on the 6300 series Atlas lathe is completely enclosed and all parts run in a bath of oil.

### FEED REVERSE LEVER

The feed reverse lever, or lead screw direction lever, is located on the front face of the headstock - see Figure 1. Moving this lever to right or left reverses rotation of lead screw. Vertical position of lever is neutral and disengages gear train. This lever should not be moved while lathe is operating at high speeds, but it is possible to quickly reverse lead screw at lower speeds if desired.

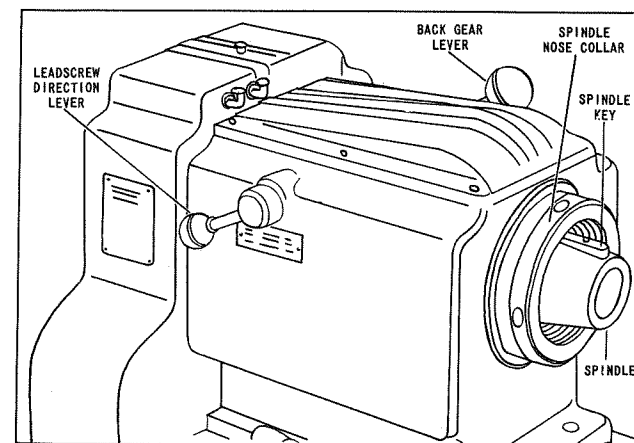

1 Lathe headstock showing location of lead screw direction lever.

### SPINDLE DRIVE, See Figure 2

**Back Gear Drive** - To engage back-gear drive, disengage spindle clutch wheel from driver pulley by sliding wheel in direction away from headstock.

Next, move back-gear lever to the right. If gears will not mesh, rotate spindle.

**Direct Drive** - Disengage back-gear drive by moving back-gear lever to left. Then engage the spindle clutch wheel with the driver pulley by sliding toward headstock, and rotating wheel if necessary.

**CAUTION** - Always stop motor before changing from one drive to the other.

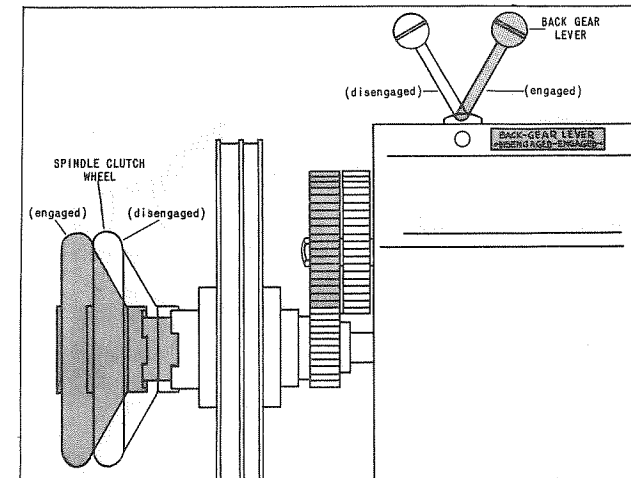

2 Position of back gear lever and clutch wheel for spindle drive in back gear (shaded) and in direct drive (outlined).

### MOUNTING CHUCKS AND FACE PLATES

To remove face plate or chuck, first lock spindle by placing back-gear lever in the back gear engaged position and the handwheel in the "IN" position. (This locks spindle - do not turn on the power). Place the spindle nose collar spanner wrench in one of the six holes on the collar and turn in a clockwise direction until the collar is off the face plate or chuck. Carefully remove chuck or face plate so as not to damage spindle.

To install a chuck or face plate, first make certain there are no chips or dirt on the tapered nose or in the threads of the spindle nose collar. Chips and dirt are liable to score the spindle nose, preventing accurate fitting.

Rotate spindle until key is up - it will be easier to line up key with

keyway in chuck or spindle. Lock spindle in this position. Then mount chuck or face plate on spindle nose, lock in position by screwing on the spindle nose collar. Release spindle. **DO NOT TURN ON POWER WITH THE SPINDLE LOCKED.**

### AUTOMATIC APRON

Figure 3 gives the names and positions of the carriage controls. The carriage handwheel moves the carriage along the lathe bed. The cross feed and compound slide ball cranks move the carriage slide and tool rest in and out.

The carriage lock screw is used to lock the carriage to the bed - use it for facing or cut-off operations only.

The power feed lever controls the operation of both power longitudinal and power feeds - the half-nut lever engages the half-nuts with the lead screw. When one of these levers are engaged, the other is locked and cannot be moved - **DO NOT FORCE**. The position of the levers to obtain a thread or feed are illustrated in Figures 4, 5, and 6. The direction of feed is controlled by the reverse lever on front of headstock.

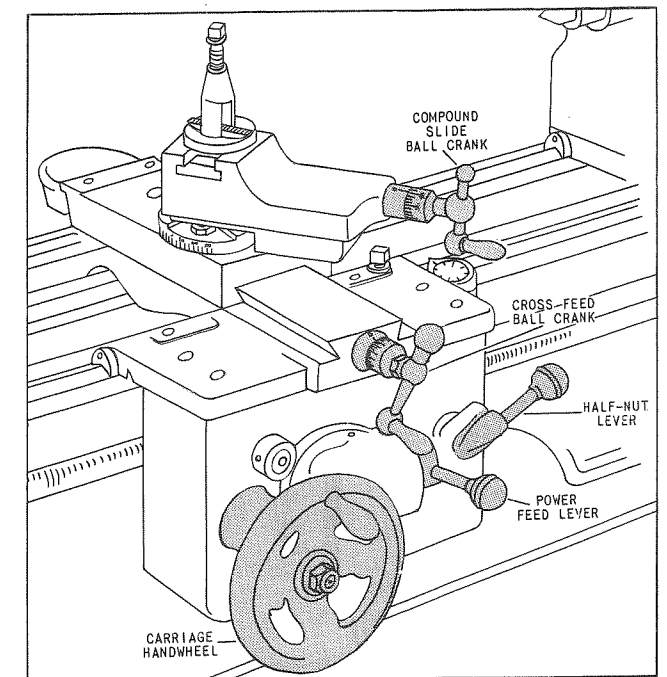

3 Controls on the lathe carriage.

**IMPORTANT** - Use the half-nut lever for threading only - never for feeds. It will prolong the life of the lead screw, and preserve its accuracy for threading operations.

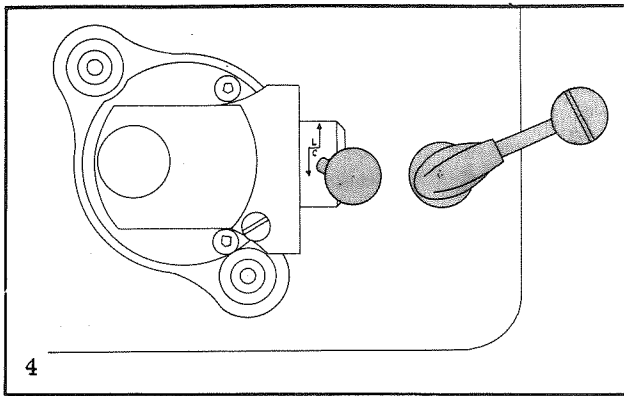

**THREADING** - Place feed lever at the horizontal position. Shift split-nut lever upwards to engage split-nuts with lead screw. Use the split-nuts for threading only - not for feeds.

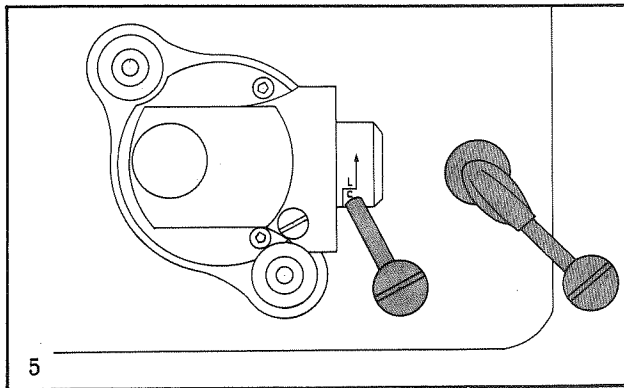

**POWER CROSS FEED** - To engage power cross feed, place split-nut lever in the down position - the feed handle cannot be moved until split-nut lever is in this position. Move feed handle downward to the vertical position.

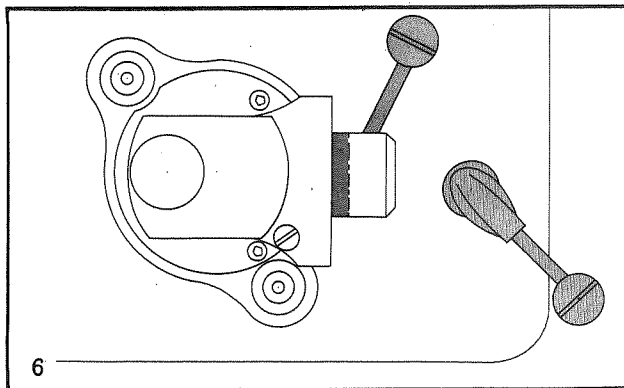

**LONGITUDINAL FEED** - To engage longitudinal feed, first make sure split-nut lever is in the down position. Shift feed lever sideways to the right about 1/4", and then upwards to the vertical position.

The threading dial is used in thread cutting and indicates the proper time to engage the half-nut lever so that the cutting tool will enter the same groove of the thread for each cut.

When cutting even numbered threads engage the half-nut lever at any one of the markings on the threading dial for each cut of the thread. When cutting odd numbered threads, engage the half-nut lever for the first cut and all successive cuts at either the 1 or 2 positions on the dial. When cutting half-numbered threads, engage the half-nut lever at the same mark on the threading dial for each cut of the thread.

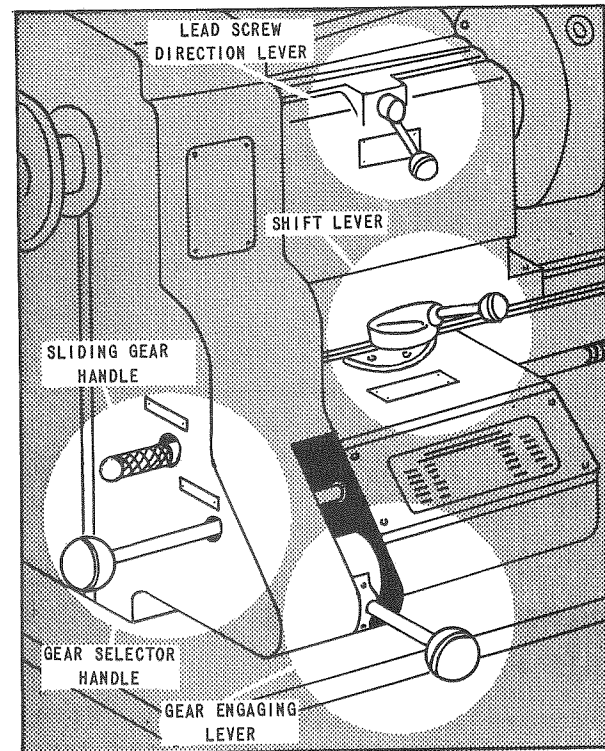

7 Illustration showing the name and location of controls used to obtain a thread or feed.

### SELECTION OF THREADS AND FEEDS

Study the chart on the gear box - it lists the threads and feeds available and indicates the position of the controls for thread or feed desired. Figure 7 illustrates and names these controls.

Sequence of engaging controls for thread or feed are outlined below:

**IMPORTANT** - Before setting up a thread or feed make certain the carriage feed controls are not engaged.

1. Pull gear engaging lever knob out and move lever up as far as it will go. (When this lever is in its lowest position the stack gears are locked in mesh and the gear selection handle cannot be moved).
2. Second, Slide gear selector handle until red marker on gear chart is framed in the position of the thread or feed desired.
3. Move sliding gear handle "in" or "out" as indicated on chart for thread or feed required.
4. Shift lead screw direction lever for the direction of carriage travel.
5. To make sure gears will engage, first start motor and then move gear engaging lever *down* as far as it will go - until it locks in position.
6. Next, check the chart for the position of the shift lever. There are three positions - center, left and right. Shift the lever to position indicated on chart. Make sure lever is properly indexed. (It may take a few seconds for the dog gears to engage if lathe is in back gear or turning slowly). Lathe is now ready to cut the thread or feed.

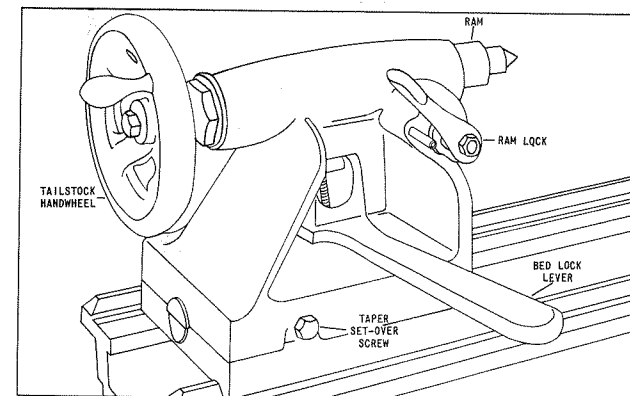

8 Controls on the lathe tailstock.

### TAILSTOCK

Tailstock is securely locked to the bed with the lever-controlled bed lock located on the rear of the tailstock. Graduations on the ram simplify accurate boring and drilling. Ram is locked in place with the lock handle located on top of tailstock. Before inserting the center in the tailstock ram, clean both tapers thoroughly with a dry cloth.

Tailstock can be set over 1" for taper turning, by first loosening the bed clamp and then adjusting the screws on front and back of tailstock base.

### STANDARD DRIVE COUNTERSHAFT

Changing Speeds - Lower belt tension lever to loosen belts from the pulleys. Shift belt to position desired and then raise lever to tension belt. The chart, Figure 9, lists the speeds available and how they are obtained.

Adjusting Spindle Belt - The spindle drive belts may be adjusted by loosening the two screws on the hanger and moving the hanger on the two vertical supporting rods.

Adjusting Motor Belt - Motor belt may be adjusted by moving the collars located beneath the motor base tension springs.

### VARIABLE SPEED DRIVE

Dial control for instant speed changes is located on the VARIDRIVE motor - accessible through cabinet door. (If No. 7581 Remote Control unit is used, speed indicator dial is located on front of cabinet). Provides speeds between 30 and 1400 RPM.

**CAUTION: DO NOT TURN SPEED CONTROL DIAL UNLESS MOTOR IS RUNNING. OPERATE UNIT OVER ENTIRE SPEED RANGE AT LEAST THREE TIMES A WEEK.**

Complete lubricating instructions are shown on plate attached to unit.

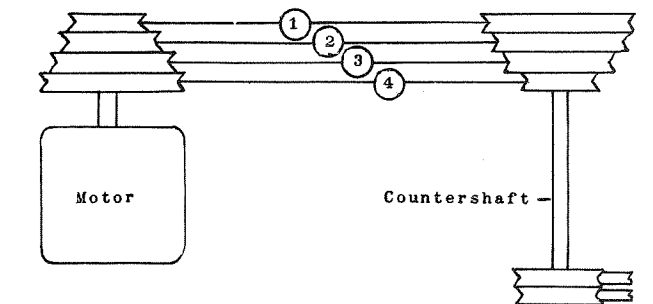

SPINDLE SPEEDS PER RPM							
BACK GEAR DRIVE				DIRECT DRIVE			
BELT POSITIONS				BELT POSITIONS			
1	2	3	4	1	2	3	4
55	88	138	220	324	517	810	1300

9 Spindle Speed Chart











# NUMERICAL PARTS LIST

For No. 6300 SERIES 12-inch LATHES

## ORDERING INFORMATION

Order all parts by PART NUMBER and NAME. Standard parts (coded) beginning on Page 19 should be purchased locally. Parts prices will be furnished on request.

PART NUMBER	DESCRIPTION	PAGE	PART NUMBER	DESCRIPTION	PAGE
<b>9 SERIES</b>					
9-88	No. 2 M.T. Center.....	15	C-325	Back Gear Lever.....	9
<b>10 SERIES</b>					
10-1542	Bushing.....	11	C-326	58T Bull gear.....	9
<b>50 SERIES</b>					
50-18	Bearing.....	11	C-327	Headstock Cover.....	9
<b>C SERIES</b>					
C-281	Shifter Lever.....	9, 11, 14	C-328	Headstock.....	9
C-285	Back Gear Spring.....	9	C-329	Lock Nut.....	9, 10
C-286-S	Drive Gear Assembly.....	9	C-330	Lock Washer.....	9
C-287	Breather Screw.....	9	C-331	Headstock Clamp (Front).	9
C-298	Oil Seal.....	9	C-332	Spring.....	10
C-299	Oil Seal Holder.....	9	C-332A	Compression Spring.....	10
C-300	1/2" Retaining Ring.....	14	C-332B	Compression Spring.....	9, 11
C-300A	3/4" Retaining Ring.....	9, 14	C-334	Bushing.....	10
C-300C	1 11/16" Retaining Ring...	10	C-335-S	Front Spindle Bearing...	9
C-300G	.669" Retaining Ring.....	12	C-336-S	Rear Spindle Bearing....	9
C-300K	5/8" Retaining Ring.....	11	C-338A	Reducer Sleeve (No. 2M.T.)	9
C-302	Back Gear Rack.....	9	C-339	Spindle.....	9
C-304	Reverse Control Gear.....	9	C-340	Back Gear Washer.....	9
C-305	Sliding Yoke.....	9	C-341A	Oil Seat.....	9
C-307	15T Pinion.....	9	C-342	Spindle Nut.....	9
C-308	Sliding Reverse Gear.....	9	C-343	Pin Spanner Wrench.....	9
C-309	Reverse Lever Shaft.....	9	C-344	Drive Pulley.....	10
C-310	Back Gear Shaft.....	9	C-346	Pulley Hub and Gear.....	10
C-310-S	Shaft with Collar.....	9	C-347	Retaining Ring.....	10
C-311	Reverse Lever Hub.....	9	C-347A	Retaining Ring.....	9
C-312	Back Gear Bushing.....	9	C-348	Spindle Key.....	9
C-313	36T Reverse Gear.....	9	C-349	Collar.....	9
C-314	Idler Shaft.....	9	C-350	Oil Seal Ring.....	9
C-315	Gear Shaft.....	9	C-351	Handwheel Key.....	10
C-317	Control Gear.....	9	C-352	Pulley Key.....	10
C-318	Double Reverse Gear.....	9	C-353	Reverse Guide Collar....	9
C-319A	Bushing.....	9	C-354	Reverse Index Bushing...	9
C-320	Bushing.....	9, 14	C-355	Spacer.....	9
C-322	Knob.....	9, 11, 14	C-359-S	Screw w/Ball & Spring...	9
C-324	Knob.....	9, 10, 11	C-361	Nut.....	9
C-324A	Cradle Lock Knob.....	10	C-363A	Oil Cup.....	10, 11, 14
			C-363B	Oil Cup.....	11, 14
			C-364-S	Screw w/Ball & Spring...	14
			C-365	Dog Gear Shaft.....	14
			C-366	48" Rack.....	8
			C-370	Tool Rest Slide.....	13
			C-370-S	Cross Slide Assembly....	13

PART NUMBER	DESCRIPTION	PAGE	PART NUMBER	DESCRIPTION	PAGE
C-371	Thrust Washer.....	10	DL-477	Micrometer Dial.....	13
C-373	Face Plate.....	9	DL-479	Ball Crank Handle.....	13
C-375	Tool Post Ring.....	13	DL-482	Split Bushing.....	13
C-376	Tool Post Clamp.....	13	DL-485	Ball Crank Handle.....	13
C-377	Tool Post.....	13	DL-488	Ball Crank.....	13
C-378	Blocker.....	13	DL-489	Ball Crank.....	13
C-379	Leadscrew, 24".....	8	DL-493	Bushing.....	13
C-380	Leadscrew, 28".....	8	DL-501	Tailstock Base.....	15
C-381	Leadscrew, 48".....	8	DL-502	Off Set Nut.....	15
C-389	Pipe Plug.....	9, 11, 14	DL-510	Wrench.....	15
C-390	Tool Post Screw.....	13	DL-511	Bed Clamp Nut.....	15
C-391	Pipe Plug.....	9	DL-512	Bed Clamp.....	15
C-395	Collar (Purchase C-310S)	9	DL-513	Handwheel.....	14, 15
C-398	Gib.....	13	DL-514	Wrench Nut.....	15
C-401	Spindle Drive Plate.....	10	DL-515	Wrench Pin.....	15
C-402	Back Gear Lever Plate...	9	DL-517	Tailstock.....	15
C-403	Sliding Gear Handle Plate	10	DL-518	Tailstock Bearing.....	15
C-404	Gear Engaging Plate.....	10	DL-520	Spindle Key.....	15
C-405	Gear Selector Plate.....	10	DL-521	Lock Bolt.....	15
C-406	Direction Plate.....	9	DL-522	Spindle Lever.....	15
C-407	Shift Lever Plate.....	11	DL-523	Tailstock Spindle.....	15
C-924	Lathe Bed, 24".....	8	DL-524	Collar.....	15
C-936	Lathe Bed, 36".....	8	DL-525	Tailstock Screw.....	15
C-948	Lathe Bed, 48".....	8	DL-525-S	Screw w/Collar.....	15
<b>DL SERIES</b>					
DL-102	36" Rack.....	8	DL-526	Lock Sleeve.....	15
DL-106	24" Rack.....	8	DL-527	Lock Sleeve.....	15
DL-107	Bed Leg.....	8	DL-528	Clamp Bolt.....	15
DL-210	Headstock Clamp (Rear)..	9	DL-529	Off Set Bolt.....	15
DL-212	Countershaft Pulley Key.	12	DL-530	Tapered Key.....	15
DL-240	Expansion Plug.....	11	DL-551	Tool Post Wrench.....	13
DL-259	Countershaft Collar.....	12	DL-552	Compound Wrench.....	13
DL-295	Bushing.....	9	DL-585	32T Gear.....	11
DL-341	Carriage Lock Bolt.....	13	DL-625	Thread Dial Body.....	14
DL-355	Leadscrew Bracket.....	8	DL-628	Thread Dial Gear.....	14
DL-405	Handwheel Handle.....	14, 15	DL-630S	Thread Dial.....	14
DL-421	Spring Lock Washer.....	14	DL-666	1/4" Steel Ball.....	10, 11
DL-426	Split Nut Gib.....	14	DL-698	Felt Washer.....	11
DL-431	Felt Wiper Clip.....	13, 15	DL-728	Rear Apron.....	13
DL-432	Felt Wiper.....	13, 15	<b>M6 SERIES</b>		
DL-433	Felt Wiper Clip.....	13, 15	M6-72	Dust Cover.....	11
DL-434	Felt Wiper.....	13, 15	<b>O SERIES</b>		
DL-438	Scroll.....	14	O-248	Rubber Cushion.....	12
DL-451	Front Gib.....	13	O-250	Countershaft Hanger....	12
DL-453	Cross Slide Screw Nut...	13	O-251	Drive Mount Bar.....	12
DL-454	Special Cap Screw.....	13	O-253	Motor Base.....	12
DL-455	Rear Gib.....	13	O-254	Cross Tie.....	12
DL-457	Cross Slide Gib.....	13	O-255	Motor Mount Block.....	12
DL-458	Cross Slide.....	13	O-256	Mount Bar.....	12
DL-458-S	Compound Assembly.....	13	O-257	Motor Lift Link.....	12
DL-459	Cross Slide Swivel Post.	13	O-261	4 Step Pulley 1/2" Bore..	12
DL-460	Compound Swivel.....	13	O-261A	4 Step Pulley 5/8" Bore..	12
DL-471	Compound Slide Nut.....	13	O-261B	4 Step Pulley 3/4" Bore..	12
DL-473	Compound Screw.....	13	O-263	Belt, Standard Drive....	10
DL-475	Compound Bolt.....	13	O-263A	Belt, Variable Drive....	10
			O-264	V Belt, 1/2" x 36".....	12

PART NUMBER	DESCRIPTION	PAGE	PART NUMBER	DESCRIPTION	PAGE
0-265	Countershaft Pulley.....	12	0Q-103	Collar.....	10
0-266	Countershaft Knob.....	12	0Q-104	Thrust Washer.....	10
0-267	Countershaft Bearing.....	12	0Q-105	Spindle Engage Wheel.....	10
0-269	Cross Tie Bar.....	12	0Q-106	Gear Stud.....	10
0-270	Countershaft Key.....	12	0Q-107	Gear Stud.....	10
0-271	Countershaft.....	12	0Q-108	Sleeve.....	10
0-276	Mount Spring.....	12	0Q-108A	Gear Stud Sleeve.....	10
0-278	Oiler Bushing.....	10	0Q-109	35T Drive Gear.....	10
0-279	Mount Bar Brace.....	12	0Q-110	40T Idler Gear.....	10
<b>OQ SERIES</b>					
0Q-1	Gear Box.....	11	0Q-111	Quadrant Nut.....	10
0Q-2	Dog Gear Shaft.....	11	0Q-115	Gear Guard Back Strap....	10
0Q-3	Drive Shaft.....	10, 11	0Q-116	Dot Fastener.....	10
0Q-4	Selector Pinion.....	10, 11	0Q-118	Oil Line.....	10
0Q-5	Shaft.....	11	0Q-118A	Oil Line.....	10
0Q-6	Selector Shaft.....	11	0Q-197	Gear Guard (Back).....	10
0Q-7	Bushing.....	11	0Q-198	Gear Guard.....	10
0Q-8	Sliding Dog Gear.....	11	0Q-200	Selector Fork.....	11
0Q-9	24T Dog Gear.....	11	0Q-207	Selector Gear.....	11
0Q-10	Dog Gear Shaft Washer....	11	0Q-212	Selector Handle.....	10, 11
0Q-11	Bushing.....	11	0Q-214	Cradle Pinion Gear.....	11
0Q-12	Washer.....	11	0Q-217	Lever Bracket.....	11
0Q-14	Drive Gear.....	10	0Q-217A	Lever Bracket.....	14
0Q-15	Bushing.....	11	0Q-220	Bearing Cover.....	11
0Q-16	Bushing.....	10, 11	0Q-230	Sliding Gear Key.....	10
0Q-17	Washer.....	11	0Q-231	Dowel Pin.....	14
0Q-18	Sleeve.....	11	0Q-234	Snap Ring.....	11
0Q-24	Over Riding Clutch.....	10	0Q-244	Sliding Gear & Handle....	10
0Q-25	Clutch Lock.....	10	0Q-245C	Lever Base.....	11
0Q-26	Spring Hook.....	10	0Q-246	Selector Gear Bushing....	11
0Q-27	Spring.....	10	0Q-247	Thread and Feed Chart....	11
0Q-29	Cover.....	10	0Q-248	Stud.....	11
0Q-30	Cradle Lock Handle.....	10	0Q-258	Thread Chart Gasket.....	11
0Q-31	Plunger.....	10	0Q-259	Thread Chart Spring Clip.	11
0Q-32	Cap.....	10	<b>Q SERIES</b>		
0Q-33	Washer.....	10	Q-281-S	Lever with Collar.....	12
0Q-34	Compression Spring.....	10	Q-294	Lock Arm Shaft.....	14
0Q-35	Bushing.....	11	Q-295	Gasket.....	14
0Q-38	Cradle Lift Shaft.....	11	Q-296	Cover Plate.....	14
0Q-50	Cradle Lock Lollar.....	10	Q-299	Apron.....	14
0Q-51	Anchor.....	10	Q-301	Idler Gear.....	14
0Q-52	Spacer.....	11	Q-302	Idler Gear Shaft.....	14
0Q-54	Shaft.....	11	Q-309	Rack Pinion.....	14
0Q-55	Shaft Arm.....	11	Q-310	Handwheel Shaft Pinion...	14
0Q-56	Shift Block Stud.....	11	Q-312	44T Pinion Gear.....	14
0Q-57	Shift Block.....	11	Q-313	Sliding Lock Arm.....	14
0Q-58	Gear Box Cover.....	11	Q-314	50T Dog Gear.....	14
0Q-60	Slide.....	11	Q-316	Scroll Shaft Cam.....	14
0Q-61	Shaft and Gear.....	11	Q-328	Scroll Shaft.....	14
0Q-62	Cone Gear Bearing Spacer.	11	Q-329	Collar.....	14
0Q-63	Bushing.....	11	Q-330	50T Sliding Gear.....	14
0Q-65	Cradle.....	11	Q-334	20T Dog Gear.....	14
0Q-69-S	Drive Shaft Bearing.....	11	Q-335	Lock Arm Spring.....	14
0Q-100	Quadrant.....	10	Q-341	Feed Control Sleeve.....	14
0Q-101	Gear Train Bracket.....	10	Q-343	18T Pinion.....	14
			Q-344	Feed Control Index.....	14
			Q-347A	Bearing.....	14

PART NUMBER	DESCRIPTION	PAGE	PART NUMBER	DESCRIPTION	PAGE
Q-348A	Dog Gear Bushing.....	14	Q-417	23T Gear.....	11
Q-349	Pin.....	14	Q-418	24T Gear.....	11
Q-350	Carriage Saddle.....	13	Q-419	26T Gear.....	11
Q-350-S	Saddle Assembly.....	13	Q-420	28T Gear.....	11
Q-351	14T Cross Slide Gear.....	13	Q-441	Cone Gear Shaft Key.....	11
Q-351-S	Cross Slide Screw w/Gear.	13	Q-455	Index Spring.....	10
Q-352	Cross Slide Screw ...	13	Q-456	Steel Ball.....	10, 11
Q-353	Bushing.....	13	Q-465	Dog Gear Bushing.....	11
Q-370	Feed Control Housing.....	14	Q-466	32T Dog Clutch Gear.....	11
Q-375	Expansion Plug.....	14	Q-523	Gear Nut.....	10
Q-380	Thrust Washer.....	14	Q-525	18T Gear.....	9
Q-382	Thrust Washer.....	14	Q-528	60T Gear.....	10
Q-383	Thrust Washer.....	14	Q-540-S	30-72T Gear.....	10
Q-384	28T Worm Gear.....	14	<b>S7 SERIES</b>		
Q-385	Dog Gear Stop.....	14	S7-181	Washer.....	15
Q-387	Expansion Plug.....	11, 14	<b>SR SERIES</b>		
Q-390	Leadscrew Worm.....	14	SR-39	Bushing.....	11
Q-391-S	Key with Pin.....	14	<b>W SERIES</b>		
Q-392	Bushing.....	14	W44-2	Allen Wrench, 1/4".....	13
Q-395	Split Nut (Pair).....	14	W44-3	Allen Wrench, 5/16".....	13
Q-396	Split Nut Gib Shim.....	14			
Q-414	18T Gear.....	11			
Q-415	20T Gear.....	11			
Q-416	22T Gear.....	11			

**STANDARD PARTS**

CODE NO.	DESCRIPTION	CODE No.	DESCRIPTION
1	5/16" -18 x 3/4" Hex Cap Screw	30	1/4" -20 x 3/4" Hdless Set Screw
2	5/16" -18 x 1 1/4" Hex Cap Screw	31	5/16" -18 x 1/2" Hdless Set Screw
3	5/16" -18 x 1 1/2" Hex Cap Screw	32	3/8" -16 x 1 1/4" Sq.Hd.Set Screw
4	3/8" -16 x 1 1/4" Hex Cap Screw	33	1/4" -20 x 1/4" Allen Set Screw
5	3/8" -16 x 1 3/4" Hex Cap Screw	34	1/4" -20 x 5/16" Allen Set Screw
6	1/2" -13 x 1 3/4" Hex Cap Screw	35	1/4" -20 x 1 5/16" Allen Set Scr.
7	1/2" -13 x 2" Hex Cap Screw	36	5/16" -18 x 1/4" Allen Set Screw
8	No. 10-32 x 3/8" Allen Cap Screw	37	5/16" -18 x 5/16" Allen Set Screw
9	No. 10-24 x 1/2" Allen Cap Screw	38	5/16" -18 x 3/8" Allen Set Screw
10	1/4" -20 x 7/16" Allen Cap Screw	39	5/16" -18 x 1/2" Allen Set Screw
11	1/4" -20 x 3/4" Allen Cap Screw	40	3/8" -16 x 1/2" Allen Set Screw
12	5/16" -18 x 3/4" Allen Cap Screw	41	No.2 x 3/16 Parker-Kalon Dr.Scr.
13	5/16" -18 x 7/8" Allen Cap Screw	43	5/16" -18 Hex Nuts
14	5/16" -18 x 1" Allen Cap Screw	44	3/8" -16 Hex Nuts
15	5/16" -18 x 1 1/4" Allen Cap Screw	45	3/8" -24 Hex Nuts
16	3/8" -16 x 3/4" Allen Cap Screw	46	1/4" -20 Jam Nut
17	3/8" -16 x 1" Allen Cap Screw	47	5/16" -18 Jam Nut
18	3/8" -16 x 1 5/8" Allen Cap Screw	48	7/16" -14 Jam Nut
19	5/16" -18 x 7/8" Fill. Cap Screw	49	3/8" -24 Jam Nut
20	No.8 - 32 x 1/2" Rd.Hd.Mach.Screw	50	1/2" -13 Jam Nut
21	No.10 - 24 x 1/2" Fill.Hd.Mach.Scr.	51	1/2" -20 Jam Nut
24	No.10 -24 x 1/2" Flat Hd.Mach.Screw	52	5/8" -18 Jam Nut
25	1/4" -20 x 1/2" Flat Hd.Mach.Screw	53	5/16" -18 Sq. Nuts
27	5/16" -18 x 1 1/4" Carriage Bolt	54	5/16" - Plain Washers
28	No. 10-24 x 3/16" Hdless Set Scr.	55	5/16" - Lock Washers
29	1/4" -20 x 1/2" Hdless Set Screw	56	3/8" - Plain Washers

CODE NO.	DESCRIPTION	CODE NO.	DESCRIPTION
57	3/8" - Lock Washers	69	1/4" x 3/4" Groov Pins, T-2
58	1/2" - Plain Washers	70	1/4" x 7/8" Groov Pins, T-1
59	5/8" - Lock Washers	71	1/4" x 1 1/4" Groov Pins, T-1
60	3/32" x 3/4" Cotter Pin	72	1/4" x 1 1/2" Groov Pins
61	1/8" x 3/8" Groov Pins, T-1	73	3/8" x 3/4" Groov Pins, T-4
63	1/8" x 1/2" Groov Pins, T-4	75	1/8" x 1/2" Roll Pin
64	1/8" x 1/2" Groov Pins, T-6	76	1/4" x 1 1/2" Roll Pin
65	1/8" x 3/4" Groov Pins, T-5	77	1/4" x 1 3/4" Roll Pin
67	1/8" x 1" Groov Pins, T-1	78	No.3 (1/8 x 1/2 ) Woodruff Key
68	3/16" x 5/8" Groov Pins, T-1	79	No.61 (3/16 x 5/8 ) Woodruff Key