

CLAUSING

20"

heavy duty

DRILL PRESSES

SEE YOUR DEALER

WHITE STAR MACHINERY & SUPPLY CO., INC.
720 East 10th
WICHITA, KANSAS

CLAUSING

20" drill presses
PRODUCTION rated
7/8" in steel —
1-1/8" in cast iron

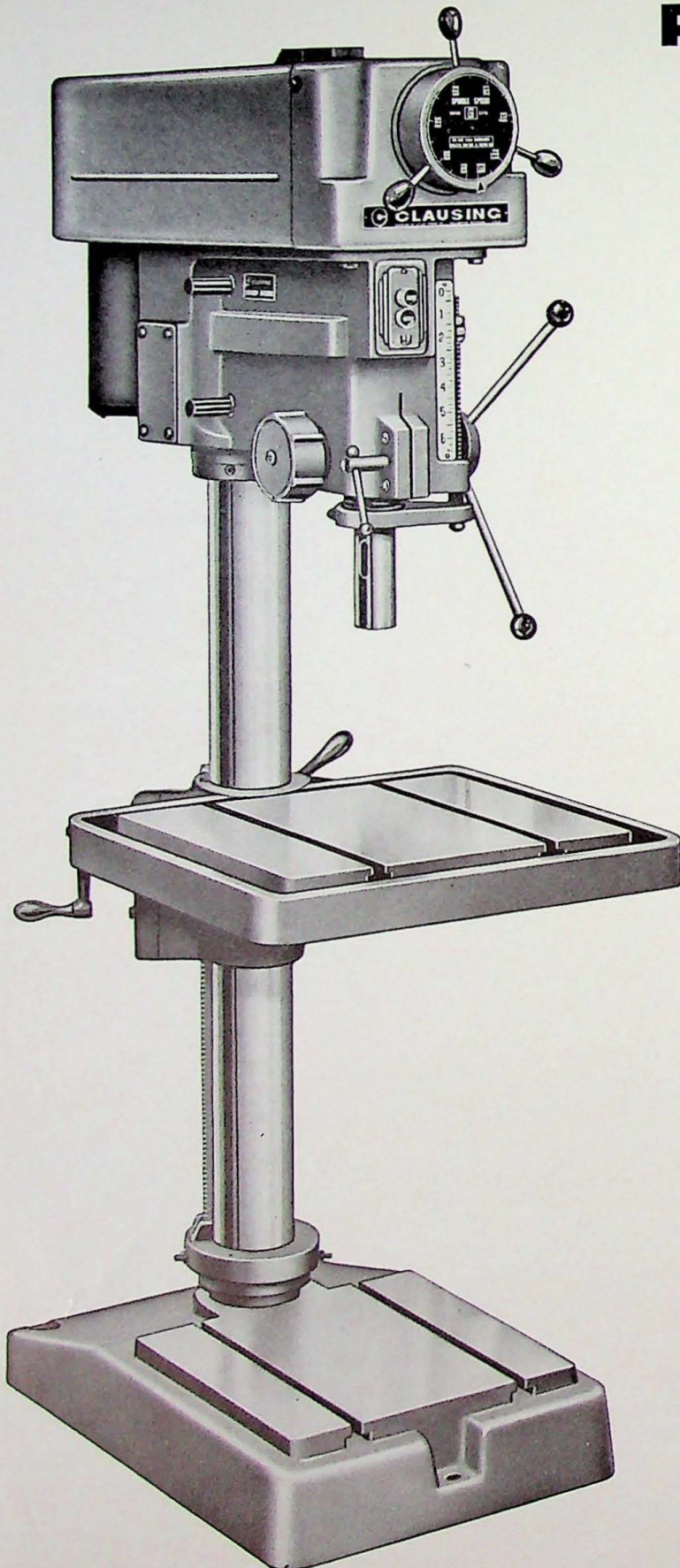

HEAVY-DUTY COUNTERSHAFT DRIVES:

positive-power *variable* speed

or

step pulley models with 5 or 10 speeds

SPEED RANGES from 150 to 2000 RPM

No. 3 MT SPINDLE with 6 1/2-inch TRAVEL
— gear driven power feed, or hand feed.

19 1/2" x 22" PRECISION GROUND TABLE
— elevating mechanism furnished.

4-inch GROUND STEEL COLUMN, 1/2-inch
THICK WALL — greater rigidity, accuracy.

HEAVY BASE, with GROUND surface, T-
slots. Handles big jobs easily, accurately.

READY-TO-RUN — motor and switch in-
stalled, wired, factory tested.

Clausing heavy-duty drills out-perform —
on continuous production, in the tool room,
maintenance shop — every application —
because of their superior design and con-
struction. A demonstration will convince
you — see your Clausing dealer.

Clausing heavy-duty drills deliver superior on-the-job performance, because they are built to perform better. Here are features of their outstanding design and construction.

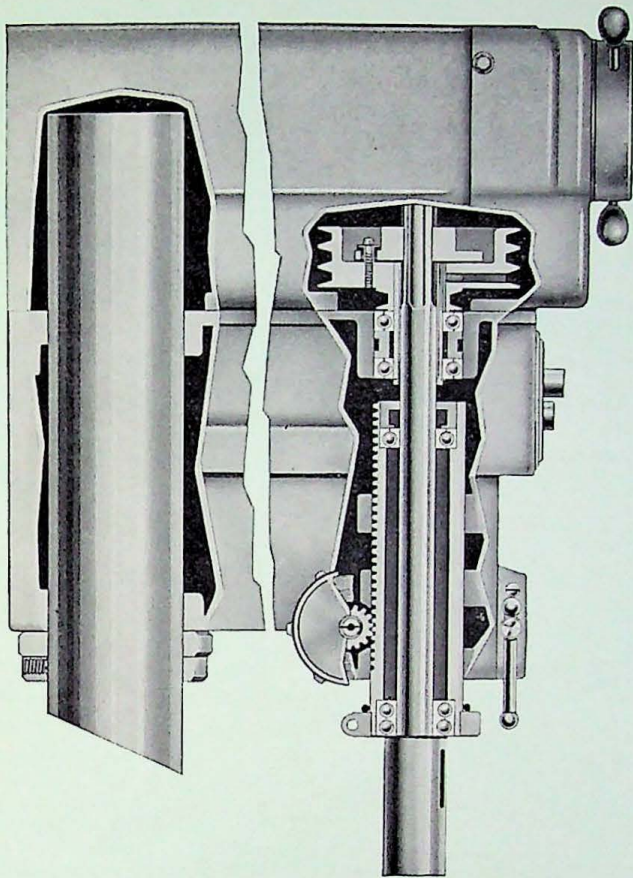

HEAVY-DUTY PRECISION HEAD

Basic to Clausing's superior accuracy — all bearing surfaces in head are precision bored *simultaneously* for exact alignments.

Note the wide spacing of the ball bearings supporting the drive and quill assemblies. Double-row spindle bearing absorbs *both* radial and thrust loads.

Note, too, the three, long bearing surfaces supporting the ground steel quill. Quill return spring adjusts for sensitive drilling or lifting heavy tools. Quill is locked in position by slip-thru handle turning in steel insert.

Depth stop is accurate, easy to set — merely position to depth desired and lock in place. Has .005" graduations for micrometer setting.

Lasting accuracy is assured by split head design with take-up adjustment.

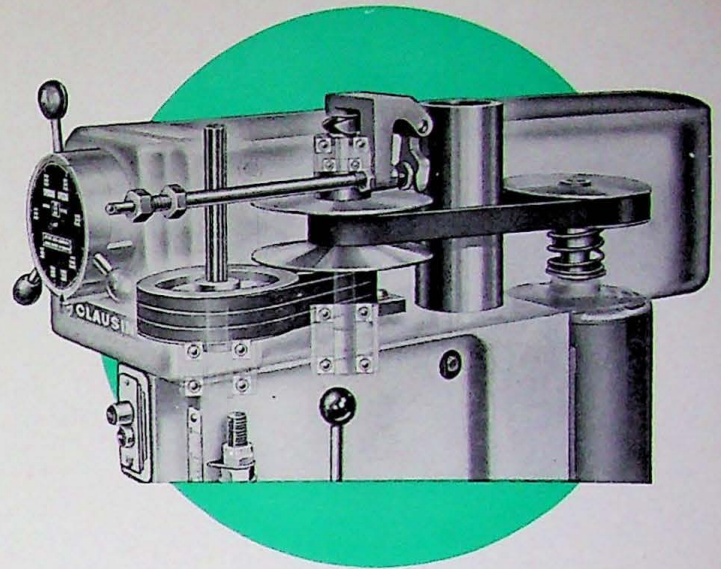

DIAL SPEEDS — RANGES, 150-2000 RPM — with VARIABLE SPEED COUNTERSHAFT DRIVE

Just turn the dial while drill is running to select instantly the best RPM for the job.

Heavy-duty drive is built to deliver full power to the spindle at all speeds:

- three V-belts and cog belt transmit positive-power to spindle
- variable speed and spindle drive pulleys are cast iron, fully machined and balanced
- and there are *eight* lubricated-for-life bearings for smooth performance.

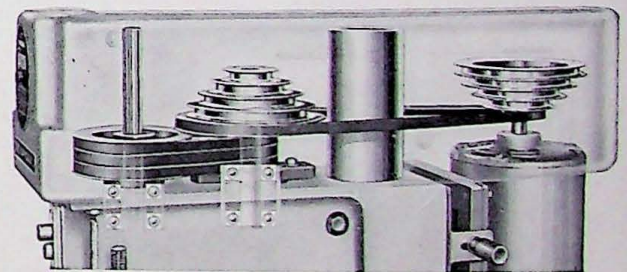

STEP PULLEY COUNTERSHAFT DRIVE — RANGES, 150-2000 RPM

Three speed ranges are available:

- 150 to 2000 RPM, ten speeds
- 200 to 1300 RPM, five speeds
- 300 to 2000 RPM, five speeds

Speed changes are easy with the hinged motor base — chart indicates belt positions.

The Clausing countershaft has *three* V-belts driving the spindle for maximum power.

Fully-machined balanced pulleys, and *six* lubricated-for-life ball bearings assure optimum smoothness.

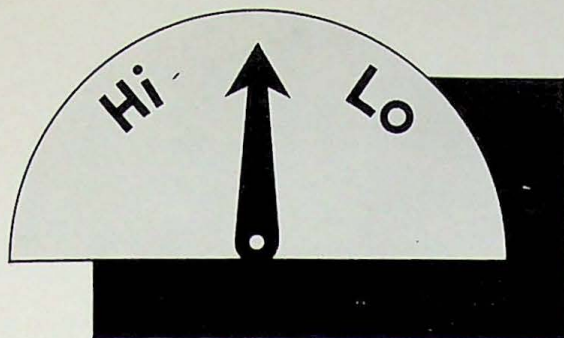

CLAUSING Hi-Lo DRILLS

Dual Speed Range — Double Versatility

A Clausing Hi-Lo Drill handles the work of *two* machines. A turn of the switch provides a low range of speeds from 150 RPM or high speeds to 2000 RPM — ideal for tool room, maintenance and production applications requiring quick-change tooling.

Hi-Lo Drills listed below are equipped with 1800/900 RPM two-speed motors and controls:

Variable Speed Models	Step Pulley Models
No. 2276 (220 V)	No. 2226 (220 V)
No. 2277 (440 V)	No. 2227 (440 V)
Speeds, RPM	Speeds, RPM
Infinite between 150 to 1000 and 300 to 2000	150, 250, 400, 600, 1000 300, 500, 800, 1200, 2000

PRODUCTION OIL TABLE

Outside edges and center section are ground, providing a 19½" x 22" support for easy handling of big work, fixtures. The 15½" x 18" center section has two T-slots, spaced 9" apart. Drain channel has outlet hole with threaded plug. Column bracket, cast integrally with table, has lever-controlled lock.

TABLE POSITIONING MECHANISM

Table positioning mechanism, furnished, provides 20" travel at one setting. Ball race permits easy horizontal positioning of table and work — or swinging table out of way for mounting work on base.

GROUND STEEL COLUMN

Column is ground steel, 4-inch diameter, with ½-inch thick wall — a rigid support that maintains accurate alignments under all loads.

LARGE, HEAVY BASE

Base is a solid foundation for the machine — has 13" x 15½" ground working surface for accurate handling of large jobs . . . two parallel T-slots.

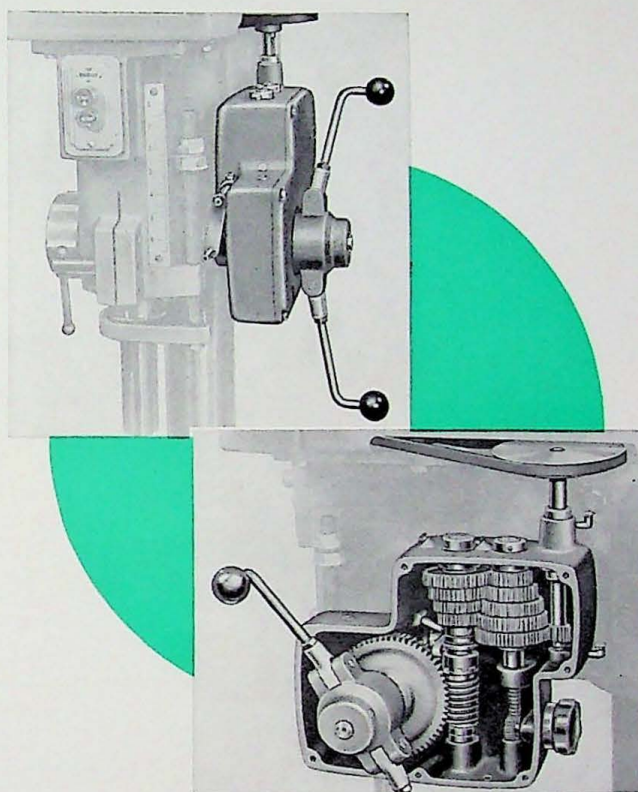

GEAR DRIVEN POWER FEED ATTACHMENT

Positive Gear Drive. As you'll note in illustration, power is developed thru a positive gear drive for maximum efficiency — feed is always in direct relation to drill speed. Friction clutch protects mechanism against overload.

Dial Feed Selection. Just turn dial for feeds of .004", .006", .009", .012". Has neutral position for hand feeds.

Convenient Operation. Moving either handle engages power feed instantly — feed disengages automatically at pre-set depth.

Heavy-Duty Construction. Steel drive gears, ground steel shafts, hardened worm and clutch, anti-friction bearings. Worm and Tobin bronze worm gear run in oil.

When ordered with drill from factory, Power Feed Attachment is installed.

No. 2215 POWER FEED ATTACHMENT, 50 lbs.

SPECIFICATIONS

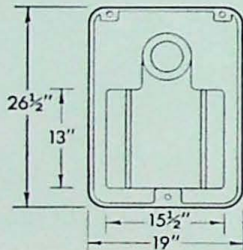
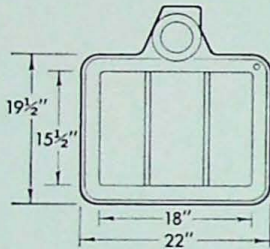
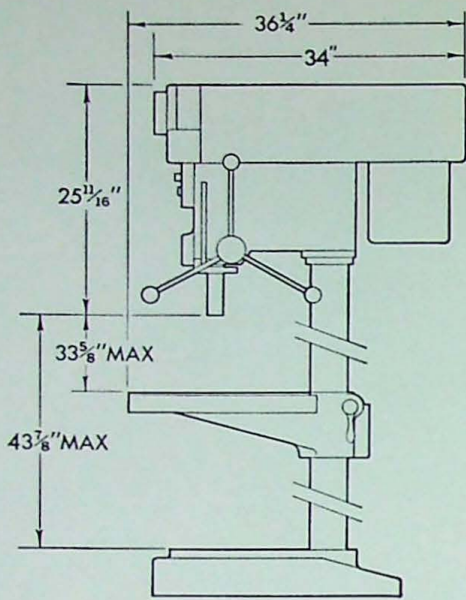

Capacity with 1 1/2 HP motor 7/8" in steel, 1 1/8" in cast iron
 Drill to center of circle 20" dia.
 Spindle nose No. 3 Morse Taper, 1.740" OD
 Spindle travel 6 1/2"
 Column Ground steel, 4" dia., 1/2" thick wall
 Quill Ground steel, 2 1/2" dia.
 Table, overall 19 1/2" x 22"
 Table slots two, 15 1/2" long, for 1/2" T-bolts
 Table travel, one setting 20"
 Spindle to table, maximum distance 33 5/8"
 Spindle to base, maximum distance 43 7/8"
 Base working surface 13" x 15 1/2"
 Base T-slots two, 13" long, for 1/2" T-bolts
 Motor NEMA Frame Sizes 182 and 184
 Shipping weights:
 Variable speed, with motor 640 lbs.
 Step pulley, with motor 600 lbs.

Variable drive:

w/1800/900 rpm two-speed motor 150-1000 and 300-2000 rpm
 w/1140 rpm motor 200-1300 rpm
 w/1725 rpm motor 300-2000 rpm

Step pulley drive:

w/1800/900 rpm two-speed motor... 150, 250, 400, 600, 1000
 and 300, 500, 800, 1200, 2000 rpm
 w/1140 rpm motor 200, 300, 500, 800, 1300 rpm
 w/1725 rpm motor 300, 500, 800, 1200, 2000 rpm

variable-speed drills

MODEL No.	speed range	MOTOR FURNISHED				
		hp	phase	volt	cycle	rpm
2271	300-2000	1	1	115/230	60	1725
2272	300-2000	1 1/2	1	115/230	60	1725
2278	200-1300	1	1	115/230	60	1140
2273	300-2000	1	3	208/220/440	60*	1725
2274	300-2000	1 1/2	3	208/220/440	60*	1725
2275	200-1300	1 1/2	3	208/220/440	60	1140
2276	150-2000	1 1/2-3/4**	3	220	60	1800/900**
2277	150-2000	1 1/2-3/4**	3	440	60	1800/900**

step pulley drills

2221	300-2000	1	1	115/230	60	1725
2222	300-2000	1 1/2	1	115/230	60	1725
2228	200-1300	1	1	115/230	60	1140
2223	300-2000	1	3	208/220/440	60*	1725
2224	300-2000	1 1/2	3	208/220/440	60*	1725
2225	200-1300	1 1/2	3	208/220/440	60	1140
2226	150-2000	1 1/2-3/4**	3	220	60	1800/900**
2227	150-2000	1 1/2-3/4**	3	440	60	1800/900**

2220 Less Motor (Switch furnished for 1 or 3 phase).

All motors are ball bearing equipped.

FURNISHED, ALL MODELS:

variable or step pulley counter-shaft drive; No. 3 MT spindle; oil table; table elevating mechanism; push-button switch or two-speed switch; belt guard; column collar.

READY-TO-RUN MODELS:

motors and switches are installed and wired, ready to connect to current. Single phase motors have 10' cord and plug.

CLAUSING Hi-Lo DRILLS

Dual Speed Range

Double Versatility

Ideal for tool room, maintenance, and production applications with quick-change tools. Variable Drive Models Nos. 2276, 2277 and Step Pulley Models Nos. 2226 and 2227 are equipped with two-speed motors providing an unusually wide range of speeds from 150 to 1000 and 300 to 2000 RPM — two machines at the price of one.

* Operate on 50 cycle at 1425 RPM.
 **Two-speed motors.

Single phase motors are capacitor-start.

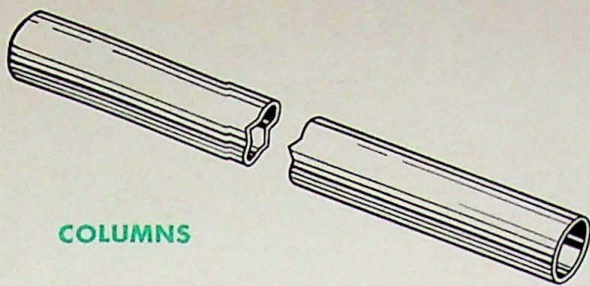

COLUMNS

No. 2293 COLUMN. 43" x 4" x 1/2" wall. 78 lbs.

No. 2294 COLUMN. 66" x 4" x 1/2" wall. 121 lbs.

COLUMN MOUNTING FLANGE

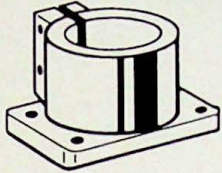

No. 2295 COLUMN MOUNTING FLANGE. 7 1/4" x 5 1/2" x 6" high. Has 4 holes for 1/2" bolts. 30 lbs.

HEAD POSITIONING MECHANISM

Positions head quickly, easily. Maximum travel at one setting, 10". Ball race in support collar permits swiveling head.

No. 2216. POSITIONING MECHANISM. 16 lbs.

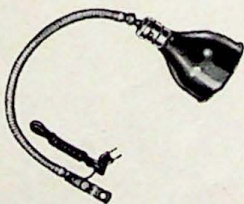
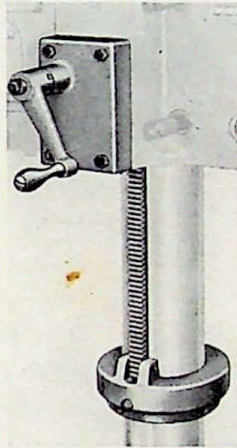

LAMP

No. 1238. Has flexible cable, 6' rubber cord and plug, push-through switch, mounting bracket. 2 lbs.

DRILL CHUCK

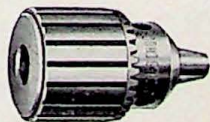

Adapted to No. 3 MT spindles with No. 1898 arbor, below.

No. 1897 Key-Type CHUCK, capacity 3/16" drill to 3/4". 3 1/2 lbs.

ARBOR



No. 1898 ARBOR to adapt No. 1897 chuck to No. 3 Morse Taper drill press spindle. 13 oz.

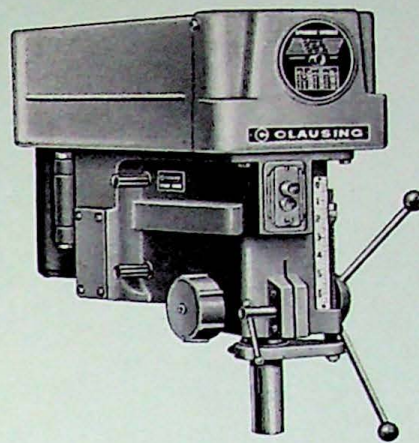

20" drill press heads

Modernize old equipment . . . build special machines . . . at low cost . . . with Clausing drill heads. The opportunities for increasing production and efficiency with these big-capacity heavy-duty units are unlimited.

SPECIFICATIONS

Drilling capacity, with 1/2 HP motor 7/8" in steel, 1 1/8" in cast iron
 Drill to center of circle 20"
 Quill diameter 2 1/2"
 Shipping weights:
 Variable speed models 355 lbs.
 Step pulley models 315 lbs.

Speeds, Variable speed drive:
 w/1800/900 rpm 2-speed motor 150-1000 and 300-2000 rpm
 w/1140 rpm motor 200-1300 rpm
 w/1725 rpm motor 300-2000 rpm

Speeds, Step pulley drive:
 w/1800/900 rpm 2-speed motor 150-1000 and 300-2000 rpm
 w/1140 rpm motor 200-1300 rpm
 w/1725 rpm motor 300-2000 rpm

FURNISHED, ALL MODELS: variable or step pulley countershaft drive; No. 3 MT spindle; push button switch or two-speed switch; belt guard.

MOTORS, where furnished, are installed, wired to switch, ready to connect to current. Single phase motors have 10' cord and plug.

variable-speed drill heads

MODEL NO.	MOTOR FURNISHED				
	hp	phase	volt	cycle	rpm
2281	1	1	115/230	60	1725
2282	1 1/2	1	115/230	60	1725
2288	1	1	115/230	60	1140
2283	1	3	208/220/440	60*	1725
2284	1 1/2	3	208/220/440	60*	1725
2285	1 1/2	3	208/220/440	60	1140
2286	1 1/2-3/4**	3	220	60	1800/900**
2287	1 1/2-3/4**	3	440	60	1800/900**

step pulley drill heads

2231	1	1	115/230	60	1725
2232	1 1/2	1	115/230	60	1725
2238	1	1	115/230	60	1140
2233	1	3	208/220/440	60*	1725
2234	1 1/2	3	208/220/440	60*	1725
2235	1 1/2	3	208/220/440	60	1140
2236	1 1/2-3/4**	3	220	60	1800/900**
2237	1 1/2-3/4**	3	440	60	1800/900**
2230	Less Motor (Switch furnished for 1 or 3 phase).				

All motors are ball bearing equipped.

*Operate on 50 cycle at 1425 RPM

**Two-speed motors.

CLAUSING DIV., ATLAS PRESS COMPANY, KALAMAZOO, MICH.

printed in U.S.A.

561M75C