

OPERATING INSTRUCTIONS AND PARTS LIST FOR CRAFTSMAN LATHE

12 INCH SWING, 36 INCHES BETWEEN CENTERS

MODEL NUMBER 113.23881

The model number of your Lathe will be found stamped on the back of the Headstock cover. Always mention this model number when communicating with us regarding your Lathe or when ordering parts.

HOW TO ORDER REPAIR PARTS

All parts listed herein may be ordered through SEARS, ROEBUCK AND CO. or SIMPSONS-SEARS LIMITED. When ordering parts by mail from the mail order house which serves the territory in which you live, selling prices will be furnished on request or parts will be shipped at prevailing prices and you will be billed accordingly.

WHEN ORDERING REPAIR PARTS, ALWAYS GIVE THE FOLLOWING INFORMATION AS SHOWN IN THIS LIST:

1. The PART NUMBER.
2. The PART NAME.
3. The MODEL NUMBER - 113.23881
4. The NAME of item - LATHE.

COAST TO COAST NATION-WIDE SERVICE FROM SEARS FOR YOUR CRAFTSMAN POWER TOOLS



SEARS, ROEBUCK AND CO. and SIMPSONS-SEARS LIMITED in Canada back up your investment with quick, expert mechanical service and genuine CRAFTSMAN replacement parts.

If and when you need repairs or service, call on us to protect your investment in this fine piece of equipment.

SEARS, ROEBUCK AND CO. - U.S.A.
IN CANADA, SIMPSONS-SEARS LIMITED

OPERATING INSTRUCTIONS AND PARTS LIST FOR LATHE

MODEL NUMBER 113.23881

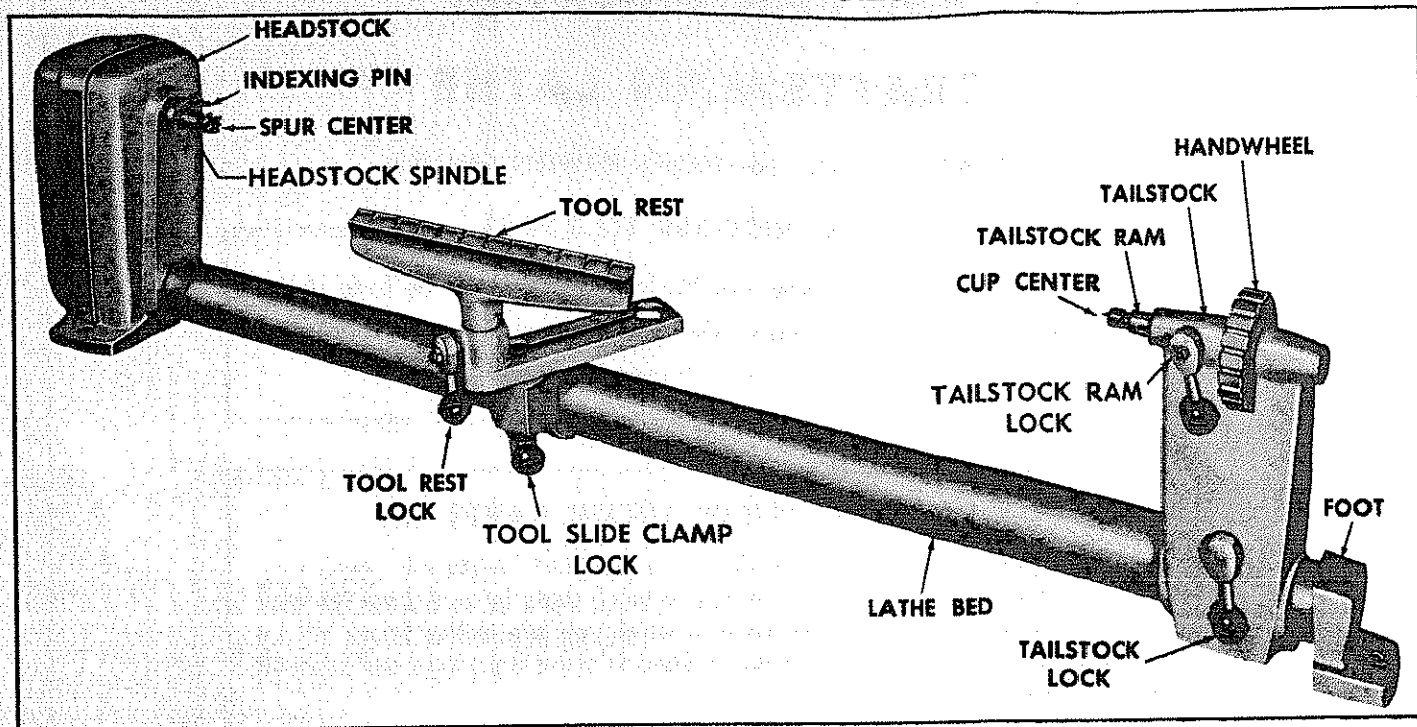

FIGURE 1

The styling of this new lathe will help modernize your workshop as well as give you an accurate and thoroughly engineered product. The mobile parts on the tubular bed can be positioned easily and locked positively for any stock up to 36 inches in length. The larger capacity allows face plate turning up to a foot in diameter.

ASSEMBLING:

This Lathe has been completely inspected and tested at the factory. Due to rough handling during shipment, the headstock has not been tightened to the column.

Before mounting the tool to a bench, align the tailstock and headstock in the following manner:

1. Place tool on bench top with the headstock extending over one edge to allow easy access to Socket Head Screw, No. 2.
2. Slide tailstock along column until the points of the two centers nearly meet and then lock tailstock to column.
3. Using one hand, rotate the tailstock and column until the two center points are exactly in line with one another.
4. Holding the tailstock in this position, securely tighten the Set Screw, No. 2, from the underside of the headstock.
5. If necessary, loosen screw, No. 34, only enough to reposition the foot, No. 33, so it rests flat on the bench top. Retighten securely after adjustment has been made.

Two hex wrenches have been placed in the instruction sheet envelope.

INSTALLATION:

Mount the lathe securely on work bench or table with screws or bolts. Three $\frac{3}{8}$ " diameter holes are provided for mounting, two are located in the base of the headstock and one is in the foot.

This lathe is so designed that the motor can be mounted on the bench to the rear of the headstock, or below on a bench shelf with the belt traveling through a hole cut in the bench. In either position, a hinged motor mount will make it easier to change the belt to different pulley steps for changing speeds. A standard $\frac{1}{2}$ " "V" belt is recommended. To install the belt, slip it through the opening in the headstock and onto the pulley.

LUBRICATION:

The precision ball bearings used in this lathe have been packed with grease at the factory. They should require no further lubrication for the life of the bearing. To maintain smooth efficient operations, a few drops of light oil should be applied occasionally to the tailstock screw and the tailstock ram. Wipe the tubular lathe bed occasionally with an oily rag to prevent rust and allow free movement of the tool rest clamp and tailstock.

SPEED AND ROTATION:

Check the direction of rotation when installing the motor. The spur center must turn counter clockwise when viewed from the tailstock end of the lathe.

Under normal conditions, best results will be obtained by using a 1/3 horsepower 1750 R.P.M. motor. For continuous heavy duty work, a 1/2 horsepower motor of the same speed is recommended. By using a four step motor pulley the same size as the spindle pulley, the following recommended speeds may be obtained.

Work Diameter	R.P.M. Roughing	R.P.M. Finishing
Up to 2"	2325	3450
2" to 3"	1325	2250
3" to 5"	825	1350
5" to 9"	825	875

The following table shows the diameter of the pulley step in which the belt should be placed in order to obtain the desired speed in Revolutions Per Minute.

R.P.M.	Lathe Pulley Step Dia.	Motor Pulley Step Dia.
3450	2"	4"
2250	2 3/8"	3 3/8"
1350	3 3/8"	2 5/8"
875	4"	2"

The four step motor pulley mentioned may be obtained from your Sears retail store or mail order house. Be sure to specify the shaft diameter of your motor when ordering this pulley.

CONTROLS: See Figure 1

TAILSTOCK LOCK:

Major adjustment of distance between centers may be made by loosening the tailstock lock allowing the operator to move the tailstock along the tubular bed to a desired position. The tailstock lock must be securely tightened before the work is under power.

HANDWHEEL:

Minor adjustments of distance between centers are made by turning the handwheel thus moving the cup center toward or away from the work piece as desired.

TAILSTOCK RAM LOCK:

As its name indicates, the ram lock holds the ram in a fixed position so that it will not move and loosen its grip on the work piece as a result of vibration. The tailstock ram must be locked securely in position during cutting operations on work between centers.

TOOL SLIDE LOCK CLAMP HANDLE:

Loosen the slide lock handle to change the angle of the tool rest holder or to change its position on the tubular bed. After the desired adjustment has been made re-tighten the handle.

TOOL REST LOCK:

Tool rest is fully adjustable for any turning operation. It is held securely by the tool rest lock.

INDEXING PIN:

The indexing pin is in line with a series of 36 equally spaced holes in the surface of the step pulley inside the headstock. This spring loaded pin, when

allowed to project through the casting and into a hole in the pulley, locks the entire turning assembly attached to the spindle.

Through the use of this pin, the spindle may be held stationary for various operations such as laying out patterns and centerlines on face plate work. The index pin provides a means of spacing the various cuts in fluting and reeding operations.

Do not use indexing pin for attaching or removal of face plates. A drilled hole in the headstock spindle collar is provided to remove face plates. An Allen wrench, large nail, or any similar item, approximately the same size as the hole, can be inserted and revolved until it bears against the indexing plunger. This will lock the spindle and allow the face plate to be unscrewed.

With the index pin engaged, the lathe may be used as a fixture for holding long twist or spiral work for the hand finishing operations. It is always a good policy to double check all control units before applying power with a job set up in the lathe. The operator should be sure that the tailstock and the tailstock ram are securely locked, that the tool rest and tool rest holder are held rigidly in position, that the belt is in the right pulley groove for the speed desired, and finally that the index pin is retracted and clear of the pulley.

The set screw, No. 30, in the tailstock should be checked occasionally to assure the proper pressure against the key and to keep tailstock at 90° to the tubular bed.

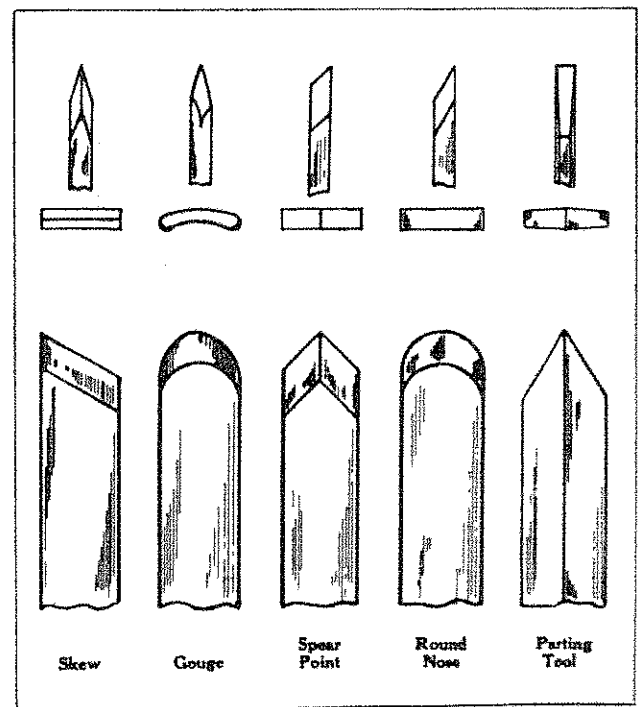

FIGURE 2

TURNING CHISELS:

The five basic types of turning chisels are shown in Figure 2. They are available in various sizes individually, or in matched sets.

The gouge chisel is used for the slower speed rough cutting operations as well as for finishing cuts on irregular shapes. The gouge should be used with the beveled edge down. The chisel should be rolled slightly in the direction in which it is advancing as shown in Figure 3.

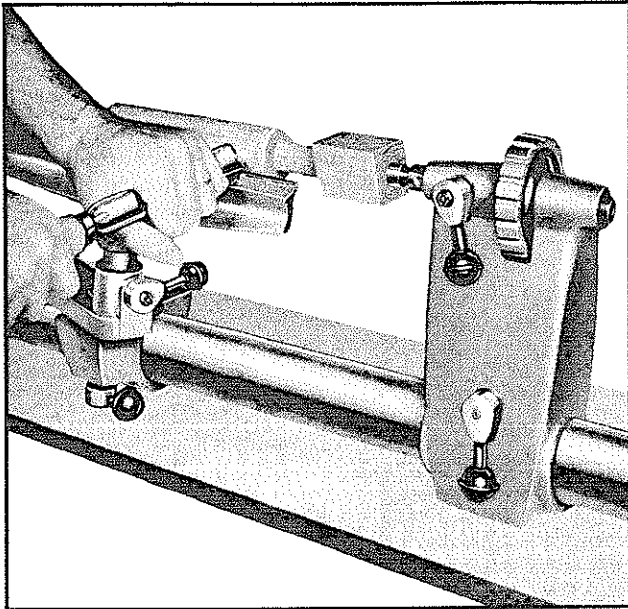

FIGURE 3

The skew chisel is used for finishing cuts on cylinder work with its edge at an angle to the axis of the work piece as shown in Figure 4. The skew is also often used to cut clearance behind a shoulder cut where cutting rather than scraping action is desired.

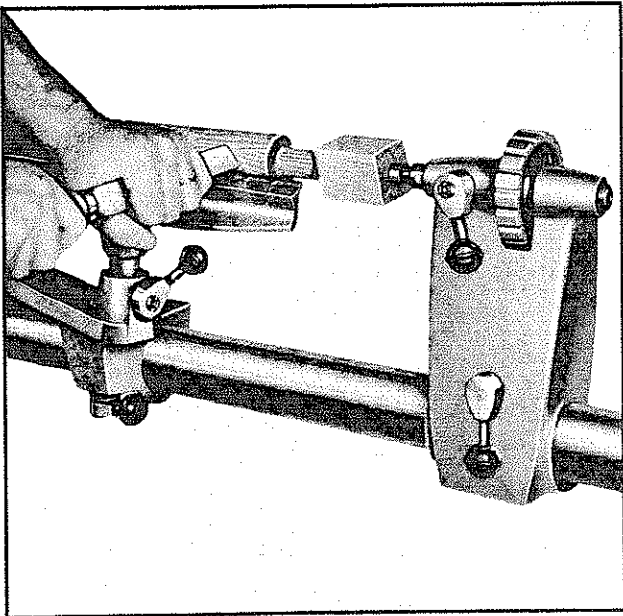

FIGURE 4

The spear point is used in a scraping manner by feeding the point directly into the work piece with the beveled side down.

The round nose chisel is recommended for cutting coves in face plate and cylindrical work. Like the spear point, the round nose chisel cuts in a scraping manner with the beveled side down.

The parting tool may be used for square cuts of many types: sizing cuts as shown in Figure 5, shoulder cuts, and perhaps most commonly for cutting off finished work as described later in this sheet. In addition to the above mentioned chisels, a regular square nose chisel is often found to be quite useful for certain wood turning operations.

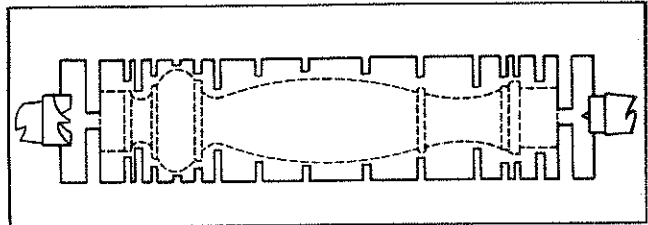

FIGURE 5

Best quality work is obtained only when a sharp edge is maintained on the cutting tools. When sharpening the chisels, grinding and honing should be done only on the bevels so as to preserve the original shape of the chisel. Skew chisels must be flat ground, not hollow ground.

OPERATION:

Pieces to be turned between centers such as table legs, lamp standards, etc. are usually turned from pieces of square cross section. The rough work piece should be cut at least $\frac{3}{4}$ inch longer than the finished piece to allow material for cut-off after turning is complete. To support the work properly between the centers, the ends must be cut square.

To locate the center on the ends of the work piece, draw diagonal lines from corner to corner on each end. Mark the center on each end with a punch or awl. In the case of hard wood it might be necessary to drill a small hole about $\frac{1}{8}$ inch deep at the center points and to make saw cuts $\frac{1}{8}$ inch deep along the diagonal lines on one end to allow proper seating of the spur center. In softer wood, the spur center as well as the cup center may be seated by tapping with a mallet. When the spur center has been set in the wood, mark a reference point on both the wood and the spur center so that the piece may be accurately recentered if removed from the lathe before completion.

Mount the work in the lathe between the two centers adding a small amount of lubricant to the cup center to minimize burning of the wood.

With the tailstock held firmly to the tubular bed, advance the tailstock ram until the work piece is held firmly. Retract the ram slightly until the piece turns freely between the centers. Lock the tailstock ram lock securely to maintain the position of the cup center.

ALWAYS TURN THE WORK PIECE BY HAND BEFORE APPLYING POWER.

The rough cut should be made with the gouge chisel. Remove the square edges with a series of short cuts, the first starting several inches from the cup center and working toward the tailstock, the second cut starting several inches from the first cut, etc. When a point several inches from the spur center is reached, turn the chisel and make the final cut in the direction of the headstock. Do not make long continuous cuts, and do not start a cut at the end of a work piece during roughing work with the gouge chisel. The shorter cuts starting in the body of the piece prevent splintering and tearing.

When the piece has been roughed out to within approximately $\frac{1}{8}$ inch of its finished diameter (check with calipers), stop the lathe, move the tool rest in to $\frac{1}{8}$ inch of the work piece, and set the belt into the proper pulley steps to provide the next highest speed as shown in speed table for finishing cuts.

At the beginning of the finishing cuts the ends of the piece may be accurately squared by using the parting tool or skew chisel as desired. The finishing cut may be made with the gouge or skew chisel depending on the shape of the finished piece. Straight surfaces are generally finished best with the skew chisel, while concave or convex surfaces work best with the gouge chisel. Best finishing results are obtained by making a fine cut in a shaving manner, feeding the chisel parallel to the axis of the work piece in a slow continuous movement, applying even pressure to the chisel throughout the cut.

When cutting special shapes, sizing cuts shown in Figure 5 may be made with the parting tool. These cuts can be made to within $\frac{1}{8}$ inch of the finished dimension. Diameters of these sizing cuts as well as any other cylinder work may be checked to the desired dimension by measuring with calipers as the cut is made.

Before sanding cylindrical work, feed the parting tool into the work at the points of cut-off until the diameter is reduced to about $\frac{1}{4}$ inch. Stop the lathe and remove the tool rest before sanding. Hold the sandpaper strips at each end and apply the paper lightly to the turning cylinder. **DO NOT WRAP THE PAPER AROUND THE WORK PIECE. THIS PRACTICE CAN RESULT IN SERIOUS INJURY.**

When the surface finishing operations (sanding—polishing, etc.) have been completed, the work piece may be cut-off either by feeding the parting tool through, or by stopping the lathe and cutting through with a saw.

TURNING FLAT WORK:

Surface turning on flat work such as ash trays and lamp bases, may be accomplished by attaching the work piece directly to a face plate with short screws, or by gluing the piece to a wood backing plate which has first been fastened to the faceplate and trued by turning. If the wood backing plate is used, glue a piece of paper between it and the work piece to facilitate separation after the turning is complete. Turn the

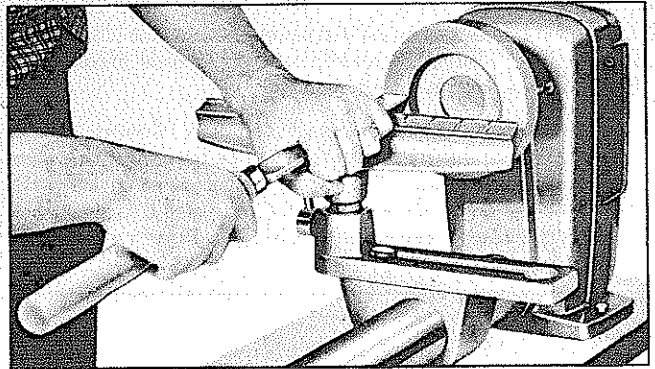

FIGURE 6

tool rest parallel to the face of the work piece as shown in Figure 6, and adjust the height so that the cut is taken at the centerline of the piece. Facing is generally accomplished with the chisel at right angles to the work piece taking somewhat of a scraping cut.

For face plate turning, the chisel should be placed so that the work turns down into it. In other words, cut to the left of center as shown in Fig. 6.

For further information or suggestions on the operation of the Lathe refer to the Wood Lathe manual which came with the tool.

SAFETY PRECAUTIONS:

Do not operate the lathe while wearing loose sleeves, dangling neckties, or any other type of loose clothing that might become entangled in the revolving work.

After setting the work up in the lathe, double check to be sure that it is mounted securely. Fast spinning pieces may cause serious damage if they break loose as a result of careless mounting. Always spin the work by hand before applying power.

Always use the tool rest when cutting with the chisels. Keep the tool rest close to the work, and keep the chisels sharp. Do not be afraid of high speeds on ordinary spindle work.

It is recommended that you install a motor switch at the left hand end of the lathe for quick power cut-off.

ACCESSORIES:

Face plates of various sizes, sanding discs, auxiliary centers, drill chucks, sanding drums, and jack shafts for greater speed range and variation may be purchased from your retail store or mail order house. A tool stand as shown below is also available.

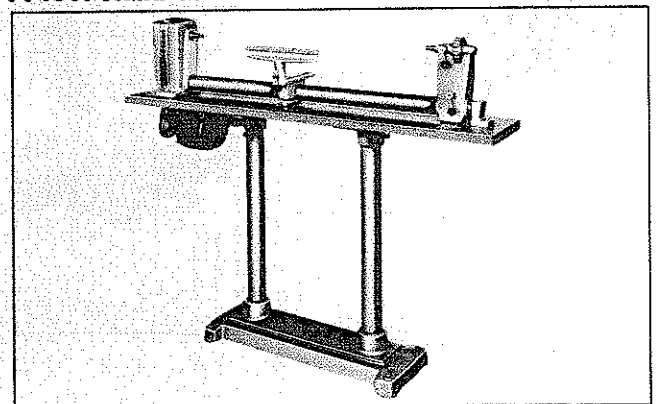

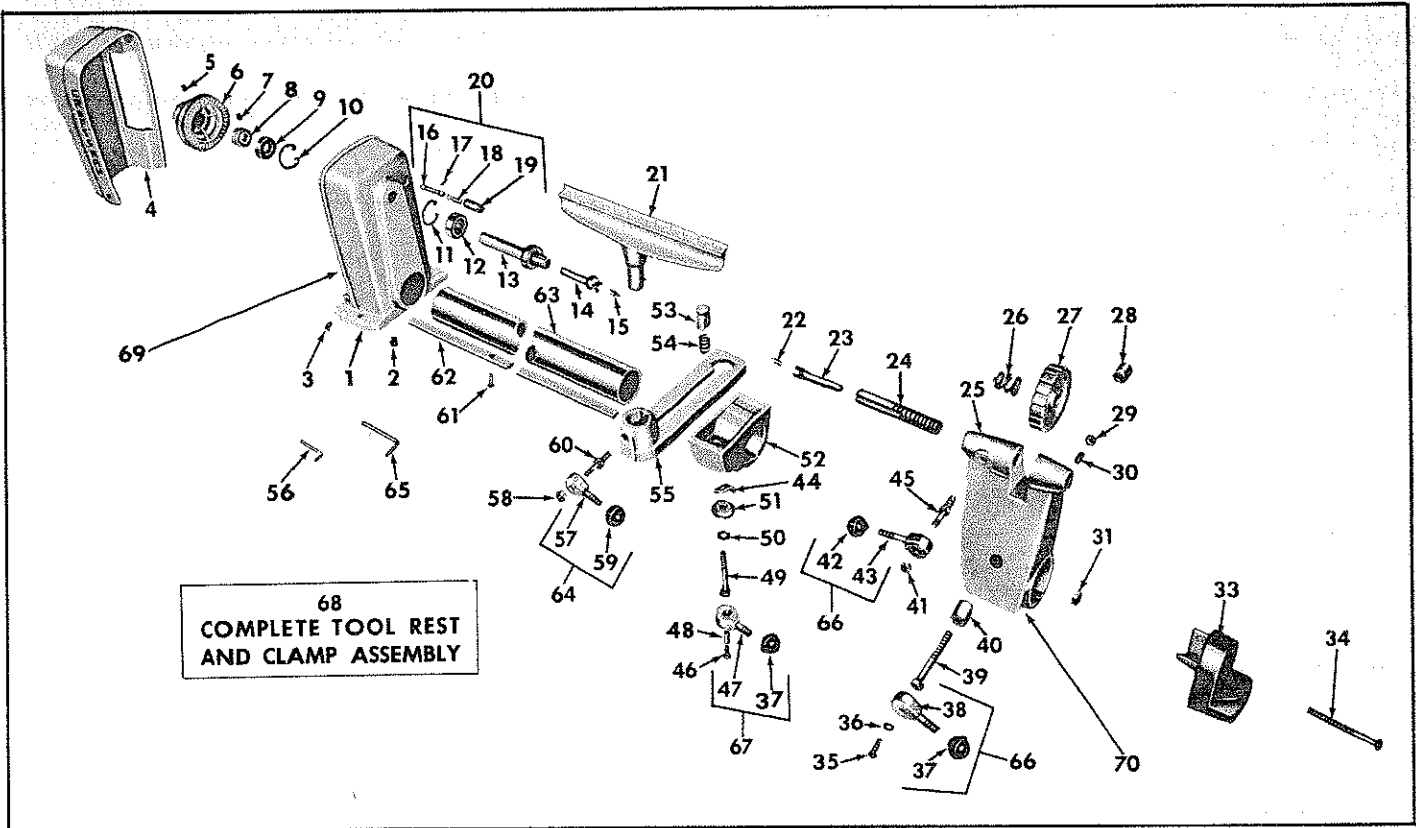

PARTS LIST

WHEN ORDERING REPAIR PARTS, ALWAYS GIVE THE FOLLOWING INFORMATION:

1. The PART NUMBER.
2. The PART NAME.
3. The MODEL NUMBER—103.23881
4. The Name of Item—LATHE.

Do not use Key Numbers when ordering Repair Parts, always use Part Numbers.

Key No.	Order By Part No.	Part Name	Key No.	Order By Part No.	Part Name
1	56211	Headstock	39	56624	Cap screw 5/16-18 x 3 hex. hd.
2	*X-3611	Set screw 3/8-16 x 1/2 soc. hd. cup point	40	56629	Barrel lock
3	*X-383	Machine screw 1/4-20 x 3/8 slot truss hd.	41	X-490	Hex locknut 1/4-20 N.F.
4	56713	Cover	42	38892	Knob
5	*X-179	Set screw 5/16-18 x 5/16 soc. hd. cup point	43	56210	Lock hub and stem assembly
6	56170	Pulley with set screws	44	38787	Shoe pad
7	*X-179	Set screw 5/16-18 x 5/16 soc. hd. cup point	45	56634	Stud-nut
8	56110	Collar with set screw	46	X-3902	Machine screw No. 10-24x1 hex washer head
9	18229	Ball bearing	47	56160	Support lock hub and stem assembly
10	38884	Retaining ring	48	56633	Spacer
11	38884	Retaining ring	49	56622	Cap screw 5/16-18 x 1 7/8 hex. hd.
12	18229	Ball bearing	50	*X-617	Plain washer 21/64 I.D. 9/16 O.D. x 18 ga.
13	56611	Spindle	51	38526	Shoe
14	56180	#1 Morse Taper Spur center with point (See below **)	52	38232	Support clamp
15	56619	Point	53	56632	Slide—threaded
16	56614	Plunger	54	56819	Spring
17	18994	Pin	55	56222	Tool rest holder
18	38896	Spring	56	X-1402	Allen wrench 3/16
19	56613	Plunger Housing	57	56210	Rest lock hub and stem assembly
20	56120	Plunger and housing assembly	58	X-490	Hex locknut 1/4-20 N.F.
21	56221	Tool rest	59	38892	Knob
22	56619	Point	60	56635	Stud-nut
23	56190	#1 Morse Taper Cup center with point (See below **)	61	38897	Riv nut—flat head
24	56625	Tailstock spindle	62	56616	Key
25	56212	Tailstock	63	56130	Tube key and pin assembly
26	56815	Spring	64	56104	Rest lock hub, stem and knob assembly
27	56217	Handwheel	65	*X-1403	Allen wrench 5/32
28	38631	Barrel lock	66	56102	Lock hub, stem and knob assembly
29	*X-430	Hex. nut 1/4-20 Am. std.	67	56103	Support lock hub, stem and knob assembly
30	56628	Set screw 1/4-20 x 1 1/4 slot. hd. full dog pt.	68	56005	Complete tool rest and clamp assembly consisting of 21, 22, 23, 24, 25, 26, 27, 28, 29, 30, 35, 36, 66, 39, 40, 41 and 45
31	*X-418	Square nut 5/16-18	69	56006	Headstock assembly complete consisting of Items No. 1, 2, 3, 4, 6, 8, 9, 10, 11, 12, 13, 14 and 20
33	56213	Rear foot	70	56004	Tailstock assembly complete consisting of Items No. 23, 24, 25, 26, 27, 28, 29, 30, 35, 36, 66, 39, 40, 41 and 45
34	X-572	Machine screw 5/16-18 x 1 3/4 slot. rd. hd.		56929	Instruction sheet and parts list
35	*X-344	Machine screw #8-32 x 1 phil. oval hd.			
36	X-2453	External tooth countersunk lock washer #8			
37	38892	Knob			
38	56150	Lock hub and stem assembly			

*Standard Hardware Items—May be Purchased Locally.

**Items are regular stock in Sears hardware departments and mail order houses. May also be ordered as repair parts by part number provided.

This sheet is intended for instruction and repair parts only and is not a packing slip. The parts shown and listed may include accessories not necessarily part of this tool.