

**OPERATING INSTRUCTIONS
AND PARTS LIST FOR**

**CRAFTSMAN
DRILL PRESS**

Model Number 103.23100

This is the model number of your Drill Press. It will be found on a plate located on the base near the column. Always mention this model number when communicating with us regarding your Drill Press or when ordering parts.

This list is valuable. It will assure your being able to obtain proper parts service. We suggest you keep it with other valuable papers.

SEARS, ROEBUCK and CO.

July, 1946

OPERATING INSTRUCTIONS AND PARTS LIST FOR CRAFTSMAN DRILL PRESS

MODEL NUMBER 103.23100

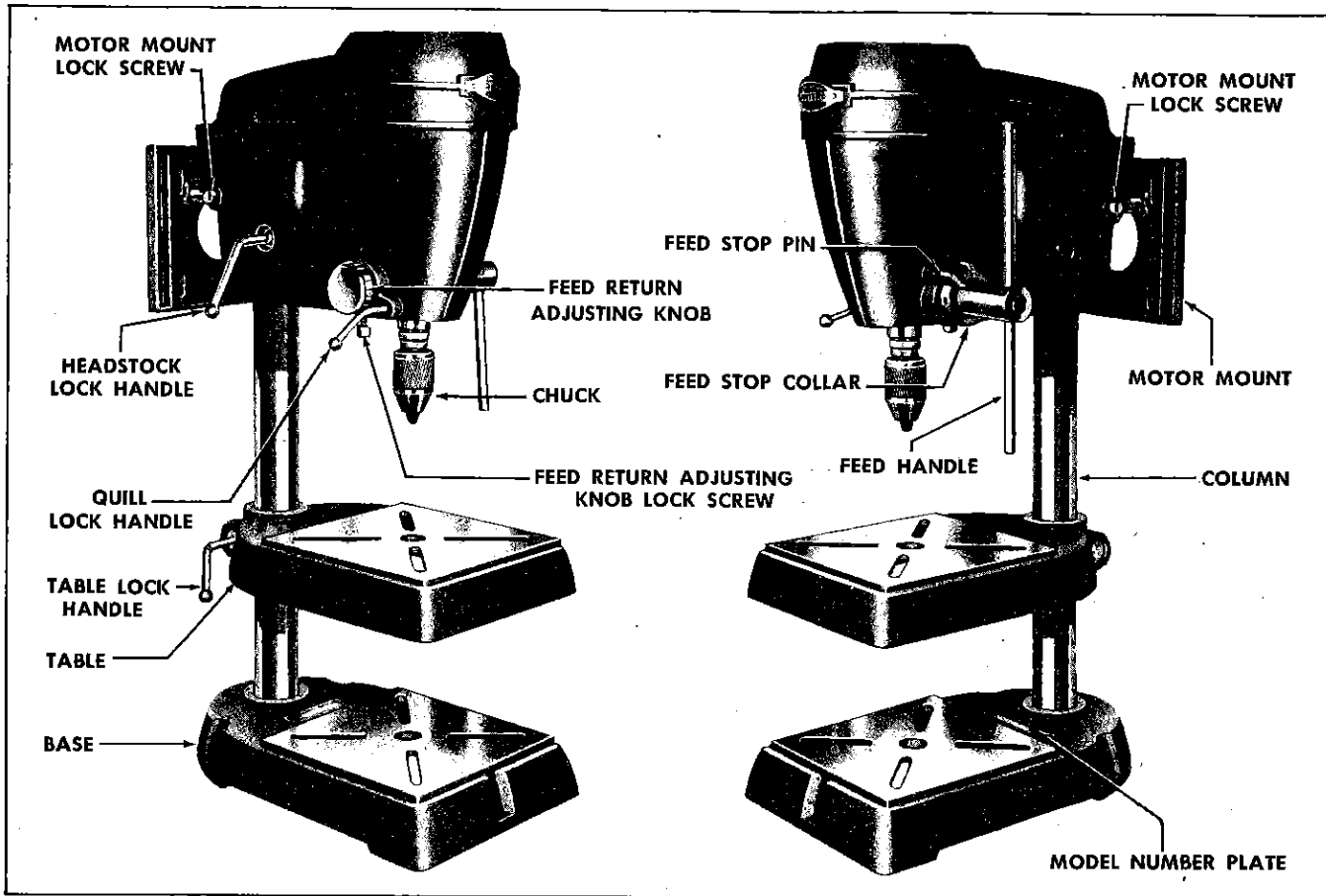

FIGURE 1

REASSEMBLING:

This drill press has been completely inspected and tested at the factory. To avoid loss of parts during shipment, the belt, the chuck, the motor pulley and its Allen wrench have been packed separately in an enclosed carton.

The chuck may be installed by turning it onto the threaded portion of the spindle.

INSTALLATION:

For proper operation, this drill press should be driven by a $\frac{1}{2}$ horsepower 1750 R.P.M. ball bearing motor. To install this motor back out the motor mount lock screws, Figure 1, until the motor mount may be removed. Fasten the motor to the mount with the bolts (X-322) provided, placing a washer (X-601) under each bolt head and each nut (X-417). Place the motor pulley on the shaft of the motor with the small step of the pulley toward the motor, and tighten the set screw securely with the Allen wrench provided. **The Direction of Rotation Must be Clockwise.** Replace the motor mount in its normal position as shown in Figure 1. For normal operation, the large step on the spindle pulley should be in line with the small step on the motor pulley. Place the belt around one of the steps on the spindle pulley and around the aligned step on the motor pulley. Tighten the belt by pulling the motor mount away from the

drill head. When the belt is tight, tighten the two motor mount lock screws securely.

The drill press should be bolted securely to a well constructed work stand or table before operating. Three $\frac{11}{32}$ inch holes are provided in the base for this purpose.

LUBRICATION:

An oil hole is provided in the outside surface of the casting directly over the pinion shaft 26623 through which oil may be applied to the pinion shaft. Another hole is provided in the top surface of the $2\frac{1}{2}$ inch diameter step of the spindle pulley through which oil when applied will reach all rotating parts requiring lubrication. An occasional application of oil to the splines at the top of the spindle will preserve the smooth feed action of your drill press. Care should be exercised so that oil does not get on the belt. A good quality light grade machine oil should be used for lubricating this drill press.

SPEED:

When the pulleys are in the same plane there are four speeds available. When a 1750 R.P.M. motor is used, the spindle will rotate at approximately 4000 R.P.M. when the largest step on the motor pulley and the smallest step on the spindle pulley are used. When using the next step down on each pulley, the resulting speed will be approximately 2275 R.P.M. A speed of approximately 1350 R.P.M. can be attained

by moving the belt to the third step from the top on each pulley. The lowest speed available, 750 R.P.M., can be obtained by placing the belt on the smallest step of the motor pulley and the largest step of the spindle pulley. Other speeds are attainable by changing the position of the motor pulley in relation to the spindle pulley so that further step combinations are created.

Due to variation in the bit pattern, the type, hardness, and grain of the material, and the depth and quality of the hole desired, it is impractical to attempt to establish a fixed table of drill feeds and speeds for boring in wood. It is best to follow this general rule: the larger the hole and the harder the material the slower the feed and speed. An approved method is to start any drilling operation with a moderate feed and speed, increasing either or both after noting the effect on the drill.

In wood drilling operations, drills up to $\frac{3}{4}$ inch in diameter may generally be run at 1800 to 3000 R.P.M. without burning while bits $\frac{3}{4}$ inch in diameter and over cannot generally be run over 2400 R.P.M. without burning. Multi-spur bits, expansive bits and hole saws should never be operated over 750 R.P.M. In general, if the drill smokes in the hole, reduce the feed and speed to prevent burning.

When drilling metal, if it is noted that the drill wears away at the extreme outer corners of the cutting edges, it is an indication of too much speed. Likewise if the drill chips on the cutting edge, it is an indication of too heavy a feed. Very small drills are generally designed for high speed and light feed and should be used accordingly for best results.

Always reduce the feed pressure when the drill is breaking through the surface of a work piece. This reduces the tendency of the drill to bite deeply at this point and thereby minimizes drill breakage.

CHUCK:

The chuck supplied with this drill press functions the same as chucks on regular hand drills. As it is threaded farther onto the spindle the jaws come closer together. This chuck will hold drills up to $\frac{1}{2}$ " shank diameter.

CONTROLS:

The chuck may be lowered approximately 3 inches by turning the pinion shaft counter clockwise. For this purpose, a feed lever or feed handle (Figure 1) is provided. The feed handle has an automatic spring loaded return action, and is designed to permit greater variety of feed pressures by incorporating an adjustable leverage feature. The feed handle is held in the pinion shaft 26623 by the thrust action of the spring 26813. Thus a leverage control is available so that the leverage may be increased to allow exertion of greater feed pressures without excessive hand pressure.

The feed stop collar (Figure 1) may be used when two or more holes must be drilled to the same depth, or where the depth of a blind hole must be set before drilling. The set screw X-173, when tight, locks the collar to the pinion 26623 at the desired setting.

The collar position may be determined for a particular setting by locking the drill at the desired depth setting by means of the quill lock handle. The collar may then be rotated counter clockwise on the pinion shaft until it hits the feed stop pin (Figure 1), at which point the collar should be locked securely by tightening the set screw X-173.

When performing operations such as shaping, fluting, and surface grinding, it is necessary that the

vertical position of the chuck remain fixed. For this purpose, the quill lock handle is provided. When tightened in a clockwise direction, this handle causes the quill 26120 to be held firmly in one position.

The table may be raised or lowered on the column to accommodate a thick work piece or a long drill by turning the table lock handle counter clockwise until the table moves freely. During this operation the table should be firmly supported to prevent its dropping quickly which might result in injury to the operator or breakage of parts.

The headstock lock handle functions in the same way as the table lock handle; however more care must be exercised when releasing the headstock lock handle due to the much greater weight of the parts supported.

ADJUSTMENTS:

For most satisfactory results, the Vee belt (X-1457) should be kept tight. Slippage of the belt under normal conditions is good indication that it should be tightened.

If the automatic feed return fails to bring the chuck back to the top of the stroke, or if the return action is sluggish, the tension may be increased as follows: lock the chuck at the top of its stroke by using the quill lock handle. Back out the feed return spring adjusting knob lock screw and turn the feed return spring adjusting knob counter clockwise several turns to build up spring tension. Tighten the lock screw to retain the tension. Loosen the quill lock and run the chuck down with the feed handle. If the tension is still not sufficient, it may be further increased by repeating the above adjustment.

If the headstock lock handle 26615 should strike the motor mount before locking, or if, in a locked position, it blocks accessibility to the motor mount lock screw, its position may be changed without disturbing its locking efficiency. The hex nut X-417 in the barrel lock 18121 may be removed and rotated after the handle has been disengaged from the nut threads. The rotation of the nut will allow the handle to lock in a new position, thus eliminating any interference.

TYPES OF BITS:

A variety of bits is available for use in your drill press. The solid center wood bit has a single flute turning around a solid center, but carries two spurs and two cutting edges.

The hollow spiral bit or ship auger is an excellent bit for drilling deep holes in wood. Its design permits very efficient removal of chips, necessary in deep hole drilling. The hollow spiral bit has but one cutting edge.

The fluted bit is an excellent all around wood boring tool. It has two flutes or twists, each terminating in a cutting edge and spur.

Perhaps the best bit for high quality machine drilling in wood is the spur machine bit in a twist drill pattern. It is a stiffer drill than any previously described, tracks nicely, and cuts an exceptionally smooth hole.

The twist drill while almost universally used for metal drilling with a 120° included angle between the cutting lips is readily adapted to wood drilling by grinding the angle to approximately 70° .

For larger holes, the multi-spur or rim type bit is often used. This type bit generally has a single cutting edge with several spurs arranged as saw teeth around the rim.

The expansive bit is a handy drilling tool for large holes due to the variety of hole sizes which may be drilled without having to stock separate drills of large diameters not often used.

When the expansive bit, as well as any of the previously described bits are used on the drill press, the screw point should be altered to a brad point by removing the threads with a file. This will not impair the efficiency of the bit and will prevent the coarse screw threads from engaging the wood and raising it from the table.

For use on the drill press the double lip style countersink is more desirable than the rosette type. The double lip style will make a cleaner cut and will tend to remain more clear of chips and gum under continuous operation.

While high speed steel drills generally give more satisfactory service for commercial operation because of higher speeds possible, and because they hold their edge longer, their greater cost often makes their use in the home shop unwarranted. Unless extensive metal drilling operations are planned, the less expensive carbon steel drills will give quite satisfactory results.

DRILL SHARPENING:

When grinding drills, in order to maintain the efficiency of the drill, extreme care should be exercised. The dead center or point of the drill must be maintained, that is, the cutting lips must be of equal length. Also their angle must be the same in relation to the axis of the drill, (approximately 60° each or 120° included angle between the cutting lips for metal, 35° each or 70° included for wood). The metal should be relieved gradually behind the cutting edge so that the included angle at the heel of the cutting lips will be approximately 12° on a side less than at the cutting edge itself.

OPERATION:

When the drill press is used for wood working it is advisable to fasten a smooth level auxiliary table of $\frac{3}{4}$ inch plywood to the metal table using countersunk flat head screws or bolts. This auxiliary table not only increases the working surface available, but provides a surface on which auxiliary fences, shaping guides, pivot pins and other similar units may easily be used. This auxiliary table also will minimize the danger of drilling through the work piece into the metal table.

If the drill is to pass completely through the work piece it is advisable to place a piece of scrap wood under the work piece at the point of breaking through to prevent splintering and mutilation of the lower surface as the bit breaks through. Another method of preserving the surface at drill break through is to reverse the wood and drill through from the opposite side as soon as the drill point emerges on the lower surface.

When boring to a definite depth in a blind hole the feed stop collar may be set to the desired depth limits by lowering the drill to a mark on the edge of the work piece corresponding to the hole depth

desired. When drilling to an approximate depth the graduated scale on the pinion shaft may be used.

A straight piece clamped to the table as a guide or fence has many uses, as in drilling several holes equidistant from a common edge or as a guide in grooving or fluting operations.

The work piece should be held securely on the table either by clamps or pins to prevent its turning with the drill. A drill vise is an inexpensive and very handy unit, designed to hold various odd shaped work pieces for drilling. Cylindrical work pieces such as dowels, or turned work pieces of various diameters present difficulties when an attempt is made to drill through or into their centers without an adequate stabilizing device. The drill vise or a V block should always be used for work of this type.

If the drill is long enough to go through the piece, but its penetration is limited by the travel or feed limit of the chuck, the piece may be set up on a block after the first cut of maximum feed depth has been made, thus allowing the drill to penetrate to its maximum length.

Holes through a piece, the thickness of which is greater than the drill length may often be completed by first establishing the location of the piece in relation to the drill center, then after drilling as far as possible from one side the piece may be reversed and the hole completed from the other side.

All metal work should be clamped securely to the work table before drilling is attempted. Should the drill lodge in a piece not clamped, it could easily tear the piece from the operator's grip resulting in injury to the operator as well as mutilation of the drill press and work piece. A punch mark on the metal surface at the center of the proposed hole will tend to keep the drill on center until the drill-spot is established.

Avoid set-ups which will allow the work to spring. This will help minimize drill breakage.

Lubricants should be used on all metals except cast iron which is drilled dry. For most metals, lard oil is a suitable lubricant, for the harder metals a solution of sal soda in water may be used.

This drill press is designed to give maximum protection from moving parts at all times. Since a guard on the chuck and drill would also hide the work, it must be impressed upon the operator that as with all rotating power tools, no loose clothing should be worn when working with the drill press.

The face should be kept away from the drill so that the hair does not become entangled with moving parts or that flying chips do not injure the operator.

Accessories are available with which further operations may be performed on your drill press such as dovetailing, shaping, routing, carving, sanding, spot finish or engine turn, cutting of plugs or dowels, fluting and reeding and buffing. An interesting booklet covering details on these various operations is available at your Sears' retail or mail order store.

HOW TO ORDER PARTS FOR MODEL NUMBER 103.23100 DRILL PRESS

All parts listed here must be ordered through a Sears retail or mail order store. Parts are shipped prepaid. When ordering repair parts, always give the following information:

1. The part number.
2. The part name and price.
3. The model number 103.23100 which will be found on a plate on the base near the column.

We suggest you write your order for repair parts like this sample.

Sears, Roebuck and Co.

Enclosed find my check for \$3.15 for which please send me the following parts for my drill press, Model Number 103.23100:

1 each No. 26611 Column \$3.00
1 each No. 26712 Column Plug15
\$3.15

Yours truly, John Martin,
Box 128, Richmond, Indiana

PARTS LIST

Part No.	NAME OF PART	Prepaid Selling Price (Each)	Part No.	NAME OF PART	Prepaid Selling Price (Each)
18019	Pulley (Spindle).....	\$ 1.80	26623	Pinion.....	\$2.75
18022	Pulley (Motor).....	1.70	26626	Feed Handle.....	.50
18109	1/2 Inch Drill Chuck (Tapped 1/4-20 Thread).....	1.75	26712	Column Plug.....	.15
18121	Headstock and Table Lock.....	.30	26713	Pointer.....	.15
18122	Headstock and Table Lock Sleeve.....	.30	26714	Steel Washer.....	.15
18124	Pin.....	.15	26716	Fibre Washer.....	.15
18217	Headstock Bushing.....	.40	26717	Steel Disc.....	.15
18221	Ball Bearing.....	.25	26718	Leather Disc.....	.15
18421	Washer.....	.15	26811	Snap Ring.....	.15
18511	Adj. Knob Lock Screw.....	.15	26812	Rubber Washer.....	.15
18614	Feed Return Adj. Knob.....	.65	26813	Feed Handle Thrust Spring.....	.15
18915	Feed Return Spring.....	.25	26814	Feed Handle Snap Ring.....	.15
26003	Head Frame Assy.....	16.00			
26120	Quill Assy.....	2.00		THE FOLLOWING PARTS ARE STANDARD AND MAY BE PURCHASED LOCALLY	
26130	Upper Spindle Collar & Set Screw.....	.30	X-160	Set Screw No. 6—32 x 1/4 Slotted Hd. Rd. Point.....	.10
26140	Feed Stop Collar & Set Screw.....	.50	X-171	Set Screw 1/4—20 x 3/8 Socket Hd. Cup Point.....	.10
26150	Motor Mount.....	2.50	X-172	Set Screw 1/4—20 x 5/16 Socket Hd. Cone Point.....	.10
26160	Lower Spindle Collar & Set Screw.....	.30	X-173	Set Screw 1/4—20 x 5/16 Socket Hd. Cup Point.....	.10
26211	Base.....	11.00	X-185	Set Screw 1/2—13 x 1-1/4 Square Hd. Cup Point.....	.10
26212	Lock Shoe.....	.25	X-205	Cap Screw 5/16—18 x 3/4 Hex Hd.....	.10
26213	Table.....	10.00	X-322	Mach. Bolt 5/16—18 x 2 Sq. Hd.....	.10
26611	Column.....	3.00	X-417	Hex Nut 5/16—18 Am. Std. Reg. Full.....	.10
26612	Table Lock Handle.....	.35	X-566	Mach. Screw No. 6—32 x 3/16 Round Hd.....	.10
26614	Pinion Retaining Screw.....	.15	X-601	Plain Washer 11/32.....	.10
26615	Headstock Lock Handle.....	.35	X-1405	Allen Wrench 1/8 Std.....	.15
26616	Quill Lock Handle.....	.20	X-1457	V-Belt 1/2 x 37 inch.....	1.25
26617	Splined Sleeve.....	2.00			
26618	Spindle.....	3.00			

This sheet is intended for instruction and repair parts only and is not a packing slip. The parts shown and listed may include accessories not necessarily part of this tool. All parts are shipped prepaid. All prices are subject to change without notice.

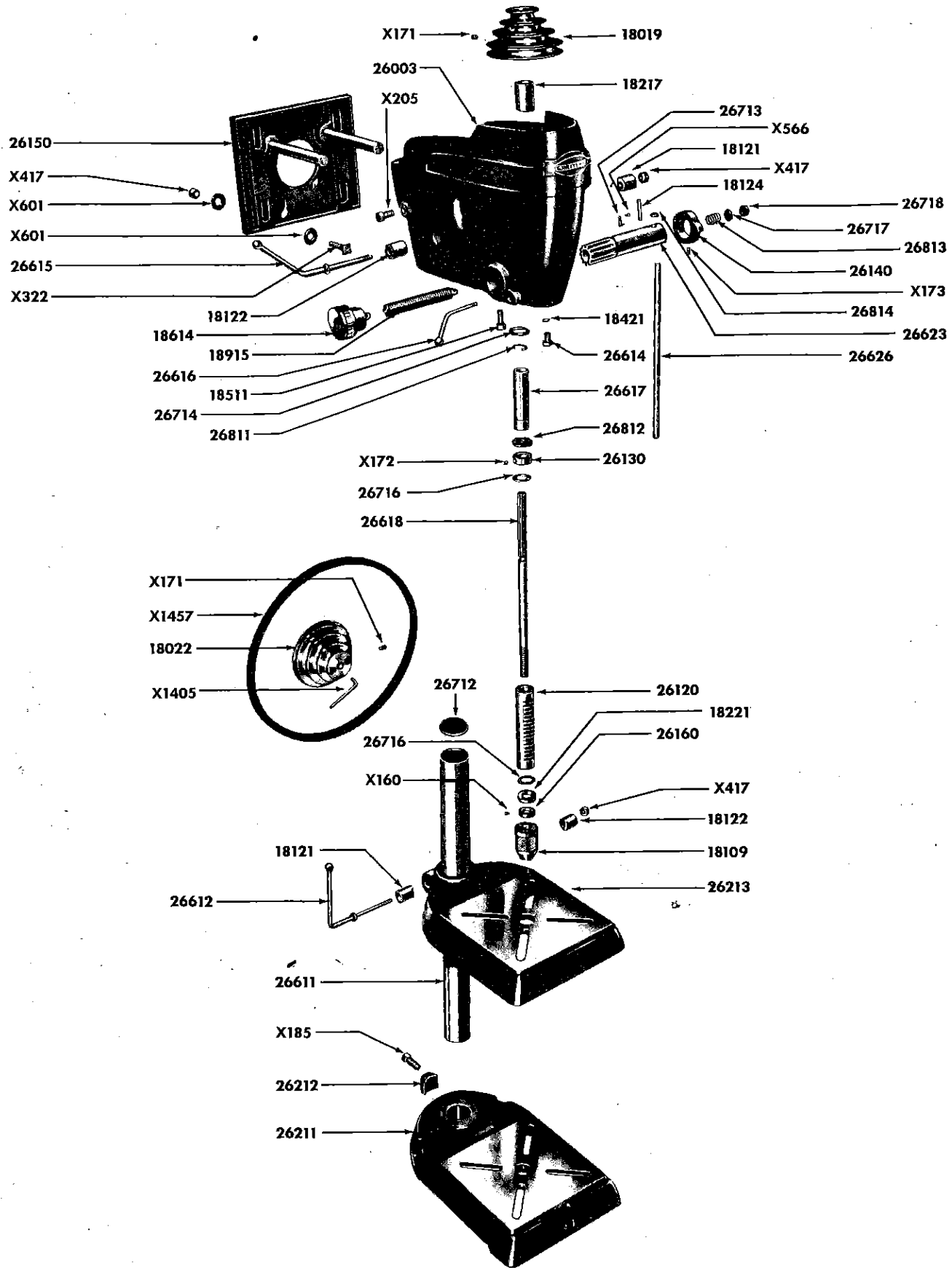

FIGURE 2