

SEARS

**owners
manual**

**MODEL NO.
149.236220**

SERIAL
OR CODE
NUMBER: _____

Model and code number may be
found on the side of the base.

You should record both model and
code number and retain in a safe
place for future use.

CAUTION:

**Read All Instructions
Carefully Before Start-
ing Assembly and Use.**

**Save This Manual For
Future Reference.**



SEARS / CRAFTSMAN®

**4 1/8-INCH
JOINTER — PLANER**

PROTECTIVE AND LUBRICATING OILS ARE
APPLIED TO THIS MACHINE DURING THE
MANUFACTURING PROCESS TO ASSURE
PROPER LUBRICATION. DURING INITIAL
OPERATION IT IS POSSIBLE THAT SOME
OF THESE OILS MAY BE OBSERVED COMING
FROM THE MACHINE. THIS IS NOT AN
INDICATION OF ANY KIND OF MALFUNCTION.

SEARS, ROEBUCK AND CO., Dept. 698/731A, Sears Tower, Chicago, IL 60684

WARRANTY ON CRAFTSMAN JOINTER — PLANER

purchase, this Craftsman Jointer — Planer fails due to a defect we will repair it, free of charge.

PLEASE CONTACT THE NEAREST SEARS STORE OR SERVICE CENTER

For legal rights and you may also have other rights which vary from state to state.

731A, Sears Tower, Chicago, IL 60684.

SAFETY RULES FOR POWER TOOLS



1. KNOW YOUR POWER TOOL

For your own safety, read the owner's manual carefully. Learn its application and limitations as well as the specific hazards peculiar to this tool.

2. GROUNDING INSTRUCTIONS

A. All grounded, cord-connected tools:

In the event of a malfunction or breakdown, grounding provides a path of least resistance for electric current to reduce the risk of electric shock. This tool is equipped with an electric cord having an equipment-grounding conductor and a grounding plug. The plug must be plugged into a matching outlet that is properly installed and grounded in accordance with all local codes and ordinances.

Do not modify the plug provided - if it will not fit the outlet, have the proper outlet installed by a qualified electrician.

Improper connection of the equipment-grounding conductor can result in a risk of electric shock. The conductor with insulation having an outer surface that is green with or without yellow stripes is the equipment-grounding conductor. If repair or replacement of the electric cord or plug is necessary, do not connect the equipment-grounding conductor to a live terminal.

Check with a qualified electrician or serviceman if the grounding instructions are not completely understood, or if in doubt as to whether the tool is properly grounded.

The use of any Extension Cord will cause some loss of power. To keep this to a minimum and to prevent overheating and motor burn-out, use the table below to determine the MINIMUM wire size (A.W.G.) Extension Cord.

Use only 3-wire extension cords that have 3-prong grounding plugs, and 3-pole receptacles that accept the tool's plug.

Extension Cord Length	Wire Size, A.W.G.
25-50 ft.	16
50-100 ft.	14
100-200 ft.	12

Extension Cords suitable for use with your Jointer-Planer are available at your nearest Sears Catalog Order or Retail Store.

Repair or replace damaged or worn cord immediately.

B. Grounded, cord-connected tools intended for use on a supply circuit having a nominal rating less than 150 volts:

This tool is intended for use on a circuit that has an outlet that looks like the one illustrated in Sketch A in Figure 1. The tool has a grounding plug that looks like the plug illustrated in Sketch A in Figure 1. A temporary adapter, which looks like the adapter illustrated in Sketches B and C, may be used to connect this plug to a 2-pole receptacle as shown in Sketch B if a properly grounded outlet is not available. The temporary adapter should be used only until a properly grounded outlet can be installed by a qualified electrician. The green-colored rigid ear, lug, etc. extending from the adapter must be connected to a permanent ground such as a properly grounded outlet box.

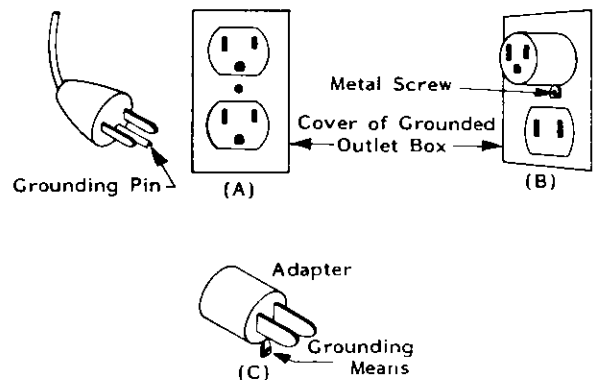

Figure 1 — Wiring Methods

3. KEEP GUARDS IN PLACE

in working order and in proper adjustment and alignment.

4. REMOVE ADJUSTING KEYS AND WRENCHES

Form habit of checking to see that keys and adjusting wrenches are removed from tool before turning on tool.

5. KEEP WORK AREA CLEAN

Cluttered areas and benches invite accidents.

6. **DON'T USE IN DANGEROUS ENVIRONMENT**
Don't use power tools in damp or wet locations, or expose them to rain. Keep work area well illuminated.
7. **KEEP CHILDREN AWAY**
All visitors should be kept a safe distance from work area.
8. **MAKE WORKSHOP KID PROOF**
with padlocks, master switches, or by removing starter keys.
9. **DON'T FORCE TOOL**
It will do the job better and be safer at the rate for which it was designed.
10. **USE RIGHT TOOL**
Don't force tool or attachment to do a job for which it was not designed.
11. **WEAR PROPER APPAREL**
No loose clothing, gloves, neckties, rings, bracelets, or jewelry to get caught in moving parts. Nonslip footwear is recommended. Wear protective hair covering to contain long hair.
12. **ALWAYS USE SAFETY GLASSES**
Also use face or dust mask if cutting operation is dusty. Everyday eyeglasses only have impact resistant lenses. They are NOT safety glasses.
13. **SECURE WORK**
Use clamps or a vise to hold work when practical. It's safer than using your hand and frees both hands to operate tool.
14. **DON'T OVERREACH**
Keep your proper footing and balance at all times.
15. **MAINTAIN TOOLS IN TOP CONDITION**
Keep tools sharp and clean for best and safest performance. Follow instructions for lubricating and changing accessories.
16. **DISCONNECT TOOLS FROM POWER SOURCE**
before servicing and when changing accessories such as blades, bits, cutters, or when mounting and re-mounting motor.
17. **AVOID ACCIDENTAL STARTING**
Make sure switch is in "OFF" position before plugging in cord.
18. **USE RECOMMENDED ACCESSORIES**
Consult the owner's manual for recommended accessories. Use of improper accessories may be hazardous.
19. **NEVER STAND ON TOOL**
Serious injury could occur if the tool is tipped or if the cutting tool is unintentionally contacted.
20. **CHECK DAMAGED PARTS**
Before further use of the tool, a guard or other part that is damaged should be carefully checked to ensure that it will operate properly and perform its intended function - check for alignment of moving parts, binding of moving parts, breakage of parts, mounting, and any other conditions that may affect its operation. A guard or other part that is damaged should be properly repaired or replaced.
21. **DIRECTION OF FEED**
Feed work into a blade or cutter against the direction of rotation of the blade or cutter only.
22. **NEVER LEAVE TOOL RUNNING UNATTENDED. TURN POWER OFF.** Don't leave tool until it comes to a complete stop.



The operation of any power tool can result in foreign objects being thrown into the eyes, which can result in severe eye damage. Always wear safety goggles complying with ANSI Z87.1 (shown on Package) before commencing power tool operation. Safety Goggles are available at Sears retail or catalog stores.

TABLE OF CONTENTS

GENERAL SAFETY RULES FOR POWER TOOLS	2-3
UNPACKING AND CHECKING CONTENTS	4
SAFETY RULES FOR JOINTER-PLANER.....	5
ASSEMBLY	5-8
Depth of Cut Hand Knob	5
Chip Deflector.....	5
Checking Cutter Blades	6
Fence.....	6-7
Fence Extension.....	7
INSTALLING THE JOINTER-PLANER	8
CONTROLS AND ADJUSTMENTS	8-10
Depth of Cut Hand Knob	8-9
Fence Adjustment	9
Cutter Guard	9
ON/OFF Switch.....	9
BASIC JOINTER-PLANER OPERATION	10-12
Feeding the Workpiece	10
Using Holddown/Push Blocks	11
Beveling, Chamfering.....	11, 12
Using a Wet/Dry Vac	12
MAINTENANCE	12, 13
Timing Belt Replacement	12
Cutter Guard Return Spring	12
Blade Replacement and Adjustment	13
General Maintenance	13
REPAIR PARTS.....	14, 15
TROUBLE SHOOTING.....	16
How to Order Replacement Parts	16

UNPACKING AND CHECKING CONTENTS

Model 149.236220 Jointer-Planer is shipped complete in one carton.

Separate all parts from packing materials and check each one with the illustration and the list of loose parts to make certain all items are accounted for, before discarding any packing material.

If any parts are missing, do not attempt to assemble the jointer-planer, plug in the power cord or turn the switch on until the missing parts are obtained and are installed correctly.

Wipe all parts thoroughly with a clean, dry cloth.

Apply a coat of automobile wax to the tables.

WARNING: FOR YOUR OWN SAFETY, NEVER CONNECT TO POWER SOURCE UNTIL ALL ASSEMBLY STEPS ARE COMPLETE, AND YOU HAVE READ AND UNDERSTAND THE SAFETY AND OPERATIONAL INSTRUCTIONS.

BOLT FINDER

Use to identify fastener size. Hold head of screw against folded edge. Inside diameter of sized circle is for nut, outside diameter is for screw.

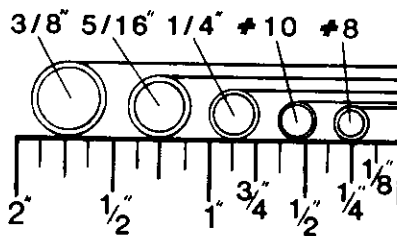

FOLD ALONG DOTTED LINE TO USE BOLT FINDER.

TABLE OF LOOSE PARTS

ITEM NO.	DESCRIPTION	QTY.
A	Jointer-Planer	1
B	Fence	1
C	Fence Bracket	2
D	Fence Segment	2
E	Tilt Indicator	2
F	Chip Deflector	1
G	Table Height Knob	1
*H	3/8" Lockwasher	1
*J	1/4"-20 x 3/4" Hex Cap Screw	4
*K	1/4 Split Lockwasher	4
*L	1/4 Flat Washer	4
M	Fence Lock Knobs	2
*N	9/32" ID x 17/32" OD x 1/8" Thick Washer	2
*O	#10-24 x 3/8 Machine Screw	2
*P	#10 Flat Washer	2
*Q	#8-32 x 1/2" Flat Head Machine Screw	6
*R	#8-32 Hex Nut	6
*S	#8 Flat Washer	6
T	Push Block	2
U	2-1/2" to 1-1/4" Vac. Hose Adapter	1
V	5/32" Hex Key (Allen Wrench)	1
W	Owner's Manual	1

* Supplied in loose parts bag

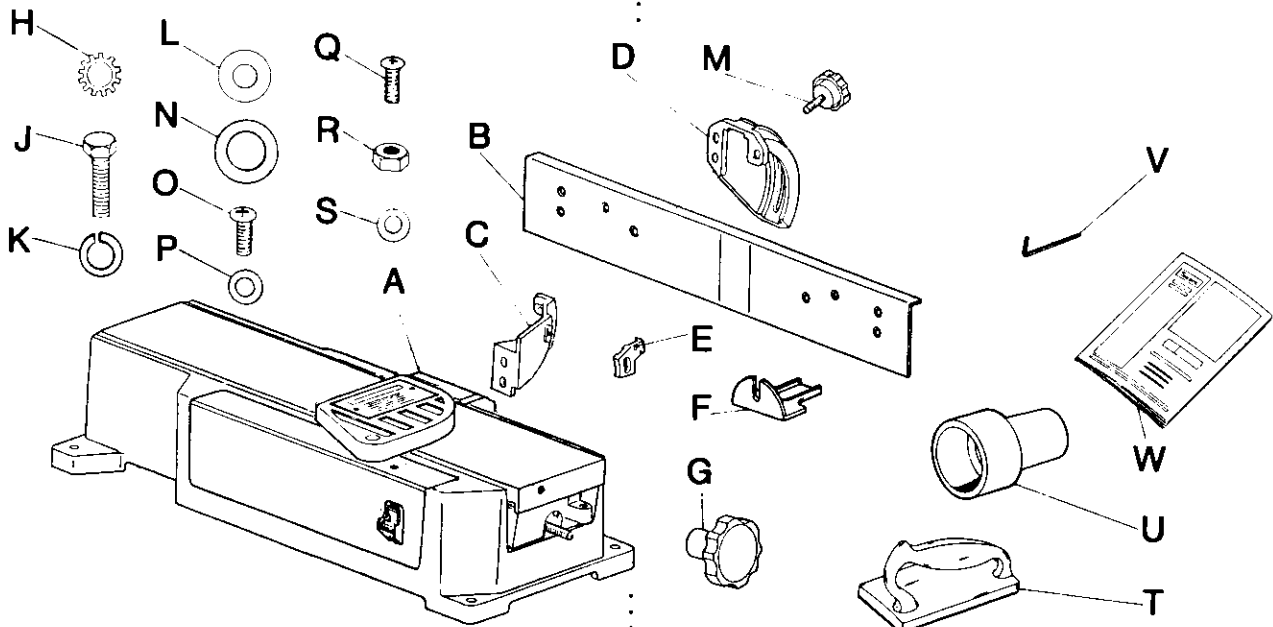

TOOLS REQUIRED

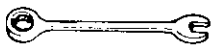

14mm or 9/16" Wrench
10mm Wrench
8mm or 5/16" Wrench

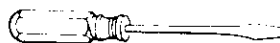

Medium Slotted Screwdriver
#2 Phillips Screwdriver

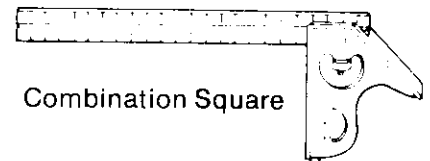

Combination Square

! SAFETY RULES FOR JOINTER—PLANER !

Safety is a combination of operator common sense and alertness at all times when the Jointer—Planer is being used. Study these rules and general safety rules before operating and retain them for future use.

1. WEAR EYE PROTECTION.
2. NEVER MAKE JOINTING OR PLANING CUT DEEPER THAN 1/8 INCH — PER PASS.
3. FEED WORKPIECE AGAINST ROTATION OF CUTTER.
4. KEEP FINGERS AWAY FROM REVOLVING CUTTER — use fixtures when necessary.
5. NEVER PERFORM JOINTING OR PLANING OPERATION WITH CUTTER HEAD GUARD REMOVED.
6. NEVER FORCE CUTTING ACTION. Stalling or partial stalling of motor can cause major damage. Allow motor to reach full speed before cutting.
7. NEVER - Attempt to perform an abnormal or little used operation without study and the use of adequate hold down /push blocks, jigs, fixtures, stops, etc.
8. NEVER - Attempt to cut small pieces.
9. ALWAYS - Use hold down/push blocks for jointing material narrower than 3 inches, or planing material thinner than 3 inches.
10. ALWAYS - Keep cutter sharp.
11. NEVER - Use in an explosive atmosphere. Normal sparking of motor may ignite fumes.
12. OUTDOOR EXTENSION CORD USE - When tool is used outdoors, use only extension cords suitable for use outdoors. Outdoor approved cords are marked with the suffix W-A, for example - SJTW-A or SJOW-A.
13. ALWAYS use identical replacement parts when servicing.
14. This tool is intended for RESIDENTIAL USE ONLY.

WARNING: DO NOT ALLOW FAMILIARITY (GAINED FROM FREQUENT USE OF YOUR JOINTER—PLANER) TO BECOME COMMONPLACE. ALWAYS REMEMBER THAT A CARELESS FRACTION OF A SECOND IS SUFFICIENT TO INFLICT SEVERE INJURY.



WARNING: DO NOT AT ANY TIME LET BRAKE FLUIDS, GASOLINE, PENETRATING OILS, ETC. COME IN CONTACT WITH PLASTIC PARTS. THEY CONTAIN CHEMICALS THAT CAN DAMAGE AND/OR DESTROY PLASTICS.

ASSEMBLY

DEPTH OF CUT HAND KNOB

1. Find one 3/8 lockwasher and the depth of cut hand knob from the parts bag.
2. Turn the nut on the height adjustment screw until five full threads extend beyond the nut.
3. Place lockwasher on height adjustment screw and thread hand knob onto screw.
4. Back nut up against hub of hand knob. Tighten with 14mm or 9/16 wrench while holding hand knob.

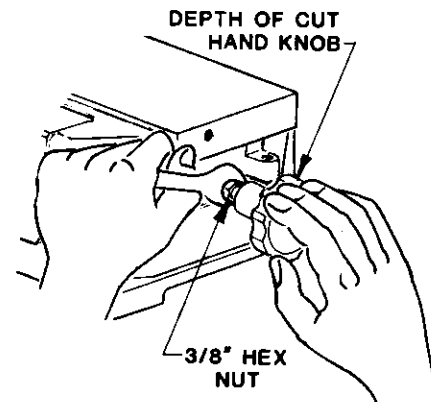

CHIP DEFLECTOR

1. Loosen the screw in the center of vacuum port of chip discharge.
2. Install slot of chip deflector between the chip discharge and the flat washer and retighten.



CAUTION: THE CHIP DEFLECTOR MUST BE IN PLACE FOR SAFE OPERATION. FAILURE TO INSTALL THE CHIP DEFLECTOR MAY RESULT IN PERSONAL INJURY.

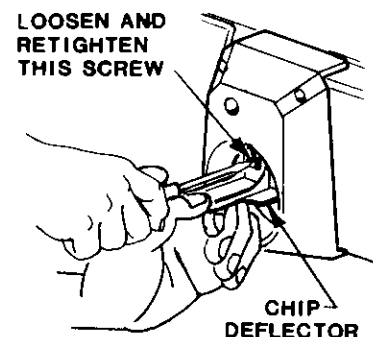

CHECKING CUTTER BLADES



CAUTION: MAKE SURE THE SWITCH IS IN THE OFF POSITION AND CORD IS UNPLUGGED BEFORE PROCEEDING WITH CHECKING CUTTER BLADES.

The blades in your Jointer-Planer have been adjusted at the factory to assure proper operation. Shipping and handling, however, may cause misalignment. For accurate cutting, the blades must be .003-in. higher than the outfeed table (thickness of a piece of paper) when positioned at the highest point.

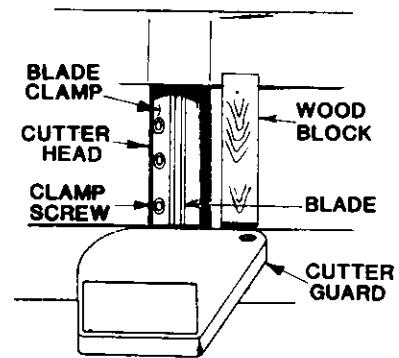

1. Block the cutter guard open with a scrap piece of wood about 4-1/2" long between the fence and cutter guard.

2. Locate the slot in the cutter head shaft through the small hole in the backside of the machine directly above the vacuum port. Rotate the cutter head with a screwdriver until one of the blades is at its highest position.
3. Place a straight edge over the outfeed table and the blade. The straight edge must touch evenly on the outfeed table at both ends of the blade. Rotate the cutterhead slowly, and making sure the blade lightly touches the straight edge. If the straight edge rises or blades do not touch, follow the "RE-PLACING CUTTER BLADES" procedure in the "MAINTENANCE" section.

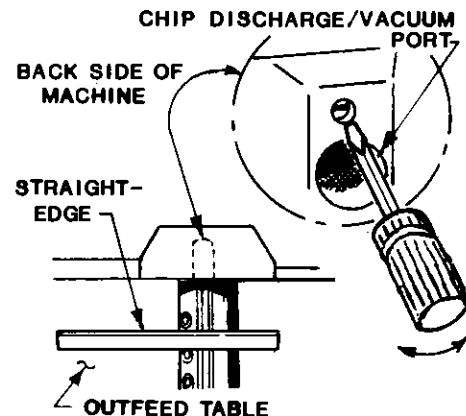

FENCE

1. From among the loose parts find the following:

- (1) Fence
- (2) Fence Brackets
- (2) Fence Segments
- (2) Tilt Indicators
- (2) Lock Knobs
- (4) 1/4-20 x 3/4" Hex Cap Screws
- (4) 1/4 Lock Washers
- (4) 9/32 ID x 9/16 OD x 1/16 Thick Washers
- (2) 9/32 ID x 17/32 OD x 1/8 Thick Washers
- (6) #8-32 x 1/2 Flat Head Machine Screws
- (6) #8 Flat Washers
- (6) #8-32 Hex Nuts
- (2) #10-24 x 3/8 Pan Head Machine Screws
- (2) #10 Flat Washers

1. Attach fence brackets to base using 1/4-20 x 3/4 hex cap screws, 9/32 ID x 1/16 thick washers and 1/4 lock washers, snug but do not tighten.
2. Attach fence segments to fence with #8-32 flat head screws, #8 flat washers and #8-32 hex nuts.
3. Place assembled fence on machine with fence brackets inside the fence segments.
4. Position lock knobs with 9/32 ID x 17/32 OD x 1/8 thick washers thru slots in fence segments and thread into fence brackets.

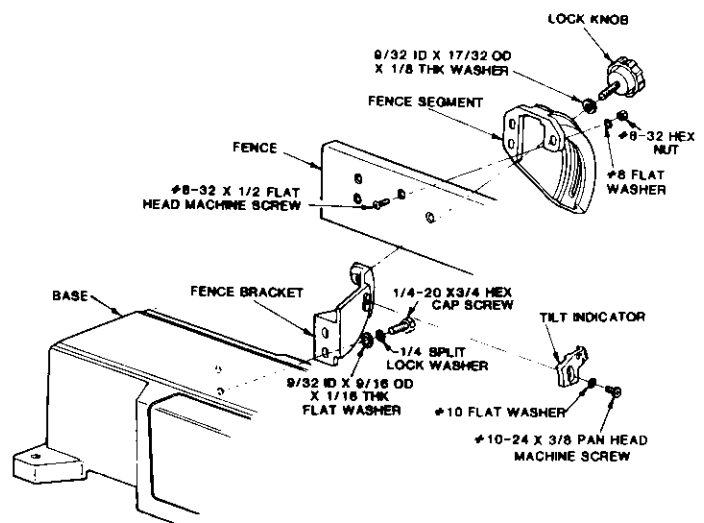

5. Place square against face of fence and table surface. Bring fence square to table and tighten lock knobs.

6. THERE MUST BE 1/32" TO 1/16" gap between the lower edge of the fence and jointer tables (with table set for 0" cut). To adjust, move fence assembly by loosening the 1/4-20 x 3/4 hex cap screws attaching the fence brackets to the base. Retighten hex cap screws after adjustment has been made.

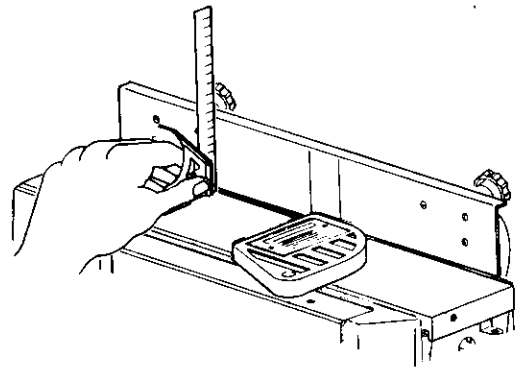

7. Recheck squareness of fence.

8. Install tilt indicators with #10-24 x 3/8 pan head machine screw and #10 flat washers. Set 0° of indicators to 0° of segments, and tighten the screw.

9. The fence should now be adjusted and will accurately measure angles to 45° inboard and 45° outboard (see adjustments section).

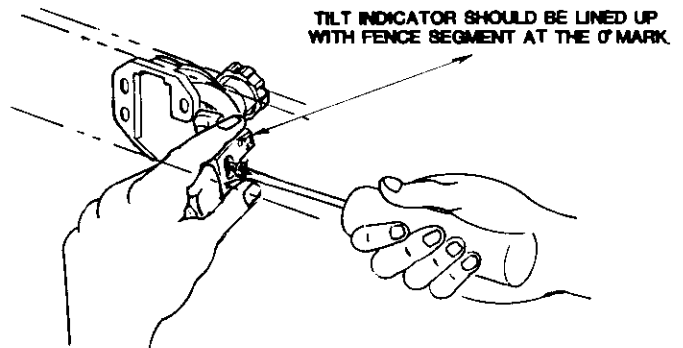

FENCE EXTENSION

To aid in edge jointing of workpieces 4" and wider, you may extend the fence height. The extension can be constructed of 1" (3/4" thick) stock pine or hardwood.

Use #8 flat head wood screws of sufficient length to securely attach the extension to the fence. Make sure that the head of the screws are below the surface of the fence so as not to interfere with the workpiece.

For extra stability, additional countersunk holes may be drilled in the fence for flat head screws.

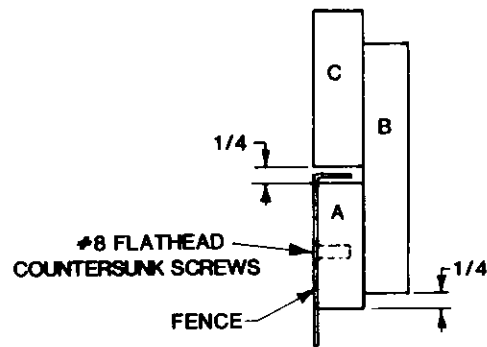

A = 11/16" Thick x 2" Wide x 10" Long
The 11/16" thickness can be obtained by planing the board on the jointer-planer.

B = 1/2" to 3/4" Thick x 3-1/2" Wide x 10" Long
This piece may also be made out of plywood.

C = 3/4" Thick x 2-1/2" Wide x 19-1/2" Long
The 2-1/2" width may be increased if desired.

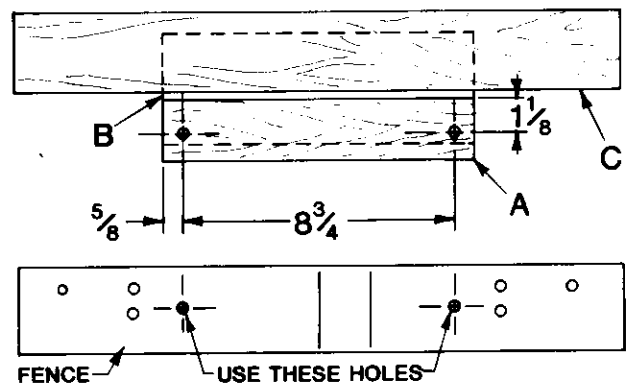

INSTALLING THE JOINTER—PLANER

If the Jointer-Planer is to be used in a permanent location, it should be fastened securely to a firm supporting surface such as a workbench. Holes should be drilled through supporting surface of the workbench as illustrated. Each foot of the Jointer-Planer should be bolted securely using 5/16" diameter machine bolts, 5/16" hex nuts, and lock washers. Bolts should be of sufficient length to accommodate foot of Jointer-Planer, washer, hex nuts, and thickness of supporting surface. Tighten all four bolts securely. If the Jointer-Planer is to be used in a portable application, it is recommended that it be fastened to a mounting board. The board should be of sufficient size to avoid tipping of Jointer-Planer while in use. Any good grade of plywood or chip-board with a 3/4" minimum thickness is recommended. Mount Jointer-Planer to board using hole pattern as shown. Clamp board securely to workbench or supporting surface.

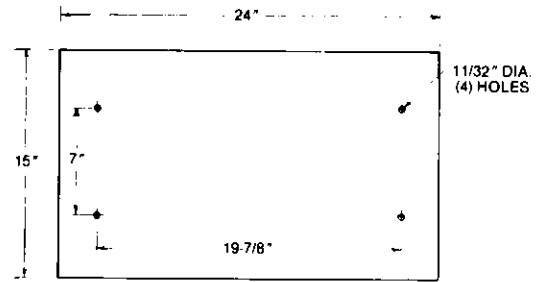

Supporting surface where Jointer-Planer is mounted should be examined carefully after mounting to insure that no movement during use can result. If any "tipping" or "walking" is noted, secure workbench or supporting surface before operating.

CONTROLS AND ADJUSTMENTS

CAUTION: MAKE SURE THE SWITCH IS OFF AND THE CORD IS UNPLUGGED BEFORE PERFORMING ANY CHECKS OR ADJUSTMENTS.

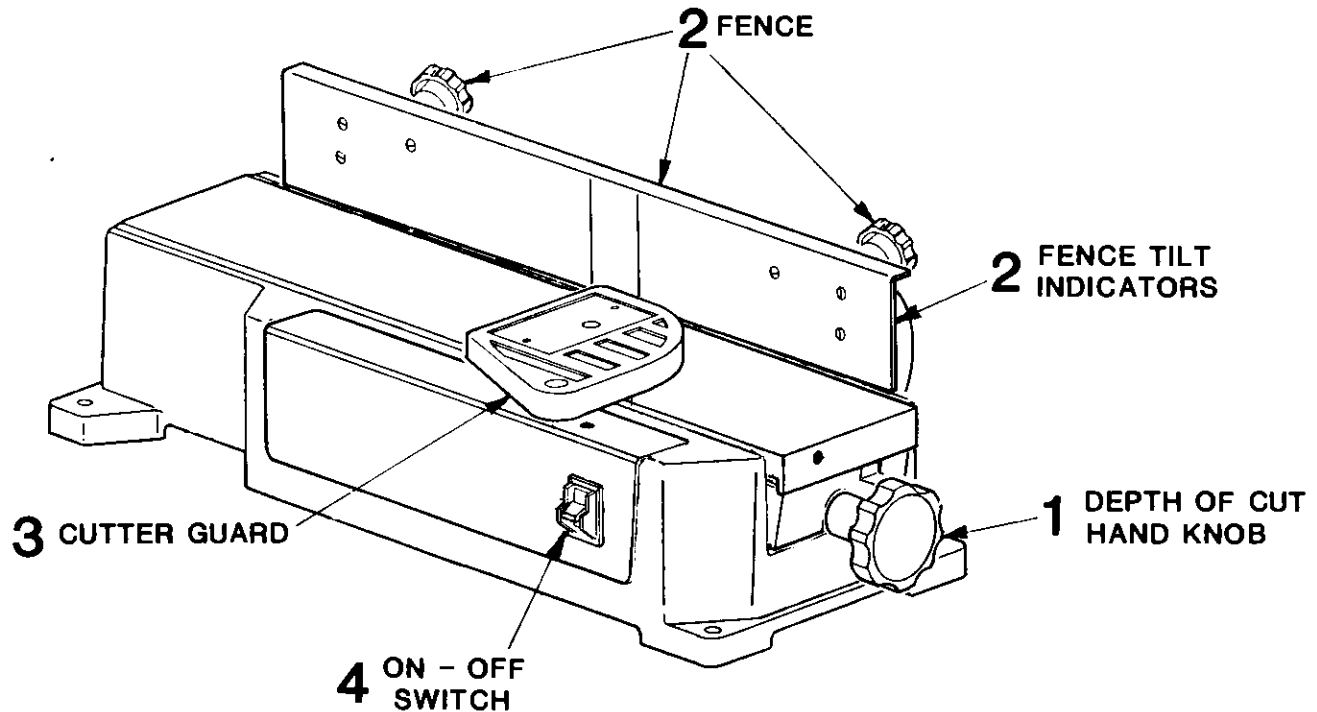

1. DEPTH OF CUT HAND KNOB

Turning the hand knob clockwise raises the infeed table and decreases the depth of cut. Turning it counter-clockwise lowers the infeed table and increases the depth of cut to the maximum 1/8" depth per pass.

NOTE: When the table is lowered for the maximum 1/8" depth cut, the hand knob will be relieved of tension and will be loose. If this is disturbing, simply turn the hand knob clockwise until it is again under tension. Turn the knob no more than 1/2 turn after it is again under tension. This will not change the depth of cut setting unless 1/2 turn is exceeded.

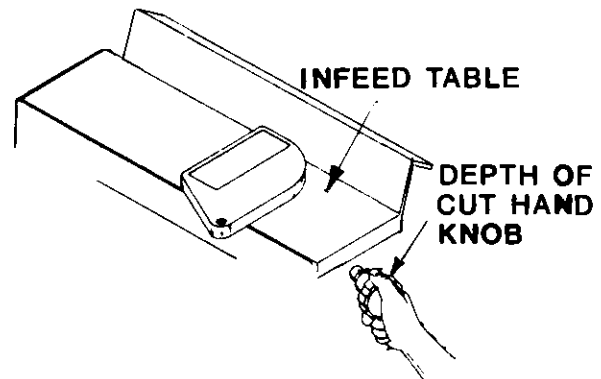

TO CHECK DEPTH OF CUT

- Place a straight edge on the outfeed table extending over the infeed table.
- Measure from the surface of the infeed table to the bottom of the straight edge. This will be the depth of cut.

NOTE: This Jointer-Planer will make a maximum 1/8" deep cut. To reduce the DANGER of kickback and possible injury, the depth of cut should not exceed 1/16" when cutting wood wider than 1-1/2".



CAUTION: MAKE SURE THE SWITCH IS OFF AND THE CORD IS UNPLUGGED BEFORE PERFORMING THIS CHECK.

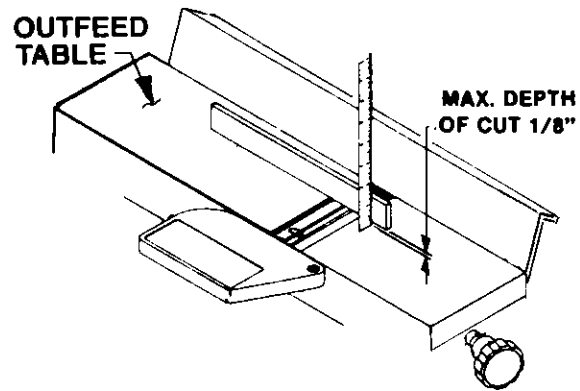

2. FENCE ADJUSTMENT

The fence can be adjusted to cut various angles from 0° to 45°. The fence can be tilted inboard (toward the cutter head) to maintain greater stability of a narrow workpiece or 45° outboard (away from cutter head) for larger angle cutting operations.

TO ADJUST: Loosen fence lock knobs and move the fence to desired position. The angle setting is marked on both fence segment pieces. Set the (0°) arrow of the clear plastic tilt indicator on the segment marks for 5° increments. For 1° increments, set the fence segment mark between the 0° to 5° marks on the tilt indicators. For outboard tilt, *add* the reading on the tilt indicator to the reading on the segment. For inboard tilt, *subtract* the tilt indicator reading from the reading on the segment. Tighten the lock knobs to maintain the desired setting.

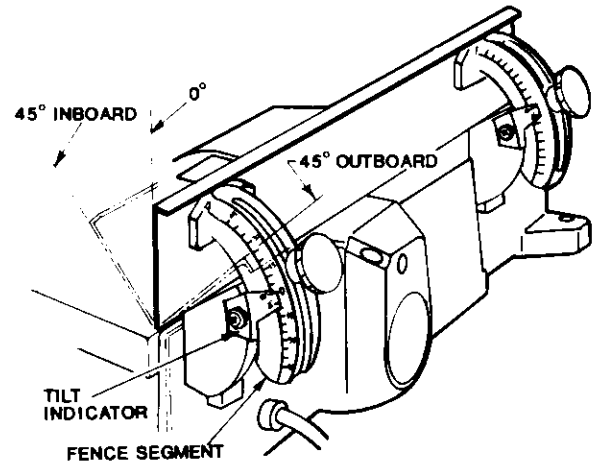

3. CUTTER GUARD

The cutter guard provides protection over the cutter head. It must always be in place and functioning properly.

Check the guard to make sure it is functioning properly.

- Pass a 1/4" thick piece of wood over the cutter head between the guard and fence. The guard must return automatically.

- Open the cutter guard all the way until it stops and release it several times. It should always return to its original position.



CAUTION: IF THE CUTTER GUARD FAILS TO OPERATE PROPERLY, THE CUTTER GUARD RETURN SPRING WILL NEED REPLACING. CONTACT YOUR NEAREST SEARS STORE OR SERVICE CENTER FOR REPLACEMENT SPRING AND INSTRUCTIONS BEFORE USING THE JOINTER-PLANER.

4. ON-OFF SWITCH

The operating positions of the "On-Off" switch are located on the front of your Jointer-Planer. Push the switch up to turn your Jointer-Planer "on" and down to turn your Jointer-Planer "off". The switch has a switch key which, when removed, allows the switch to be locked in the "off" position. To activate the locking feature push switch to "off" position and pull switch key.



WARNING: BE SURE SWITCH IS LOCKED IN "OFF" POSITION AFTER REMOVING SWITCH KEY. WARNING: BEFORE REMOVING SWITCH KEY, UNPLUG YOUR JOINTER-PLANER. FAILURE TO UNPLUG JOINTER-PLANER COULD RESULT IN ACCIDENTAL STARTING CAUSING SERIOUS INJURY.

To turn Jointer-Planer "on" after it has been locked in the "off" position, the switch key must be replaced in the switch. WARNING: BE SURE SWITCH IS IN THE "OFF" POSITION BEFORE PLUGGING JOINTER-PLANER IN.

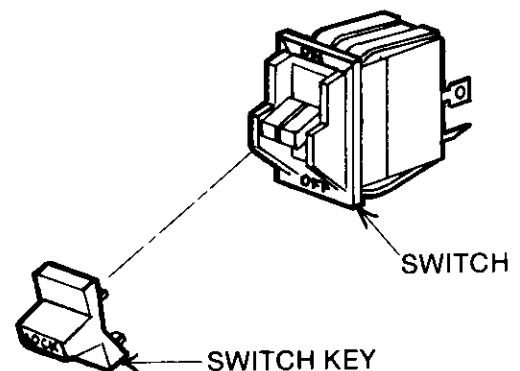

BASIC JOINTER—PLANER OPERATION

For your safety do not exceed a 1/16" deep cut on a planing operation for work pieces wider than 1-1/2". For work pieces less than 1-1/2", a 1/8" cut can be taken at a slow feed rate.

This Jointer-Planer is designed with a special cutter head and internal baffle that blows the sawdust and chips from the rear of the machine. To keep this system operating properly, the motor speed should be maintained. A feed rate that is too fast will slow the motor down resulting in a poor cut and poor chip discharge. The type of wood, wood grain, and moisture content of the wood all affect an acceptable feed rate.

CAUTION: MAKE SURE ALL SIX BLADE LOCKING SCREWS ARE TIGHTENED SECURELY BEFORE ATTEMPTING TO TURN THE MACHINE "ON" OR ATTEMPTING ANY OPERATION.

For your own safety, ALWAYS use hold down/push blocks when JOINTING wood that is NARROWER than 3 in... or when PLANING wood that is THINNER than 3 in.

Do not plane, joint or bevel wood shorter than 12 in. Material this short is more difficult to control while being cut. Small pieces of wood can tip over on the tables or into the cutterhead and can be kicked back toward you.

For best results, take light cuts. For average planing, jointing, or beveling, a cut between 1/32 and 1/16 in. deep will produce the best results.

FEEDING THE WORK PIECE

Hold the board firmly DOWN on both tables and AGAINST the fence... keep fingers close together.

Feed the board at a continuous even rate of speed until the cut is made along the entire length of the board. Any hesitation or stopping could cause a "step" to be cut on the edge of the board which would cause the board to ride up on the outfeed table resulting in a "crooked" edge on the board.

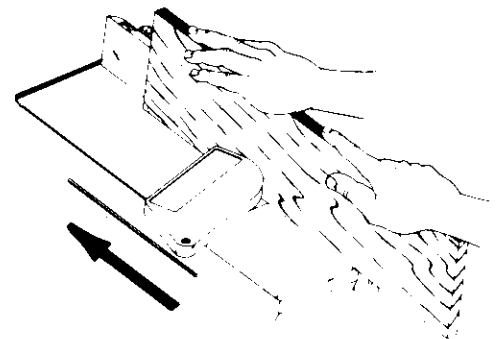
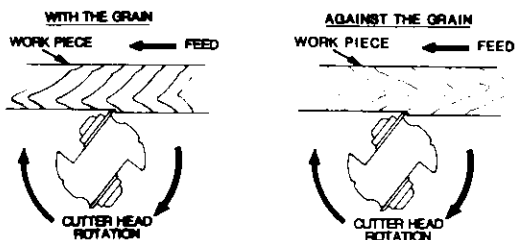

Always feed WITH THE GRAIN whenever possible. If the nature of the work piece is such that it must be fed AGAINST THE GRAIN, take very light cuts and feed slowly.

Start with the left hand in the forward position. As the RIGHT hand passes over the cutterhead, remove the LEFT hand... CONTINUE feeding while placing the LEFT hand behind the RIGHT. Continue feeding in this manner "hand over hand," until the entire length of the board is cut. Pressure should be applied over the cutterhead and outfeed table.

DO NOT FEED TOO FAST. A slow steady rate of feed produces a smooth accurate cut. Feeding too fast causes a "rippled" cut... makes it difficult to guide the workpiece accurately and could be hazardous.

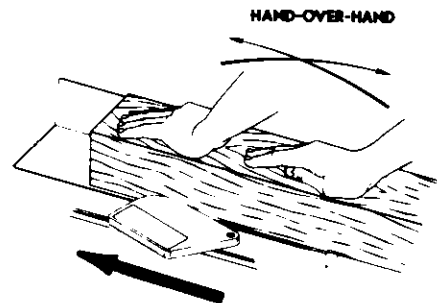

WARNING: NEVER PLACE THE HEEL OF YOUR HAND AT THE END OF THE WORK PIECE WHEN FINISHING A CUT. THIS COULD RESULT IN YOUR HAND COMING IN CONTACT WITH THE CUTTER CAUSING SERIOUS INJURY.

At the end of the cut, position your hand on TOP NEAR THE END of the work piece and continue feeding the work piece until the cutter guard has returned to its closed position.

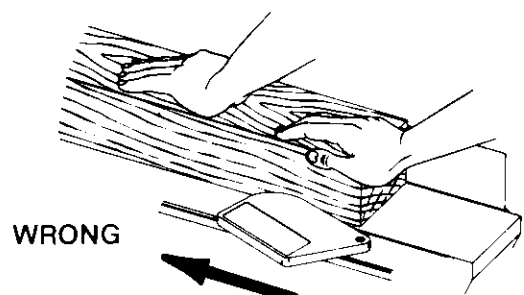
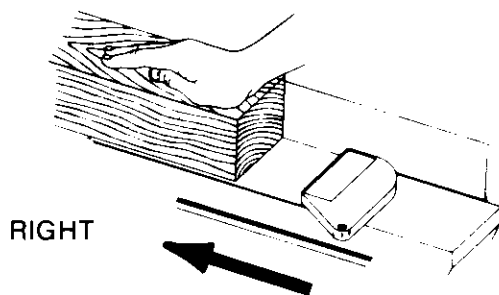

USING HOLD DOWN/PUSH BLOCKS

ALWAYS use the hold down/push blocks when JOINTING wood that is **NARROWER** than 3 in. or PLANING wood that is **THINNER** than 3 in.

Grasp the hold down/push blocks firmly with the fingers close together and wrapped around the handle. Position them flat on top of workpiece, and push the workpiece down against the table to provide a quality cut and minimize the chance of a kickback.

Hold down pressure must be sufficient to prevent hold down/push block from sliding or slipping on the surface of the work piece when advancing work piece over cutter head.

Use a hand-over-hand motion of the hold down/push blocks being careful to maintain control of the workpiece at all times.

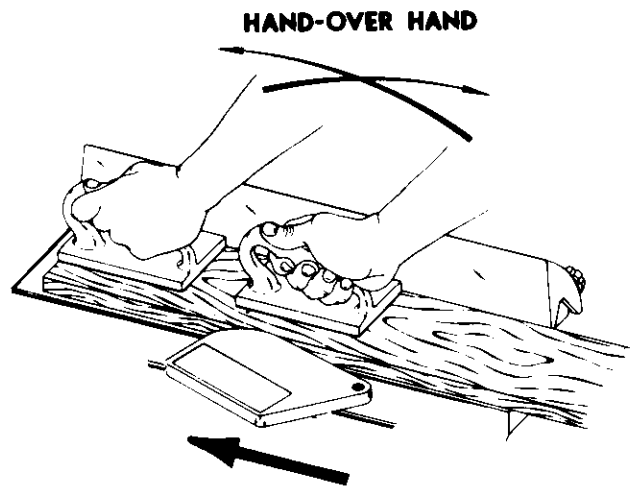

This means that once the work piece has passed the cutter head onto outfeed table, one hold down/push block must always maintain contact with the work piece with outfeed table.

When planing wood 3/4 in. thick and **NARROWER** than the hold down/push block, tilt the hold down/push block so that it clears the top of the cutter guard while feeding.

Never plane wood that is thinner than 1/2 in...because it is apt to split or shatter and thus has a greater tendency to kickback.

 **CAUTION: IF THE HOLD DOWN/PUSH BLOCKS TEND TO SLIP WHILE FEEDING, CLEAN RUBBER SURFACE IMMEDIATELY WITH SANDPAPER.**

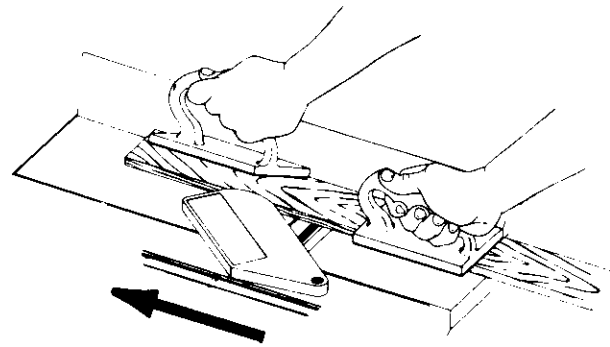

BEVELING AND CHAMFERING

The fence on your jointer-planer is adjustable from 45° inboard to 45° outboard. Adjust the fence to desired angle and tighten lock knobs.

BEVELING is the cutting of an angle on the entire edge of a board. Beveling may require several passes due to the depth of cut needed to bevel entire edge of board.

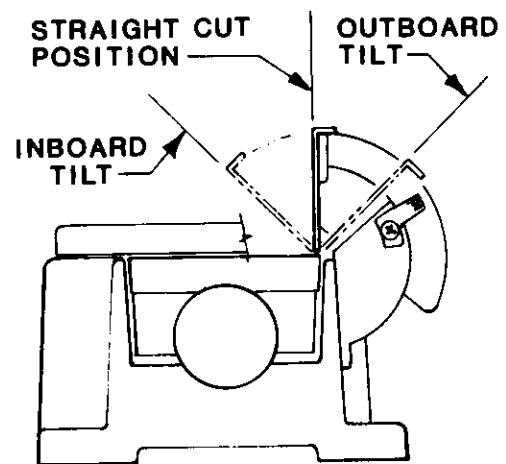
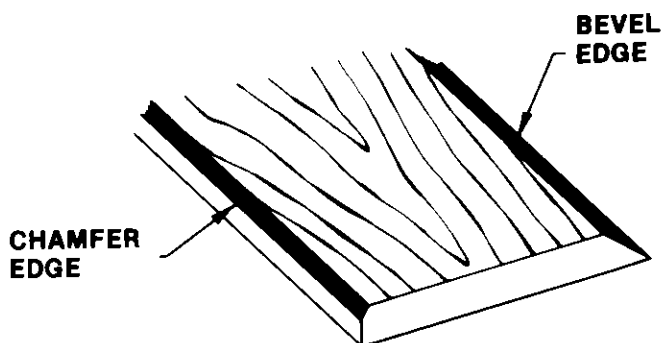

CHAMFERING is removing only the corner of the edge of a board. Normally a chamfer is made with one cut; therefore, a cut deeper than 1/16" may be made.

For beveling and chamfering operations, follow the same procedure as for jointing and planing described on pages 10 and 11. Before performing these operations make sure the surface of the work piece that contacts the fence is flat and smooth. Maintain firm control of the work piece at all times holding it firmly against fence surface and table surfaces.

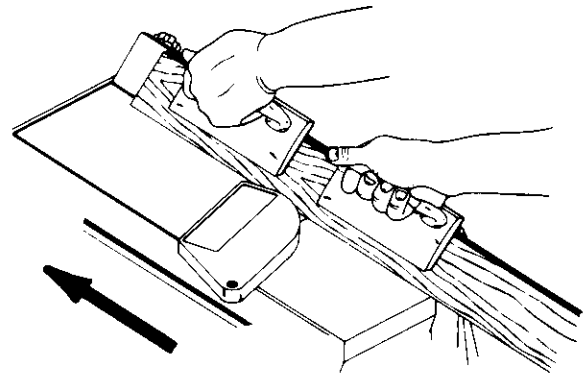
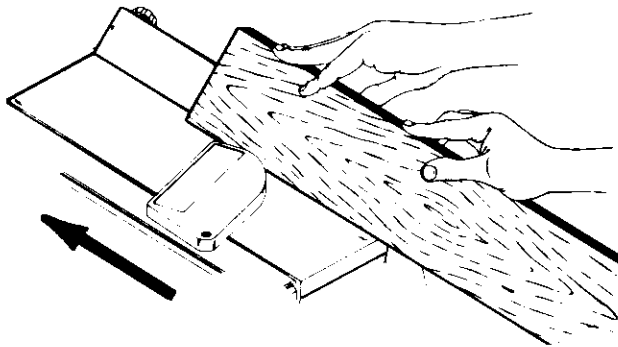

Use hold down/push blocks for wood under 3 in. wide. Position them so you have control of the work piece at all times and so they do not contact the guard or the cutter head.

USING A WET—DRY VAC

Your Jointer-Planer has a rear chip exhaust which fits all Craftsman Wet-Dry Vacs with a 2-1/2 inch hose. A 2-1/2 in. to 1-1/4 in. hose adapter is supplied with the machine for 1-1/4 in. hose connections. Attaching a Craftsman Wet-Dry Vac will keep your work area cleaner. Craftsman Wet-Dry Vacs are available at Sears Catalog and Retail Stores.

WARNING: DO NOT REMOVE CHIP DEFLECTOR EVEN IF VACUUM HOSE REMAINS PERMANENTLY ATTACHED TO MACHINE. NEVER LEAVE HOSE ON MACHINE DURING OPERATION IF A VAC IS NOT USED DURING OPERATION OR THE HOSE AND MACHINE WILL CLOG WITH CHIPS.

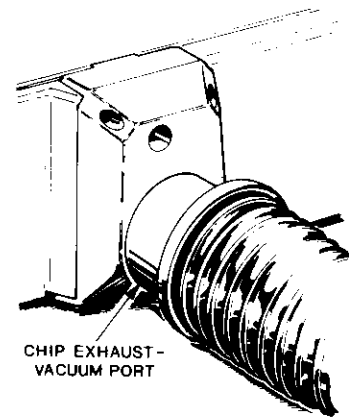

CHIP EXHAUST—VACUUM PORT

MAINTENANCE

TIMING BELT REPLACEMENT

1. Unplug your Jointer-Planer and put switch in OFF position.

DANGER: FAILURE TO UNPLUG YOUR JOINTER—PLANER COULD RESULT IN ACCIDENTAL STARTING CAUSING SERIOUS INJURY.

2. Remove access cover plate by loosening two pan head screws under the machine and one located under the cutter guard, being careful not to damage or disconnect the switch wiring. DO NOT remove cutter guard or guard spring from access cover.
3. Remove old timing belt by turning belt and maintaining outward pressure.
4. Replace with new timing belt by turning belt and maintaining inward pressure. NOTE: Make sure full width of belt is on both pulleys.

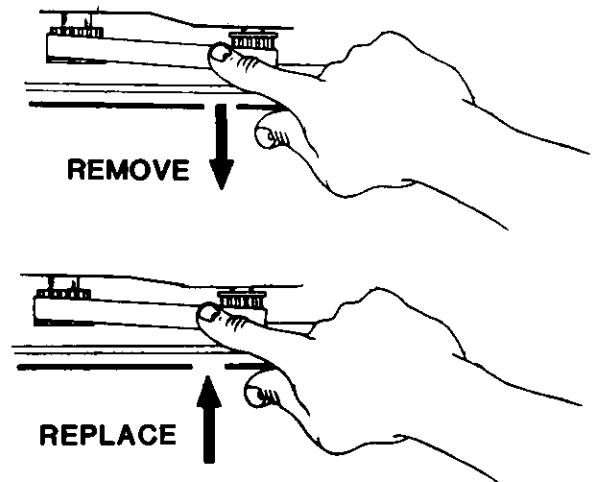

CUTTER GUARD RETURN SPRING

WARNING: DO NOT LUBRICATE THE PIVOT POINT OF THE CUTTER GUARD.

Oil and lubricating products may contain chemicals that can damage and/or destroy the cutter guard or other plastic parts.

CAUTION: IF THE CUTTER GUARD FAILS TO OPERATE PROPERLY (SEE "CONTROLS AND ADJUSTMENTS" SECTION), THE CUTTER GUARD RETURN SPRING WILL NEED REPLACING. CONTACT YOUR NEAREST SEARS STORE OR SERVICE CENTER FOR REPLACEMENT SPRING AND INSTRUCTIONS BEFORE USING THE JOINTER—PLANER.

BLADE REPLACEMENT AND ADJUSTMENT

NOTE: To rotate the cutterhead or to hold it steady, use a screwdriver in the slot in the cutter shaft through the small hole in the rear of the machine just above the vacuum port.

1. Unplug your Jointer-Planer and put switch in off position.
DANGER: Failure to unplug your Jointer-Planer could result in accidental starting causing serious injury.
2. Block the cutter guard open.
3. Using the 5/32" hex key (Allen wrench), remove the three (3) blade lock screws securing blade and blade clamp.
4. Lift blade and blade clamp from cutter head.

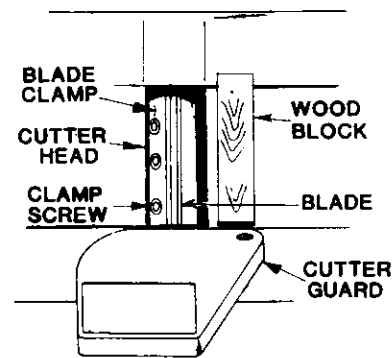

5. Clean any sawdust from cutterhead and any parts you have removed.
6. Place blade clamp against the replacement blade and replace in cutterhead with the (3) blade lock screws. NOTE: Retighten blade lock screws so that the blade is held by friction but still allows for blade movement.
7. Place a straight edge across the outfeed table and across the cutterhead opening.
8. Rotate the cutterhead until the blade contacts the straight edge (rotate backwards to prevent damage to the cutting edge). A properly adjusted blade will lightly tick (touch) the straight edge.

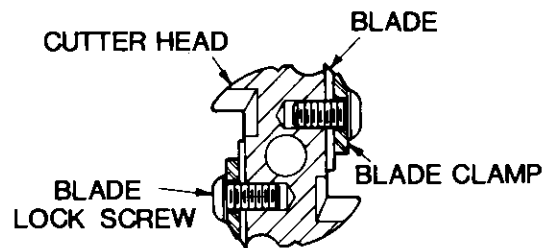

NOTE: Check blade height at both ends of blade. After the first one is adjusted, repeat for second blade.

9. **BLADE TOO HIGH:** If the straight edge is lifted by the blade, it must be lowered. Tap the blade lightly with a scrap piece of wood to lower it.
10. **BLADE TOO LOW:** If the blade does not touch the straight edge, it should be raised. Pry the lower edge of the blade with a screwdriver against the edge of the outfeed table. Always protect the edge of the table with a scrap of wood or piece of cardboard.
11. Tighten blade lock screws.
12. Recheck blade adjustment, making sure blade is still level with outfeed table.
13. Recheck screws to be sure they are secure.



DANGER: FAILURE TO TIGHTEN BLADE LOCK SCREWS COULD RESULT IN SERIOUS INJURY.

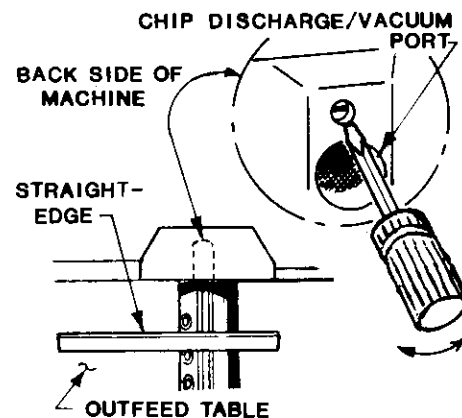

GENERAL MAINTENANCE

Keep your Jointer-Planer clean and adjusted properly for maximum performance and longevity of the machine. Do not allow pitch to accumulate on the tables, fence, cutter guard, or blades. Clean them frequently.



WARNING: DO NOT AT ANY TIME LET BRAKE FLUIDS, GASOLINE, PENETRATING OILS, ETC. COME IN CONTACT WITH PLASTIC PARTS. THEY CONTAIN CHEMICALS THAT CAN DAMAGE AND/OR DESTROY PLASTICS.

DO NOT allow anything to obstruct the chip discharge outlet or disturb the air flow produced by the cutter head.

If the chip discharge of your Jointer-Planer clogs with chips, turn the switch OFF and UNPLUG the unit to avoid accidental starting. Dislodge the chips and debris with a pencil or small wood dowel. When resuming operation with the same work piece, feed at a slower rate to avoid re-clogging. Use of a Wet-Dry Vac will virtually eliminate the chances of clogging.

CRAFTSMAN 4-1/8 INCH JOINTER-PLANER MODEL No. 149.236220

REPAIR PARTS

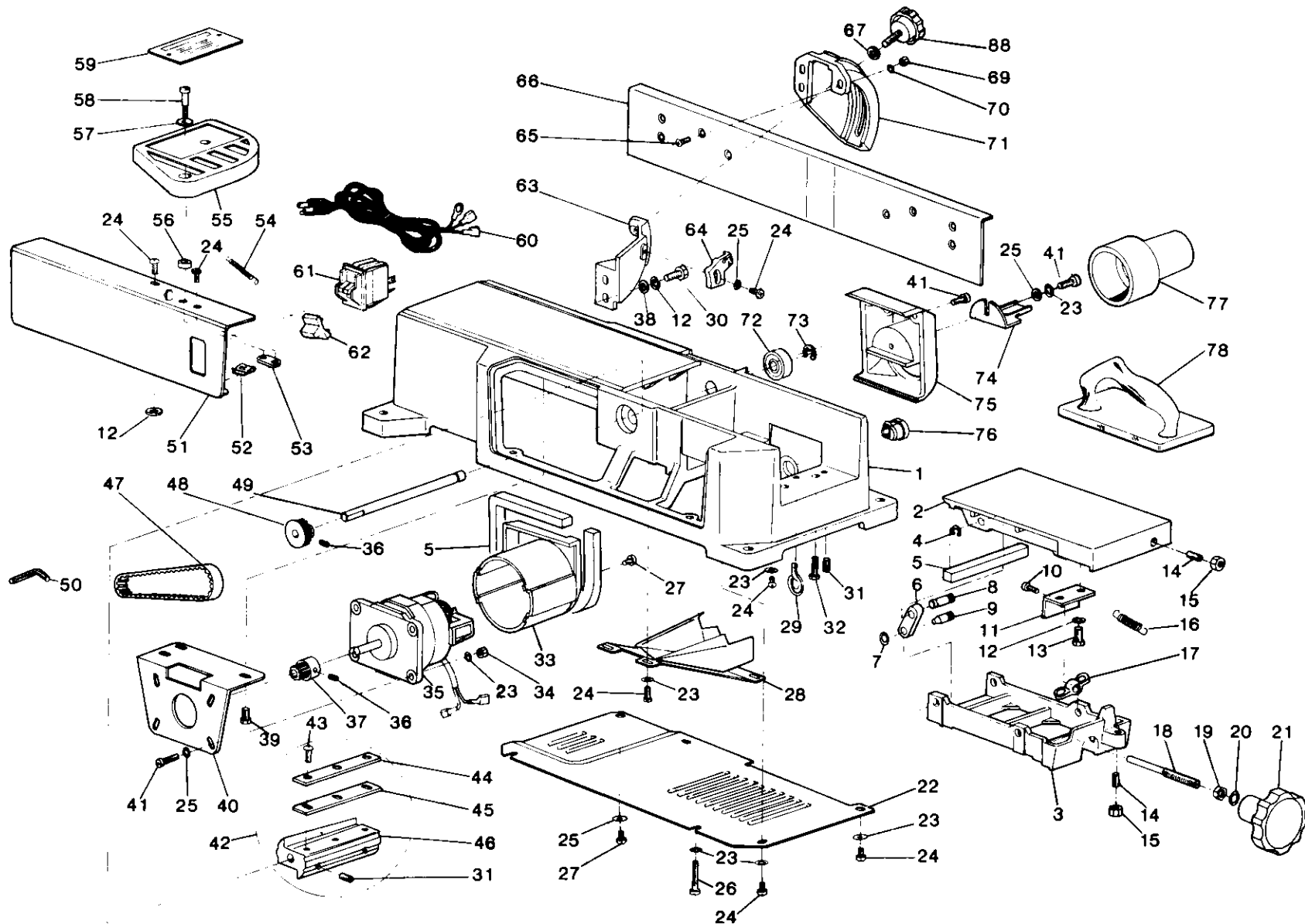

CRAFTSMAN 4—1/8 INCH JOINTER — PLANER MODEL No. 149.236220

PARTS LIST

REF. NO.	PART NO.	DESCRIPTION	QTY.
1	2292.01	Base	1
2	2292.02	Infeed Table	1
3	2292.03	Table Frame	1
4	2292.46	8mm Shaft "E" Clip	4
5	---	3/8 W x 5/16 Foam Gasket	
6	2292.09	Rocker Link	4
7	1791.01	11/32 ID x 9/16 OD x 1/32 Washer	4
8	2292.08	Table Rocker Pin	4
9	2292.07	Hinge Pin	4
10	1705.04	*#10-24 x 5/8 Hex Machine Screw, STD 511005	1
11	2292.38	Table Height Bracket	1
12	1789.02	*1/4 Split Lock Washer, STD 551125	7
13	1715.00	*1/4-20 x 1/2 Hex Cap Screw, STD 522505	2
14	1725.01	*1/4-20 x 3/4" Socket Set Screw	2
15	1773.00	*1/4-20 Hex Nut, STD 541025	2
16	2292.40	Table Spring	1
17	1781.11	3/8"-16 Wing Nut, STD 541637	1
18	2292.39	Height Adjust Screw	1
19	1781.10	*3/8-16 Hex Jam Nut, STD 541237	1
20	1793.01	*3/8 Lock Washer, STD 551237	1
21	2292.30	Table Height Knob	1
22	2292.04	Bottom Cover	1
23	1787.02	*#10 Lockwasher, STD 551210	14
24	1705.06	*#10-24 x 3/8 Pan Head Machine Screw, STD 511003	11
25	1786.00	*#10 Flat Washer, STD 551010	8
26	1705.05	*#10-24 x 1-1/4 Pan Head Machine Screw	2
27	1699.01	*#8 x 3/8 Type B Pan Head Screw	3
28	E2292.42	Chip Chute/Baffle	1
29	2292.45	Table Spring Eye Bolt	1
30	1725.00	*1/4-20 x 3/4 Hex Cap Screw, STD 522507	4
31	1714.00	*1/4-20 x 1/2 Socket Set Screw, STD 502505	6
32	1726.03	1/4-20 x 1" Hex Cap Screw, STD 522510	4
33	2292.15	Motor Housing	1
34	1772.11	*#10-24 Hex Nut, STD 541010	4
35	2292.43	Motor (Northland #73512)	1
36	1703.04	*#10-24 x 5/16 Socket Set Screw, STD 501002	2
37	2292.21	*Motor Pulley	1
38	1791.03	*1/4" Flat Washer, STD 551025	4
39	1715.04	*1/4-20 x 1/2 Hex Flange Screw	3
40	2292.31	Motor Bracket	1
41	1705.07	*#10-24 x 3/4 Pan Head Machine Screw, STD 511007	7

REF. NO.	PART NO.	DESCRIPTION	QTY.
42	E2292.23	Cutterhead Assembly, includes Ref Nos. 43-46 Below	1
43	2292.27	1/4"-20 x 1/2" Socket Button Head Screw	6
44	2292.26	Blade Clamp	2
45	2292.25	Blade	2
46	2292.24	Jointer Cutterhead	1
47	2292.32	XL 120 3/8 W x 12" L Timing Belt	1
48	2292.29	Machine Pulley	1
49	2292.12	Cutter Shaft	1
50	2288.00	5/32 Hex Key (Allen Wrench)	1
51	2292.06	Access Cover Plate	1
52	1772.20	"J" Nut (Tinn. #C8115-1024-4)	2
53	2292.37	Plate Nut (2 #10-24 Holes, 3/4 Centers)	1
54	2292.35	Guard Return Spring	1
55	2292.33	Cutter Guard	1
56	2292.36	Guard Spacer	1
57	2292.51	.260" ID x .440" OD Wave Washer	1
58	2292.50	1/4" x 1/2 Shoulder Bolt, Slotted	1
59	2292.34	"Danger" Plate	1
60	2292.11	6'-10" 18/3 SJT Cord	1
61	2292.05	Switch (includes Ref. no. 62)	1
62	2292.58	Switch Key (order for Key only)	1
63	2292.16	Fence Bracket	2
64	2292.17	Tilt Indicator	2
65	1699.10	*#8-32 x 1/2 Flat Head Machine Screw	6
66	2292.20	Fence	1
67	1791.02	9/32 ID x 17/32 OD x 1/8 Washer	2
68	2292.19	1/4-20 x 1 Lock Knob	2
69	1770.00	*#8-32 Hex Nut, STD 541008	6
70	1787.04	*#8 Flat Washer, STD 551008	6
71	2292.18	Fence Segment	2
72	2292.28	*10mm x 30mm Ball Bearing, Double Seals (#6200Z), STD 315205	2
73	2292.48	10mm Shaft Retaining Ring	1
74	2292.13	Chip Deflector	1
75	2292.14	Chip Discharge	1
76	2292.10	Strain Relief Bushing (Heyco #1214)	1
77	2292.44	2-1/2 Male x 1/4 Female Vac. Adapter	1
78	2292.47	Push Blocks (order No. 2299)	2
--	OM31.01	Owners manual (not illustrated)	
--	E2292.57	Parts bag (not illustrated, see list on pg. 4)	

TROUBLE SHOOTING CHART

TROUBLE	PROBABLE CAUSE	REMEDY
Wood strikes outfeed table after passing over cutterhead	<ol style="list-style-type: none"> 1. Blades improperly adjusted below surface of outfeed table. 2. Infeed table out of adjustment 	<ol style="list-style-type: none"> 1. Re-adjust blades. 2. Contact your nearest Sears store or service center.
Ripples on planed surface.	<ol style="list-style-type: none"> 1. One blade set higher than other. 2. Dull blades. 3. Board not held firmly against fence or outfeed table 	<ol style="list-style-type: none"> 1. Re-adjust blades 2. Re-sharpen or replace. 3. Hold board firmly against fence and outfeed table.
Planed surface not straight.	<ol style="list-style-type: none"> 1. Infeed table loose or cut of adjustment. 2. Blades set too low. 	<ol style="list-style-type: none"> 1. Adjust infeed table, see Maintenance section. 2. Re-adjust blades.
Excessive gouging at end of cut.	<ol style="list-style-type: none"> 1. Blades set too high above outfeed table. 	<ol style="list-style-type: none"> 1. Reset blades.
90° and 45° cuts inaccurate	<ol style="list-style-type: none"> 1. Fence and tilt indicators not adjusted properly. 	<ol style="list-style-type: none"> 1. Re-adjust fence, see Assembly section.
Cutter guard does not function properly.	<ol style="list-style-type: none"> 1. Return spring broken, or spring has been weakened. 	<ol style="list-style-type: none"> 1. Replace spring immediately. Contact your nearest Sears store or service center.
Chip discharge clogs	<ol style="list-style-type: none"> 1. Obstruction reducing air flow. 2. Cutter head speed too slow. 3. Wood has high moisture content. 	<ol style="list-style-type: none"> 1. Remove obstruction. 2. Decrease feed speed. 3. Decrease feed speed.
Cutter slows down during operation	<ol style="list-style-type: none"> 1. Work feed speed too fast. 2. Attempting to remove too much material 	<ol style="list-style-type: none"> 1. Decrease feed speed. 2. Decrease depth of cut, make two or more cuts.

SEARS **owners** **manual**

Service

MODEL NO.
149.236220

How To Order
Repair Parts

SEARS / CRAFTSMAN®

4 1/8-INCH JOINTER-PLANER

Now that you have purchased your Jointer-Planer, should a need ever exist for repair parts or service, simply contact any Sears Service Center and most Sears, Roebuck and Co. stores. Be sure to provide all pertinent facts when you call or visit.

WHEN ORDERING REPAIR PARTS, ALWAYS GIVE THE FOLLOWING INFORMATION:

- | | |
|-------------------------------|-----------------------------------|
| • PART NUMBER | • PART DESCRIPTION |
| • MODEL NUMBER:
149.236220 | • NAME OF ITEM:
JOINTER—PLANER |

All parts listed may be ordered from any Sears Service Center and most Sears stores.

If the parts you need are not stocked locally, your order will be electronically transmitted to a Sears Repair Parts Distribution Center for handling.

SEARS, ROEBUCK AND CO., Dept. 698/731A, Sears Tower, Chicago, IL 60684

42
on diagram

Image not available
Number: E2292.23

 We're sorry. This part is no longer available. No alternate or substitute part has been recommended by the manufacturer.

43
on diagram

Image not available
Blade screw
Number: 2292.27
Substitution: 2292-027-00
Size: 0.70L x 0.80W x 0.80H

\$2.16
In stock
Quantity:

 **Manufacturer authorized substitution:** 2292-027-00 may differ in appearance, but is a functional equivalent to prior parts including 2292.27.

Add to cart

44
on diagram

Image not available
Blade clamp
Number: 2292.26

 We're sorry. This part is no longer available. No alternate or substitute part has been recommended by the manufacturer.

45
on diagram

Image not available
Blade
Number: 2292.25

 We're sorry. This part is no longer available. No alternate or substitute part has been recommended by the manufacturer.

46
on diagram

Image not available
Jointer cutterhead
Number: 2292.24

 We're sorry. This part is no longer available. No alternate or substitute part has been recommended by the manufacturer.

47
on diagram

Image not available
Timing bel
Number: 2292.32
Substitution: DP229203200

\$6.50
In stock
Quantity:

 **Manufacturer authorized substitution:** DP229203200 may differ in appearance, but is a functional equivalent to prior parts including 2292.32.

Add to cart

48
on diagram

Image not available
Machine pulley
Number: 2292.29

 We're sorry. This part is no longer available. No alternate or substitute part has been recommended by the manufacturer.

49
on diagram

Image not available
Cutter shaft
Number: 2292.12