

NO. 227-BM

**ELECTRIC HOLLOW-
CHISEL MORTISER**

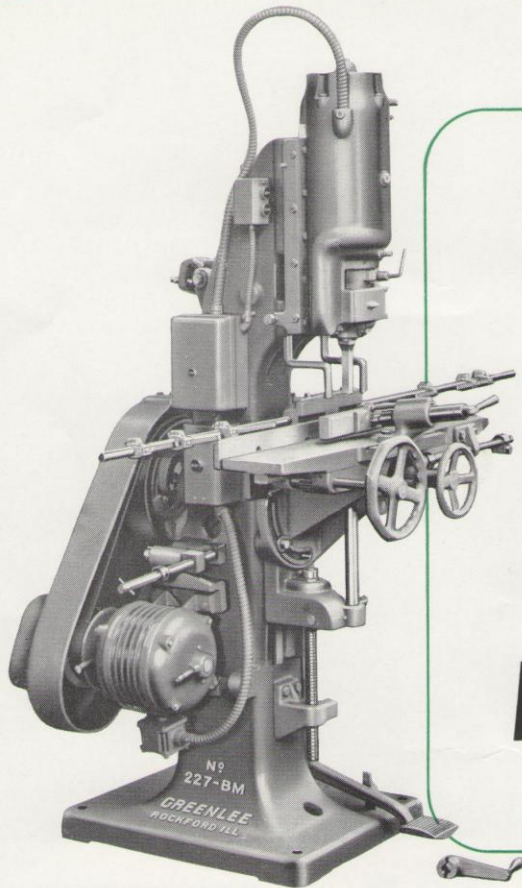

GREENLEE BROS. & CO., ROCKFORD, ILLINOIS, U. S. A.



Greenlee
NO. 227-BM
ELECTRIC
HOLLOW-CHISEL
MORTISER

In 1876, the first successful hollow-chisel mortiser was developed by Greenlee Bros. & Co. The instant success of this first machine marked the real starting point in the machinery manufacturing career of its builders. This first mortiser also introduced a revolutionary new method of mortising that has greatly influenced production in the woodworking field.

Since 1876, Greenlee has made many improvements over the original machine and has maintained leadership in this field, not only in respect to machines but tools as well. Greenlee mortising equipment has always been known for accuracy, speed, and economical operation.

The No. 227-BM variable power-feed mortiser described in this bulletin is ideal for general work in furniture, sash, door, and similar manufacturing. The 227-BM is regularly rated for chisels up to 1-inch square, but can handle 1-1/4 or 1-1/2-inch chisels for relatively shallow mortising in soft wood when the machine is so ordered.

The machine is sturdily constructed and its design embodies many important features which increase the mortiser's value as a production tool. A flexible power stroke, which can be started or stopped instantly, feeds the mortising tool to the work. Variable feed is provided so that a wide range of strokes per minute can be selected to fit the work requirement. Anti-friction bearings are used throughout the machine, proper tool holders are provided, and an air blast removes chips from the working area and also cools the mortising tools.

FRAME CONSTRUCTION

The frame consists of a strong one-piece casting with a heavy base and accurately machined ways for the chisel carriage and table knee. The ways are machined at the same setting to insure correct alignment and permanent accuracy. With exception of the drive pulley, which is belt-driven from the feed motor, the entire feed mechanism is enclosed within the frame.

CHISEL CARRIAGE

The chisel carriage fully encloses the ball-bearing bit spindle, which has ball-bearing thrust and on which is mounted the built-in motor. The carriage is moved up and down on gibbed ways by the power-feed mechanism. To facilitate tool changing, a cast-iron door is provided at the bit fastening, making tool changes a simple and rapid operation. Adjustable thrust bit bushings maintain correct relation between the bit and chisel. The spindle also has a hand brake for quick stopping.

The 227-BM can be furnished with a bit extension for occasional boring jobs, or even with clusters for boring more than one hole at a time. A blower within the carriage provides forced ventilation for the built-in motor as well as an air blast for chip removal and cooling the mortising tools.

FEED

The power-feed mechanism consists of an enclosed worm and worm-gear drive, mounted in ball-bearings and running in oil, which operates the chisel carriage through a crank, connecting link, and a lever. Instant starting and stopping is made possible through the use of multiple-disk clutch mounted in a roller-bearing pulley, which is belted from the feed motor through a variable-feed mechanism. When the clutch is disengaged, the movement of the chisel carriage is stopped instantly at any point in its stroke.

The clutch disks are made of hardened steel, thus reducing wear to the absolute minimum. In addition, the shifter lever is never in contact with the spider when the clutch is running, eliminating any wear at that point.

The feed mechanism is controlled by a convenient foot lever located close to the floor. The operator can work the lever with the ball of his foot while resting his heel on the floor. Jogging of the feed is possible for extremely difficult work. The foot lever has a hold-down lock for use when continuous mortising strokes are desired.

The variable feed provides for any number of chisel strokes from 17 to 52 per minute as standard, but arrangements can be made for increasing the number to 70 or more for some soft wood mortising. A screw arrangement on the feed lever permits stroke adjustment from 2½ to 4 inches. The lever is graduated to indicate the exact setting of the stroke. A detachable crank is used for this adjustment as well as for changing the rate of feed and height of the table.

TABLES

Two styles of tables can be furnished with this mortiser, differing only in adjustment and fittings. Both styles have vertical, tilting, and cross adjustments, but only the compound table has lengthwise movement for making mortises by successive chisel strokes. The compound table is designated by the letter "B". The table's movement is gauged by adjustable stops. The compound table also differs from the plain table in having a workholding clamp. This type of table is recommended for ordinary requirements.

Either of two types of table clamps are available with the machine. The screw clamp, as shown in the illustration below, is regular equipment on the compound table, but the quick-acting lever clamp, shown on page 2, can be substituted. The quick-acting clamp is very efficient, but is not suitable for handling high stock.

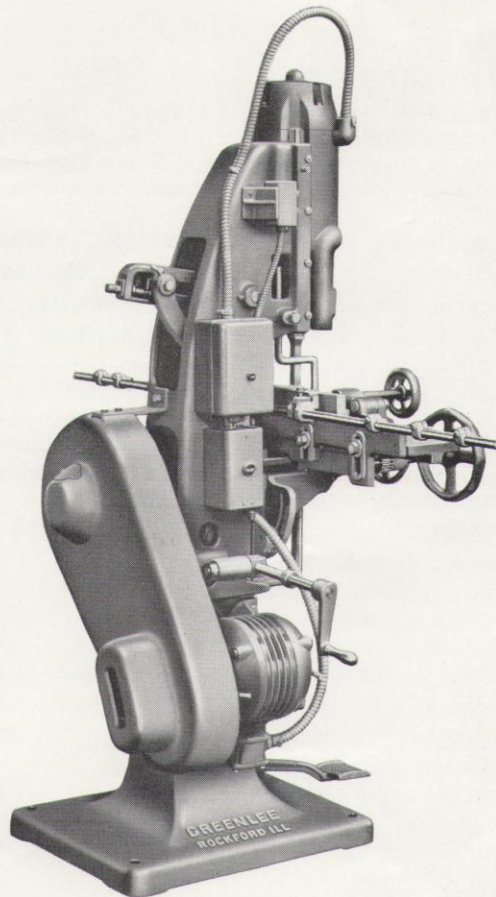

Rear view of No. 227-BM Mortiser showing the guard over the feed pulleys and belt, also the adjustment for the length of mortising stroke.



The standard back fence has vertical adjustment and is fitted with a lip hold-down. Two adjustable prong hold-downs are carried from the machine frame. A special high back fence can be furnished to handle stock up to 14 inches high under the lip. This special attachment is shown in the illustration at the right. It can also be fitted with a detachable screw clamp mounted on top of the fence for holding high stock.

DRIVE

With the exception of the short feed V-belt, which is part of the variable feed mechanism, the No. 227-BM Electric Mortiser is beltless. The bit spindle is driven by the built-in motor, and the feed is by the motor mounted on the machine column. The two motors are entirely enclosed, dust tight, and fan cooled. They also have interlocked wiring and are controlled by one push-button station through a magnetic switch.

SPECIFICATIONS

Each mortiser is regularly equipped with a 1/2 x 4-inch hollow chisel with bit, a set of chisel bushings, adjustable thrust bit bushings, a 6-foot layout stop rod with 6 spring stops, and necessary wrenches.

| | |
|--|--|
| Chisel capacity..... | 1/4" to 1" or up to 1 1/2" if so ordered |
| Chisel stroke..... | 2 1/2" to 4" |
| Maximum distance from chisel socket to table..... | 19" |
| Maximum distance from back fence to chisel center with stop rod in place..... | 5 3/8" |
| Normal distance from back fence to chisel center with clearance for lengthwise table travel..... | 4 1/8" |
| Variable-speed feed for 17 to 52 strokes per minute. (Slower or faster feeds can be provided.) | |
| Table size..... | 6" x 36" |
| Vertical adjustment of table..... | 13" |
| Cross adjustment of table: | |
| With stop rod above ways on column..... | 5 3/8" |
| With stop rod against ways on column..... | 4 1/2" |
| Lengthwise adjustment of compound table..... | 14" |
| Angular adjustment of table..... | 45° |
| Clamping width with screw-type clamp..... | 5 1/2" |
| Maximum height of stock that can be worked under a 4" chisel..... | 14" |
| Totally enclosed spindle motor regularly | |
| 5-H. P. | 3600-R.P.M. |

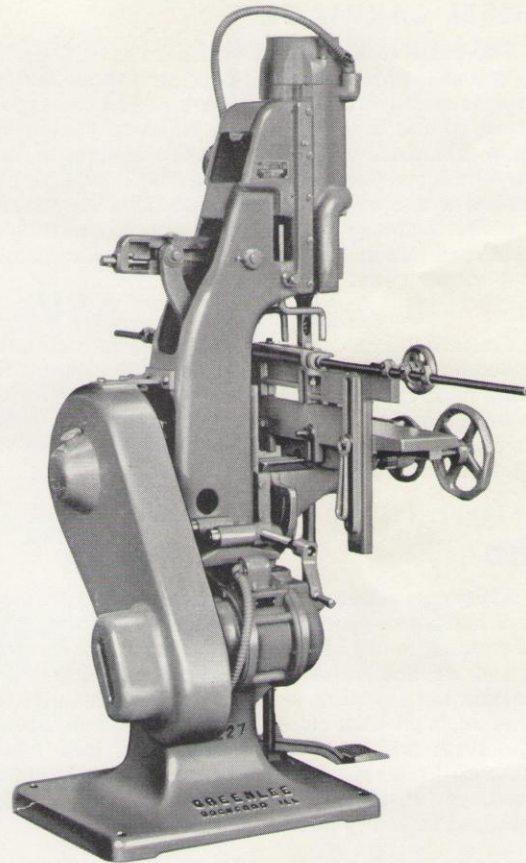

No. 227-BM Mortiser with a special high back fence to handle stock up to 14 inches high.

| | |
|--|-------------|
| Totally enclosed feed motor 1-H. P..... | 1800-R.P.M. |
| Net weight in pounds of No. 227-BM..... | 1450 |
| Net weight in pounds of No. 227-M..... | 1400 |
| Weight boxed for export of No. 227-BM..... | 1900 |
| Box measure in cubic feet of No. 227-BM..... | 59 |

Codes:

| | |
|--|-------|
| No. 227-BM electric machine with compound table..... | CIMUV |
| No. 227-M electric machine with plain table..... | CIMYX |
| Special high back fence substituted..... | CINOV |
| Screw clamp for high back fence..... | CINUX |

GREENLEE BROS. & CO., ROCKFORD, ILLINOIS, U. S. A.

Machinery for Planing, Shaping, Tenoning, Mortising, Boring and Sawing
Tools for Mortising, Boring and Routing

MEMO

—TO

John Schmeling

DATE 4/21/83

Enclosed is a brochure for the 227
Mortiser you requested.

Form No. 394

BY R.D. Duffey