

Model 45

12" LATHE

MAINTENANCE INSTRUCTIONS AND PARTS LIST

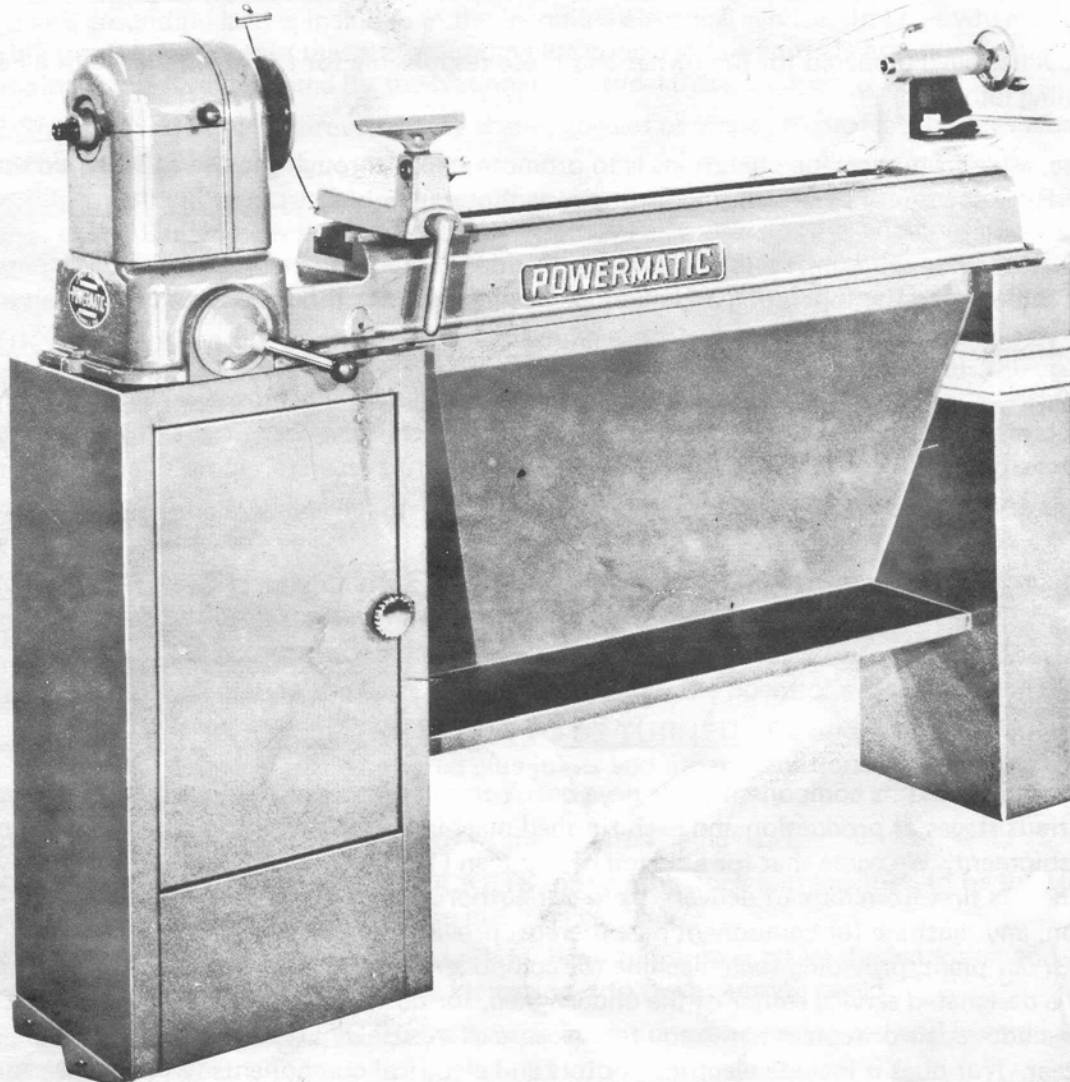

POWERMATIC®

Strength and performance right down the line.

POWERMATIC  HOUAILLE, INC.

McMinnville, Tennessee 37110
AC 615-473-5551

FOREWORD

SAFETY FIRST!

This manual has been prepared for the owner and those responsible for the maintenance of a Powermatic wood-turning lathe.

Its purpose, aside from machine operations is to promote safety through the use of accepted operating practices. Read the safety and operating instructions thoroughly before operating the machine.

In order to obtain maximum life and efficiency from your Powermatic lathe and to aid in operating the lathe with safety, read the operating and maintenance instructions thoroughly and follow all directions carefully.

The specifications listed were in effect when the manual was published. However, because of Powermatic's policy of continuous improvement, Powermatic Houdaille, Inc., reserves the right to change specifications at any time without notice and without incurring obligations.

WARRANTY

This machine and its component parts have been carefully inspected and performance tested at various stages of production and each finished machine is subjected to a final inspection before shipment. We agree that for a period of eighteen (18) months or 3000 hours of use, whichever occurs first from date of delivery from our authorized dealer, to repair or replace, at our option, any machine (or component part thereof) proving defective within the above period, F.O.B. our plant, providing such machine (or component part) is returned prepaid to our plant, or to a designated service center of the undersigned, for our examination. This warranty does not include repair or replacement required because of misuse, abuse, or because of normal wear and tear. Nor does it include electrical motors and electrical components which are warranted by their manufacturer and which should be taken to their local authorized repair station for service. Cost of removal, shipment and reinstallation are not covered hereby. Further, we cannot be responsible for the cost of repairs made or attempted outside of our factory or designated service center without our authorization. No claims will be honored if Serial No. plate has been removed. **THIS WARRANTY IS MADE EXPRESSLY IN PLACE OF ALL OTHER WARRANTIES OR GUARANTEES, EXPRESS OR IMPLIED, WITH RESPECT TO FITNESS, MERCHANTABILITY, QUALITY OR OPERATIVENESS. THIS WARRANTY IS MADE ONLY TO THE ORIGINAL PURCHASER, AND BECOMES EFFECTIVE ONLY WHEN THE ACCOMPANYING CARD IS FULLY AND PROPERLY FILLED OUT AND RETURNED TO THE FACTORY WITHIN TEN (10) DAYS FROM DATE OF DELIVERY.**

POWERMATIC  **HOUDAILLE, INC.**
McMinnville, Tennessee 37110

WOOD LATHE SAFETY INSTRUCTIONS

1. **READ, UNDERSTAND AND FOLLOW** the safety and operating instructions found in this manual. Know the limitations and hazards associated with this Wood Lathe. A safety decal is placed on each machine as a reminder of basic safety practice.
2. **GROUNDING OF THE LATHE:** Make certain that the machine frame is electrically grounded and that a grounding lead is included in the incoming electrical service. In cases where a cord and plug are used, make certain that the grounding lug connects to a suitable ground. Follow the grounding procedure indicated by the National Electrical Code.
3. **EYE SAFETY:** Wear an approved safety shield, goggles or glasses to protect the eyes when operating the wood lathe.
4. **PERSONAL PROTECTION:** Before operating the machine, remove tie, rings, watches, and other jewelry, and roll up sleeves above the elbows. Remove all loose clothing and confine long hair. Protective type foot wear should be worn and hearing protectors should be worn where noise exceeds the level of exposure allowed in section 1910.95 of the OSHA regulations. Do Not Wear Gloves!
5. **WORK AREA:** Keep the floor around the machine clean and free of scrap material, saw dust, oil or grease to minimize the danger of tripping or slipping. Powermatic recommends the use of anti-skid floor strips on the floor area where the operator normally stands. Provide ample unobstructed floor area around the machine. Mark off the machine area. Make certain that the work area is well lighted and that a proper exhaust system is used to minimize dust.
6. **GUARDS:** Keep the machine guards in place, make certain they are operable, and use them at all times.
7. **DON'T OVERREACH:** Maintain a balanced stance and keep your body under control at all times. Do not overreach or use excessive force to perform any operation.
8. **MAINTAIN TOOLS IN TOP CONDITION:** Keep tools sharp and clean for safe and best performance. Dull tools can grab in the work and be jerked from the operator's hands causing serious injury.
9. **CHECK THE CONDITION OF THE STOCK TO BE TURNED:** Be sure it is free of knots, warpage, checked ends, improperly made or cured glue joints and other conditions which can cause it to be thrown out of the lathe.
10. **SECURELY FASTEN SPUR CENTERS** to the material being used.
11. **CHECK CENTERS AND CENTER SOCKETS** in the headstock and tailstock to be sure they are free of dirt or rust and oil lightly before inserting centers.
12. **TEST EACH SETUP** by revolving the work by hand to insure it clears the work rest and bed and check setup at the lowest speed before increasing it to the operating speed.
13. **USE THE CORRECT CUTTING TOOL** for the operation to be performed and keep all tools in a sharpened condition.
14. **USE LOW SPEEDS FOR ROUGHING AND FOR LONG OR LARGE DIAMETER WORK:** If vibration occurs, stop the machine and correct the cause. See Table 1 for speed recommendations.
15. **WHEN SANDING, REMOVE THE TOOL REST FROM THE MACHINE,** apply light pressure, and use a slow speed to avoid heat build up.
16. **WHEN TURNING LARGE DIAMETER PIECES, SUCH AS BOWLS, ALWAYS OPERATE THE LATHE AT LOW SPEEDS.**
17. **NEVER USE DULL TURNING TOOLS** — sharp tools help to prevent the tool grabbing in the work and being jerked from the operator's hands.
18. **TAKE MEASUREMENTS ON THE PART ONLY WITH THE SPINDLE STOPPED.**
19. **DO NOT ATTEMPT TO ENGAGE THE SPINDLE LOCK PIN UNTIL THE SPINDLE HAS STOPPED.** If leaving the machine area, turn it off and wait until the spindle stops before departing.
20. **GIVE THE WORK YOU ARE DOING YOUR UNDIVIDED ATTENTION.** Looking around, carrying on a conversation and "horseplay" are careless acts that can result in serious injury.

WOOD LATHE SAFETY INSTRUCTIONS, cont'd

21. **MAKE NO ADJUSTMENTS EXCEPT SPEED CHANGE WITH THE SPINDLE ROTATING** and always disconnect machine from power source when performing maintenance to avoid accidental starting or electrical shock.
22. **BOLT THE LATHE TO THE FLOOR** through the lag holes provided to avoid any tendency of the lathe to tip or shift during turning operations.
23. **PROVIDE FOR ADEQUATE SURROUNDING WORK SPACE** and overhead non-glare lighting. Powermatic recommends the use of non-skid floor strips on the floor area where the operator normally stands and marking off a work area for each machine.
24. **DON'T STAND IN LINE WITH ANY LARGE DIAMETER PART** being turned **OR ALLOW ANY-ONE ELSE TO DO SO.**
25. When stopping the lathe, **NEVER GRAB THE PART OR FACE PLATE TO SLOW IT DOWN.** Let the work coast to a stop.
26. Use only Powermatic or factory authorized replacement parts and accessories; otherwise, the warranty and guarantee are null and void.
27. **DO NOT USE THIS POWERMATIC WOOD LATHE FOR OTHER THAN ITS INTENDED USE. IF USED FOR OTHER PURPOSES, POWERMATIC DISCLAIMS ANY REAL OR IMPLIED WARRANTY AND HOLD ITSELF HARMLESS FROM ANY INJURY THAT MAY RESULT FROM THAT USE.**

WARNING: DO NOT EQUIP OR USE THIS MACHINE WITH A MOTOR LARGER THAN 3/4 HORSEPOWER AT 1800 RPM. THE USE OF A LARGER OR HIGER SPEED MOTOR VOIDS THE WARRANTY AND POWERMATIC HOLDS ITSELF HARMLESS FROM ANY INJURY THAT MAY RESULT.

MODEL 45 LATHE SPECIFICATIONS

	ENGLISH	METRIC
Swing Over Straight Bed	12"	305mm
Swing Over Gap	16"	406mm
Swing Over Tool Rest	8"	203mm
Width of Gap	4-7/8"	124mm
Width of Gap from Face Plate	3-1/4"	82mm
Distance Between Centers	39"	991mm
Height of Spindle Centering to Floor	42-1/4"	1073mm
Length of Standard Bed	60"	1524mm
Overall Length, Width and Height	63" L. X 16" W. X 46-1/2" H.	1600mm L. X 406mm W. X 1181mm H.
Motor	3/4 Hp.	56 Kw
Speed Range, V.S. Drive	330 - 2100 RPM.	Same
Speed Range, Step Cone Drive	600, 1110, 1800, 3000 RPM.	Same
Shipping Weight Crated	439 lbs.	199Kg

MODEL 45 LATHE - DIMENSIONAL DRAWING

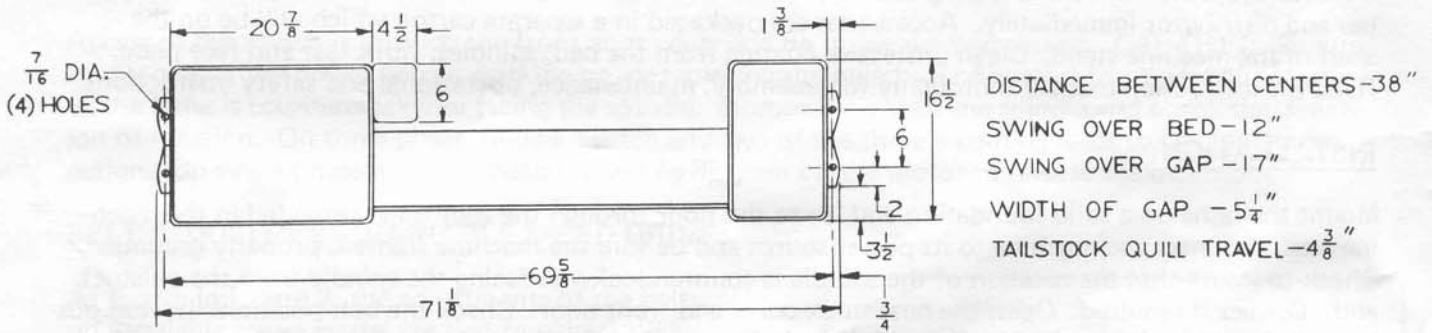

FLOOR PLAN

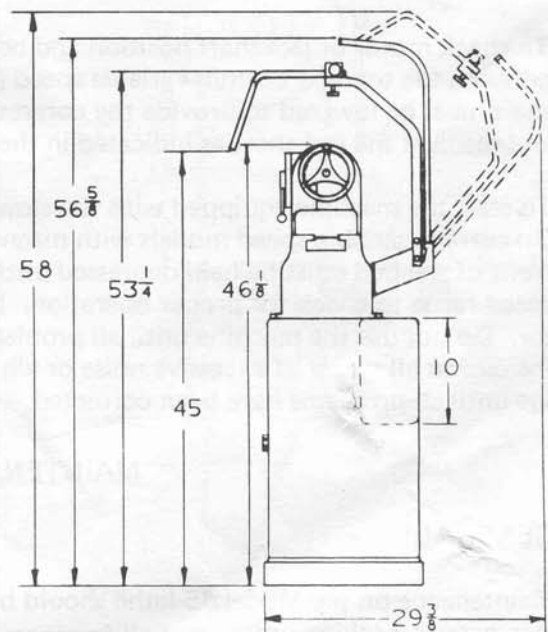
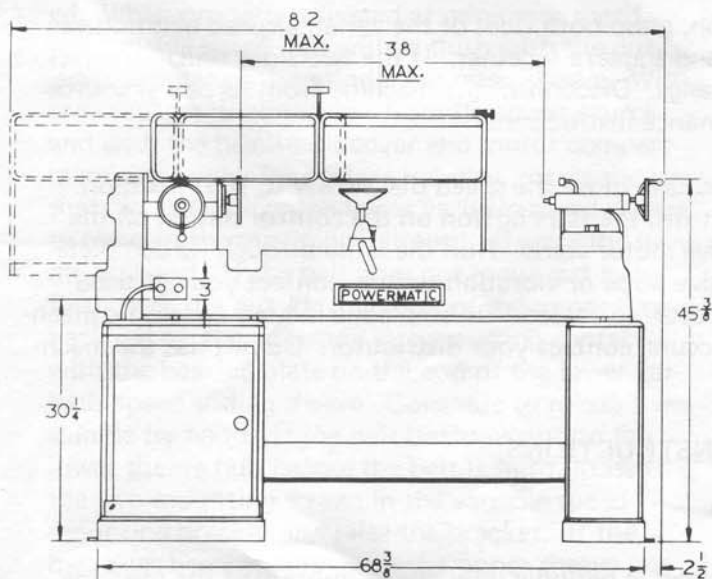

Fig. 1

WOOD TURNING LATHE SPEEDS

DIA. OF WORK	ROUGHING R. P. M.	GEN. CUTTING R. P. M.	FINISHING R. P. M.
Under 2"	1520	3000	3000
2 to 4"	760	1600	2480
4 to 6"	510	1080	1650
6 to 8"	380	810	1240
8 to 10"	300	650	1000
10 to 12"*	255	540	830
12 to 14"	220	460	710
14 to 16"	190	400	620

Fig. 2

MACHINE INSTALLATION, ADJUSTMENT AND MAINTENANCERECEIVING:

Remove the lathe from the shipping container and check for damage. Report any damage to your shipper and distributor immediately. Accessories are packaged in a separate carton which will be on the shelf of the machine stand. Clean protective coating from the bed, spindles, work rest and face plate. Read the instruction manual thoroughly for assembly, maintenance, operational and safety instructions.

INSTALLATION:

Mount the lathe on a solid foundation and lag to the floor through the four holes provided in the machine base. Connect the machine to its power source and be sure the machine frame is properly grounded. Check to insure that the rotation of the spindle is counterclockwise facing the spindle from the tailstock end. Correct if required. Open the headstock cover and front door. Check the belt position. In stop position, it should be flush with the O.D. of the spindle mounted variable speed pulley. If it is not, readjust as indicated in the maintenance instructions.

To check motor or jackshaft position and belt tension, grasp both sides of the variable speed belt midway between the top and bottom variable speed pulleys and squeeze together. If the two sides touch, the jackshaft must be lowered to provide the correct speed range. Disconnect the machine from its power source and readjust the jackshaft as indicated in the maintenance instructions.

To start the machine equipped with the slow start feature, move the speed dial slowly to start position. On current variable speed models with magnetic controls, the start button on the control station on the front of the bed must be held depressed until the drive motor starts. Run the lathe through its complete speed range to check for proper operation. If excessive noise or vibration occurs, contact your distributor. Do not use the machine until all problems have been corrected. On step cone models check the machine out on all steps. If excessive noise or vibration occurs, contact your distributor. Do not use the machine until all problems have been corrected.

MAINTENANCE INSTRUCTIONSGENERAL:

Maintenance on the Model 45 lathe should be performed at periodic intervals to insure that the machine is in proper working order, that all fasteners are tight, and that the machine is in adjustment. The more use the machine is subjected to, the more often it should be inspected and maintained. Inspection and maintenance should be performed at least twice a year.

MAINTENANCE INSTRUCTION, cont'd**GENERAL, cont'd**

CAUTION: Disconnect machine from power source before performing any maintenance on the machine to prevent accidental starting or electrical shock.

MOTOR:

The lathe is equipped with a 3/4 HP, 1800 RPM motor, single or 3 PH mounted to a motor mounting bracket. To inspect or service the motor, open the cabinet door for access to it. Inspect the motor for sawdust accumulation in the motor and surrounding area.

A jackscrew and jam nuts are provided for tensioning the vee belt between the motor and jackshaft assembly. The correct rotational direction of the motor is clockwise facing the shaft end of the motor which will give counterclockwise rotation to the lathe spindle when viewing it from the tailstock end.

MOTOR SWITCH:

The motor switch on step cone versions is mounted in the headstock cabinet base on the right front upper corner. On slow start variable speed models, the motor switch is mounted inside the bed casting and is operated through a switch arm and a cam just behind the variable speed cam mounted on the variable speed cam shaft rotating in a hole in the bed.

Access to the switch is through the front door cover and up inside the bed casting. **CAUTION:** Be sure to disconnect the power before working on, or replacing the switch. The correct rotational direction of the lathe is counterclockwise facing the spindle. Momentarily start the spindle and check the direction of rotation. On three phase models, switch any two of the three incoming leads to change the direction. On single phase models, check the wiring diagram on the motor to reverse the direction.

BELT ADJUSTMENT, VARIABLE SPEED DRIVE:

As shown in Figure 3, the adjustments of the belts on a variable speed model are tied together. Whenever an adjustment is made to the variable speed belt, the lower vee belt will also have to be adjusted. When properly adjusted at minimum speed, the variable speed belt will be flush with the outside diameter of the spindle mounted sheave. With the machine disconnected from its power source and with the headstock cover and motor compartment door open for better visibility, rotate the cam shaft so as to allow the lower variable speed sheave to open to the maximum amount. Rotate the spindle by hand. If the belt does not move out to be flush with the outside diameter of the upper sheave back off on the adjusting screw making contact with the bearing plate on the end of the lower variable speed sliding sheave. Continue to rotate the spindle by hand. If the belt bottoms out on the lower sheave hub before the belt is flush, loosen the two mounting screws in the variable speed mounting bracket and raise the bracket. If the belt does become flush with the upper sheave outside diameter, loosen the mounting screws in the variable speed mounting bracket and back off the adjusting screw. Lower the bracket until the var-

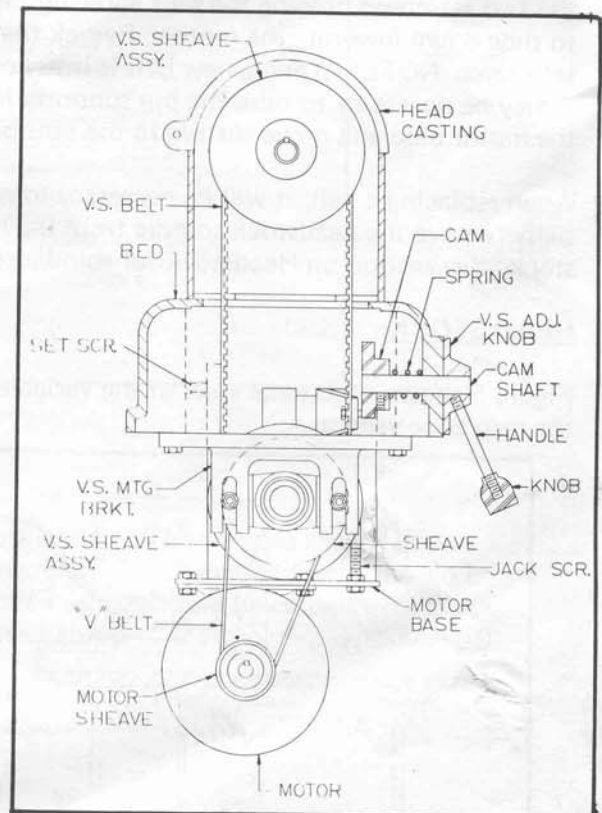

Fig. 3

MAINTENANCE INSTRUCTION, cont'd

BELT ADJUSTMENT, VARIABLE SPEED DRIVE, cont'd

variable speed belt is slightly tight. Raise the bracket about 1/16" and lock in place.

Adjust the adjusting screw in, while rotating the spindle until the belt shows a tendency to move in from the outside diameter of the upper sheave. Lock the adjusting screw in place. Adjust the motor base with its adjusting screw to tension the vee belt between the lower variable speed countershaft and the motor. It may be necessary to raise the motor base in order to raise the lower countershaft. Belt wear or stretch will make belt adjustment necessary periodically.

To change the variable speed belt, the headstock spindle must be removed. See section on Headstock for spindle removal.

BELT ADJUSTMENT, STEP CONE MODELS:

As shown in Figure 4, the belt is released and tensioned through use of a belt tension cam operated from the front of the machine. Open the headstock cover and cabinet door for better visibility. Swing the lever down to the lower position. Check the belt tension. If it is not enough, check in what hole the pin is located on the tension arm. If it is in a position other than the bottom position, pull out the pin and allow the motor to drop down. Raise the tension arm until the pin will go in the next hole and reinstall the pin. Swing lever to lower position and check for proper tightness of the belt. If the pin is in the lower hole, the motor base pin supports will have to be lowered. Loosen the two setscrews holding the pins allowing them to slide down lowering the motor. Relock the two setscrews. NOTE: When a new belt is installed, it may be necessary to raise the pin supports for the motor base and move the pin in the tension arm.

When replacing a belt, it will be necessary to partially remove the headstock spindle from the headstock. See section on Headstock for spindle removal.

HEAD STOCK:

Figure 5 shows a sectional view of the variable speed headstock and Figure 6 shows the same view of the step cone version.

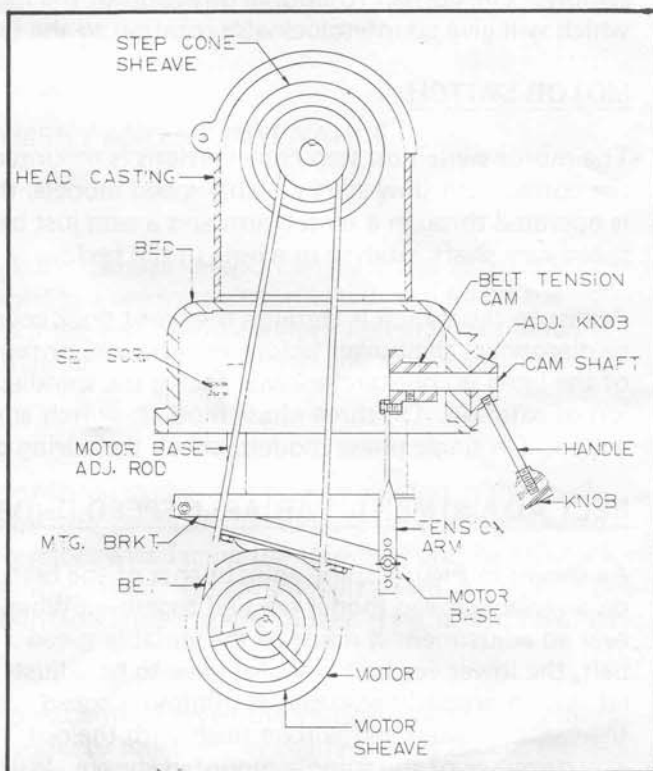

Fig. 4

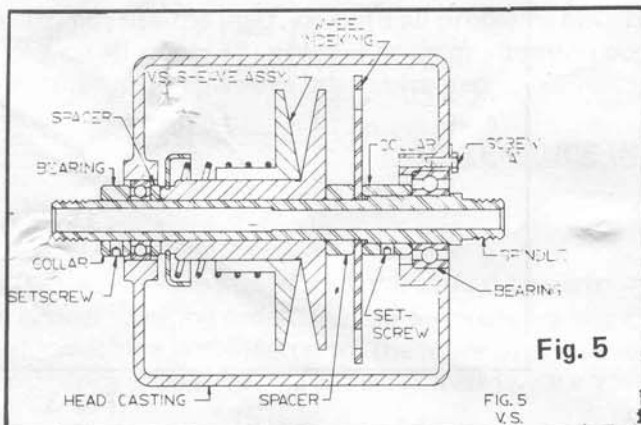

Fig. 5

FIG. 5
V.S.

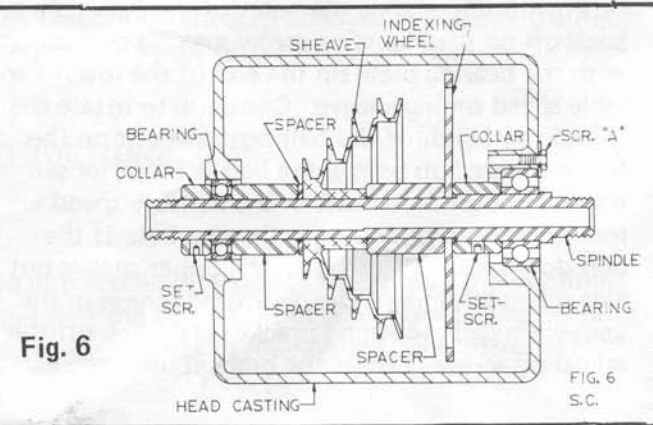

Fig. 6

FIG. 6
S.C.

GENERAL INSTRUCTION, cont'd**HEADSTOCK, cont'd**

To remove the spindle, remove screw "A", loosen the setscrews in the collar at the left hand of headstock, and remove the collar. With a brass rod or piece of soft material and a hammer, tap the spindle to the right until the front bearing comes out of the casting support, the sheave index wheel and spacers, and slide spindle out of the headstock. If the front bearing must be removed, loosen the setscrew in the collar directly behind the bearing and using a collar against the front side of the inner bearing race, press the bearing off the shaft.

TOOL REST:

The tool rest is designed to allow adjustment for height, position on bed and angle to the work. Three blades are available; six inch straight length (std.), 12 inch straight length (opt.) and a right angle style (opt.). Periodically the tool rest should be disassembled and the parts cleaned and oiled to provide free movement of the parts to insure good clamp action. (Fig. 7).

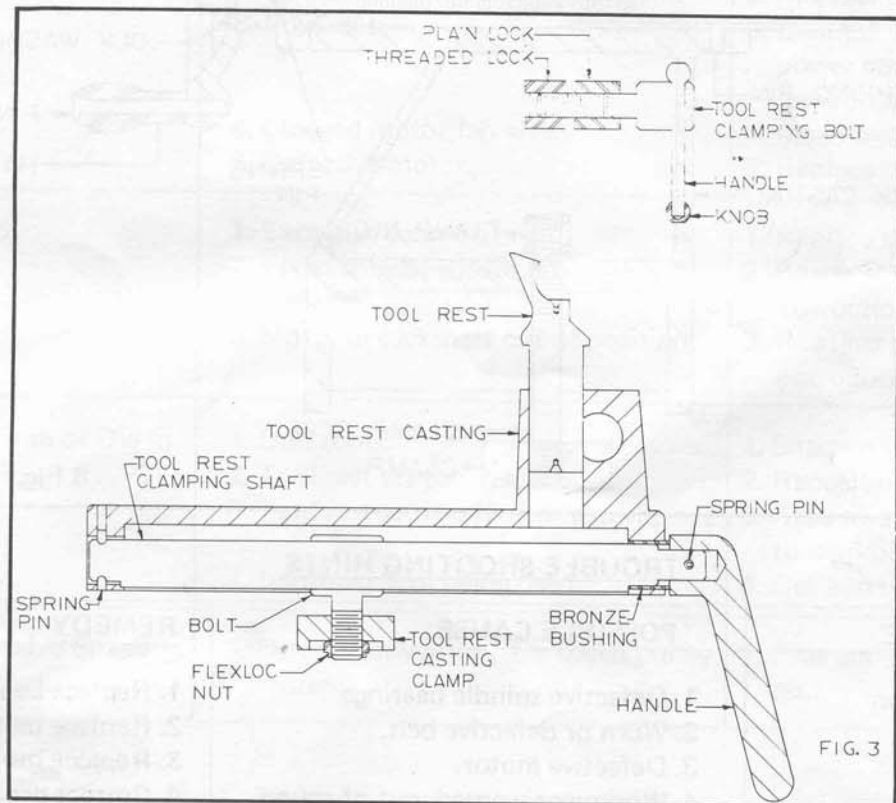

Fig. 7

LUBRICATION:

All anti-friction bearings are sealed for life and require no lubrication. The variable speed sheaves should be periodically wiped with SAE 10 oil on the male member. Other exposed parts should be lightly coated with SAE 10 oil to prevent rusting. The tailstock screw should be coated with Fiske Lubriplate 630A every ninety days. Lubriplate the clamp mechanism of the tool rest with SAE 10 oil periodically.

GENERAL INSTRUCTION, cont'd

TAILSTOCK:

The tailstock assembly shown in Figure 8 requires a minimum of service but the No. 2 Morse taper hole should be checked periodically to insure it is free of nicks and rust. The quill should be removed and the tapered socket and outside diameter wiped once a month with light machine oil. The tailstock screw and thrust bearing should be coated with Fiske Lubriplate 630A or equivalent.

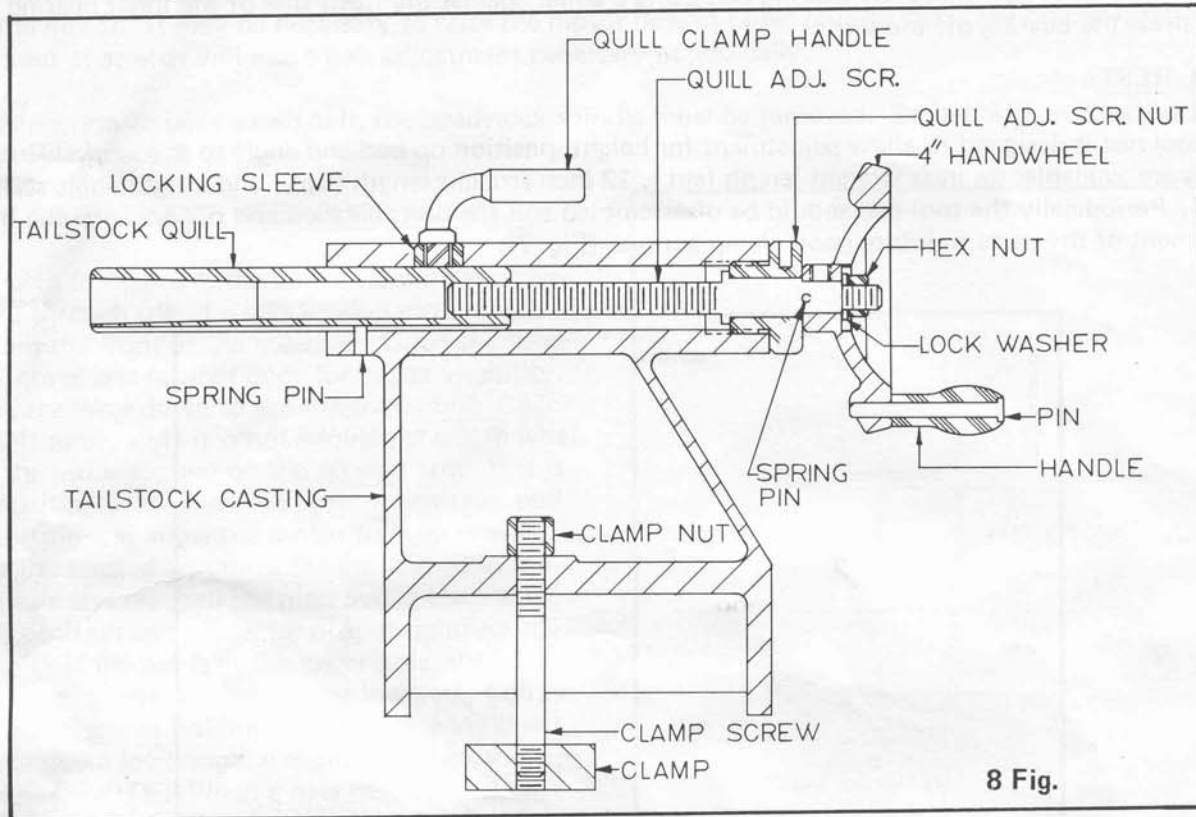

TROUBLE-SHOOTING HINTS

TROUBLE	POSSIBLE CAUSE	REMEDY
Excessive Vibration	<ol style="list-style-type: none"> 1. Defective spindle bearings. 2. Worn or defective belt. 3. Defective motor. 4. Workpiece warped, out-of-round, has major flaw, or was improperly prepared for turning. 	<ol style="list-style-type: none"> 1. Replace bearings. 2. Replace belt. 3. Replace motor. 4. Correct problem by planing or sawing, or scrap workpiece.
Motor or Spindle Stalls	<ol style="list-style-type: none"> 1. Excessive cut. 2. Defective motor. 3. Motor clogged with sawdust. 4. Excessive belt wear. 5. Improper belt adjustment. 6. Fixed sheave on spindle out of position or frozen. 7. Belt between motor and jackshaft slipping. 8. Spring loaded pulley frozen. 	<ol style="list-style-type: none"> 1. Reduce cut depth. 2. Replace motor. 3. Clean motor. 4. Replace belt. 5. Readjust belt. 6. Readjust position or lubricate sleeve with light weight oil. 7. Re-tension belt. 8. Free pulley and lubricate with silicone spray.

TROUBLE-SHOOTING HINTS, cont'd

TROUBLE	POSSIBLE CAUSE	REMEDY
Motor Overgeats	<ol style="list-style-type: none"> 1. Motor overloaded. 2. Improper cooling on motor. 	<ol style="list-style-type: none"> 1. Correct overload condition, such as reducing cut depth. 2. Clean sawdust from fan and duct areas of motor.
Motor Starts Slowly or Fails to Come up to Speed.	<ol style="list-style-type: none"> 1. Low voltage. 2. Centrifugal switch not operating. 3. Defective motor. 	<ol style="list-style-type: none"> 1. Request voltage check from power company and correct low-voltage condition. 2. Replace switch or motor. 3. Replace motor.
Motor Fails to Develop Full Power.	<ol style="list-style-type: none"> 1. Power line overloaded. 2. Undersize wires in supply system. 3. Low voltage. 4. Clogged motor fan areas. 5. Defective motor. 	<ol style="list-style-type: none"> 1. Correct overload condition. 2. Increase supply wire size. 3. Request voltage check from power company and correct low voltage condition. 4. Clean motor fan area. 5. Replace motor.
Excessive Speed	<ol style="list-style-type: none"> 1. Excessive wear on belt. 2. Fixed spindle sheave is out-of-position. 3. Motor or jackshaft out-of-position. 	<ol style="list-style-type: none"> 1. Replace belt. 2. Readjust per maintenance instructions. 3. Readjust per maintenance instructions.
Tools Tend to Grab or Dig in.	<ol style="list-style-type: none"> 1. Dull tools. 2. Tool rest set too low. 3. Tool rest set too far from workpiece. 4. Improper tool being used. 	<ol style="list-style-type: none"> 1. Sharpen tools. 2. Reposition tool rest height. 3. Reposition tool rest closer to workpiece. 4. Use correct tool for operation.
Lathe With Variable Speed Runs at One Speed.	<ol style="list-style-type: none"> 1. Drive or driven variable speed pulley frozen. 	<ol style="list-style-type: none"> 1. Free and lubricate with SAE 10 oil.

MODEL 45 LATHE - ELECTRICAL SCHEMATIC

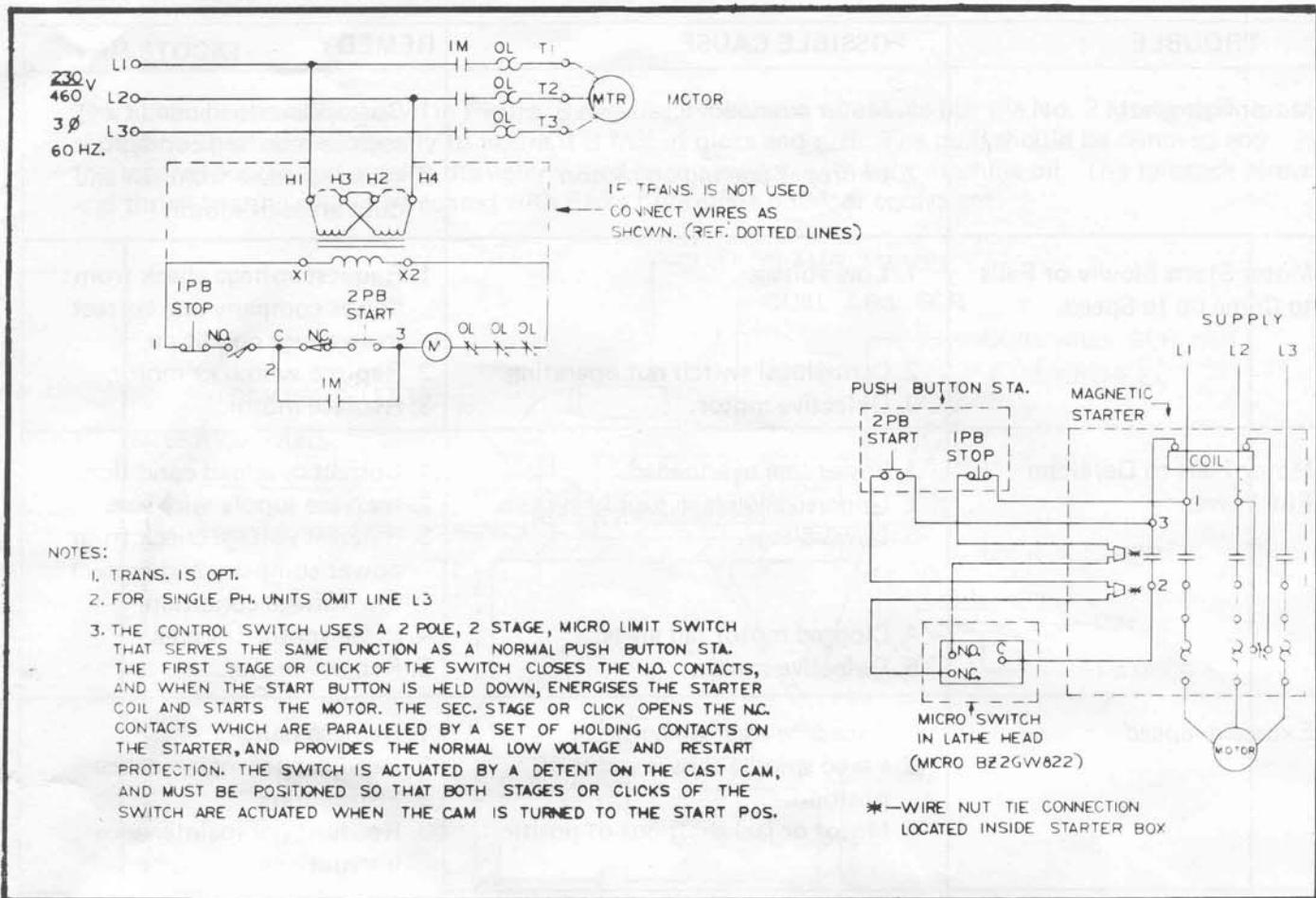

Fig. 9

MODEL 45 LATHE - ELECTRICAL SCHEMATIC PARTS LIST

ITEM NO.	PART NO.	DESCRIPTION	QTY.	ITEM NO.	PART NO.	DESCRIPTION	QTY.
ILS	6816005	SWITCH, MICRO, BZ2GW822	1	MTR.	6816126	STARTER, 3PH, W/115V TRANS. FURNAS, 14BF32BA71BA	1
IPB -	6821180	SWITCH, FURNAS, 50CA3AA	1		6470700	MOTOR, ELEC., 3/4HP, 1PH, 1800RPM, 115/230V, 56 FR. TEFC	
2PB	6821181	OPERATOR, START, FURNAS D53493001	1		6470712	MOTOR, ELEC., 3/4HP, 3PH, 1800RPM, 200V, 56 FR., TEFC	
	6821182	OPERATOR, STOP, FURNAS D22132001	1		6470707	MOTOR ELEC., 3/4HP, 3PH, 1800RPM, 230/460V, 56 FR. TEFC	
IM	6816105	STARTER, 1PH, FURNAS 14CF12BA7	1		6470702	MOTOR' ELEC., 3/4HP, 3PH, 1800RPM, 575V, 56 FR. TEFC	
	6816111	STARTER, 3PH, FURNAS 14BF32BC71					
	6816119	STARTER, 1PH, W/24v TRANS. FURNAS, 14CF107013					
	6816138	STARTER, 1PH, W/115V TRANS. FURNAS 14CF107017					
	6816122	STARTER, 3PH, W/24V TRANS. FURNAS, 14BF32BJ71BD					

MODEL 45 LATHE - SCHEMATIC, COMPOSITE ELECTRICAL

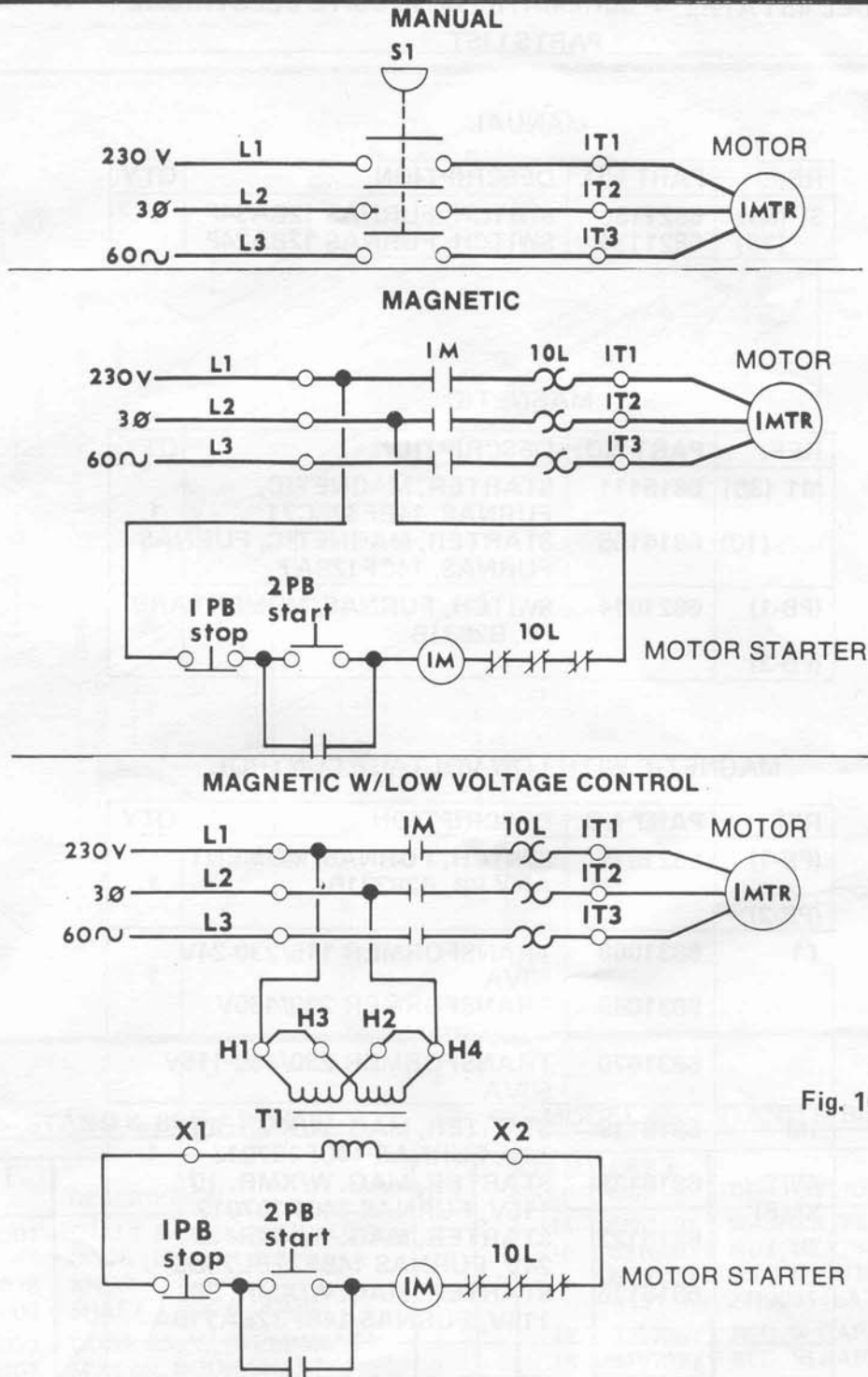
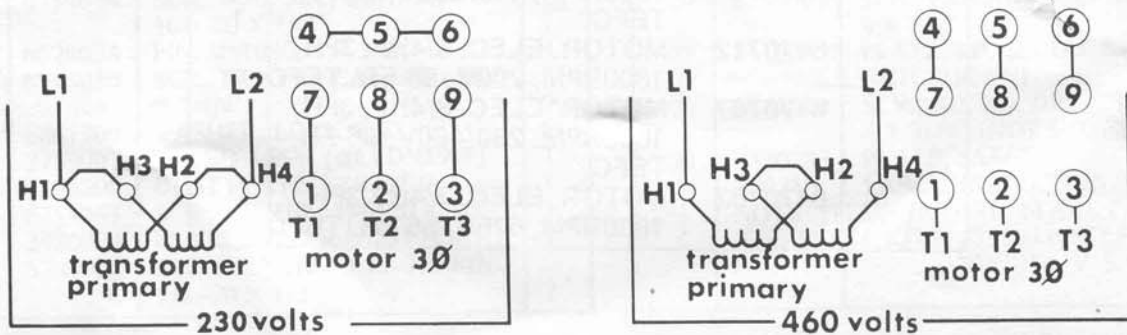

Fig. 10

NOTE: FOR SINGLE PHASE UNITS, OMIT LINE L3



**MODEL 45 LATHE - SCHEMATIC, COMPOSITE ELECTRICAL
PARTS LIST**

MANUAL

REF.	PART NO.	DESCRIPTION	QTY.
SI (30)	6821135	SWITCH, FURNAS 12BA34P	1
(10)	6821134	SWITCH, FURNAS 12BA24P	

MAGNETIC

REF.	PART NO.	DESCRIPTION	QTY.
M1 (30)	6816111	STARTER, MAGNETIC, FURNAS, 14BF32BC71	1
(10)	6816105	STARTER, MAGNETIC, FURNAS FURNAS, 14CF12BA7	
(PB-1)	6821014	SWITCH, FURNAS, MOMENTARY PB, B2831B	
(PB-2)			

MAGNETIC WITH LOW VOLTAGE CONTROL

REF.	PART NO.	DESCRIPTION	QTY.
(PB-1)	6821014	SWITCH, FURNAS, MOMENTARY PB, B28731B	1
(PB-2)			
T1	6831068	TRANSFORMER 115/230-24V 50VA	1
	6831069	TRANSFORMER 230/460V -24V, 75VA	
	6831070	TRANSFORMER 230/460-115V 50VA	
1M	6816119	STARTER, MAG. W/XMR. 10' 24V, FURNAS 14CF107013	1
/WITH XMF)	6816138	STARTER, MAG. W/XMR. 10' 115V, FURNAS 14CF107017	
	6816122	STARTER, MAG. W/XMR. 30' 24V, FURNAS 14BF32BL71BD	
	6816126	STARTER, MAG. W/XMR. 30' 115V, FURNAS 14BF32BA71BA	
MTR.	6470700	MOTOR, ELEC. 3/4HP, 1PH, 1800RPM, 115/230V, 56 FR. TEFC	1
	6470712	MOTOR, ELEC. 3/4HP, 3PH, 1800RPM, 200V, 56 FR. TEFC	
	6470707	MOTOR' ELEC. 3/4HP, 3PH, 1800RPM, 230/460V, 56 FR. TEFC	
	6470702	MOTOR, ELEC. 3/4HP 3PH, 1800RPM, 575V, 56 FR. TEFC	

MODEL 45 LATHE – STAND & BED ASSEMBLY

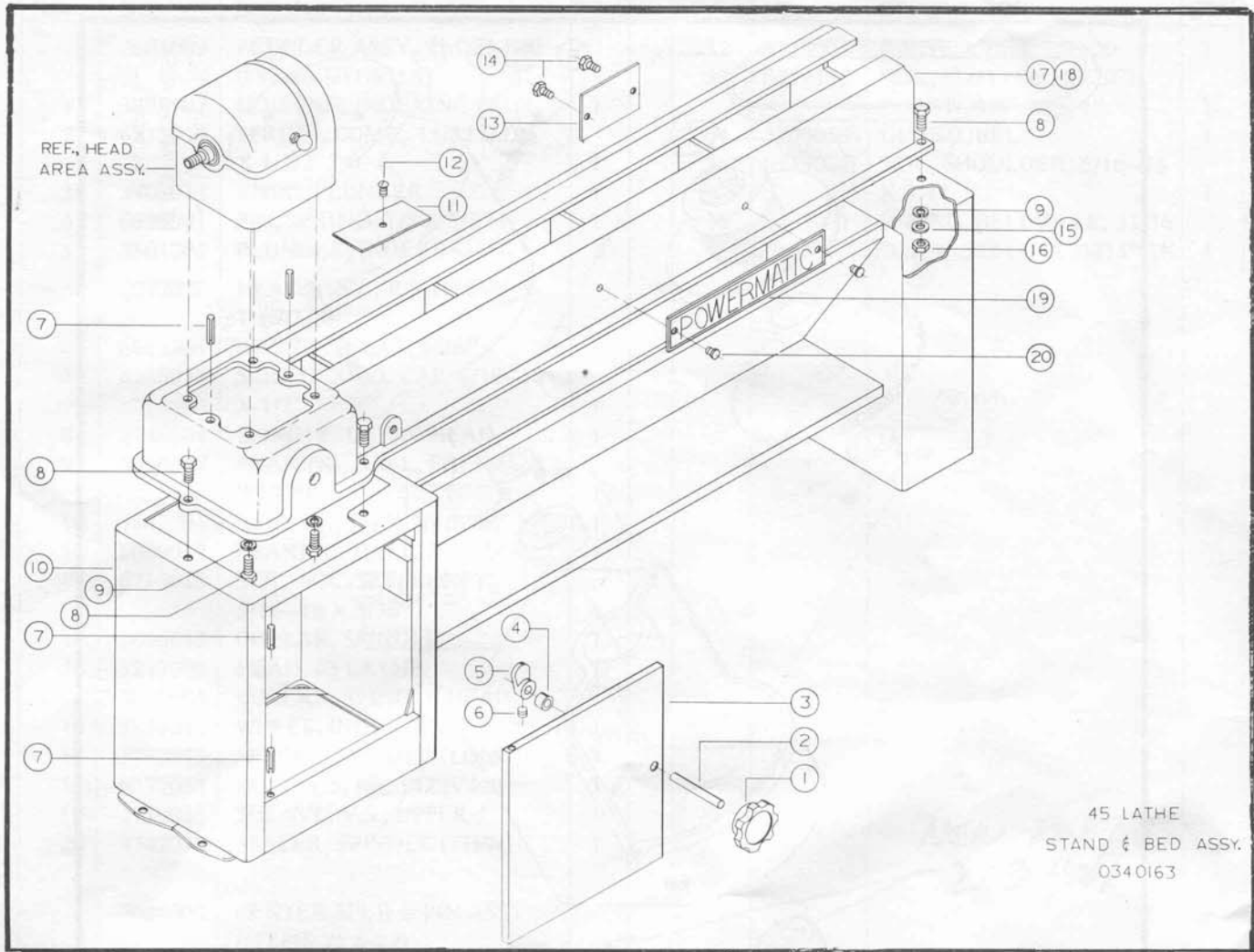

Fig. 11

MODEL 45 – STAND & BED ASSEMBLY

MODEL 45 – STAND & BED ASSEMBLY

ITEM NO.	PART NO.	DESCRIPTION	QTY.	ITEM NO.	PART NO.	DESCRIPTION	QTY.
	2708001	SHAFT & LOCK ASSY., LOWER DOOR (ITEMS 1 & 2)		15	6861301	WASHER, FLAT, 3/8"	2
1	3406018	KNOB	1	16	6516001	NUT, HEX, 3/8-16	2
2	3708002	SHAFT, LOWER DOOR	1	NOTE: ITEMS 3 THRU 16 ARE PART OF ASSY. No. 2419005 (LATHE BASIC UNIT)			
3	2136022	DOOR ASSY., (WELDMENT)	1	17	3797063	BED, W/GAP, 45 LATHE	1
4	3738201	SPACER, DOOR SHAFT	1	18	3797077	BED, STRAIGHT, 45 LATHE	1
5	3448002	LOCK, DOOR	1	19	3312226	PLATE, I.D. PLASTIC (POW.)	1
6	6714004	SCR., SOC. SET, CUP PT., 16 $\frac{1}{2}$ -20 X 1/4"	1	20	6746001	SCR., PAN HD., SELF TAPPING 6 X 1/4"	2
7	6626038	PIN, SPRING, 1/4 X 1"	4	21	33122228	PLATE, I.D. SERIAL No. (NOT SHOWN)	1
8	6716039	SCR., HEX HD. CAP, 3/8-16 X 1-1/4"	9	22	6747000	SCR., RD. HD. DRIVE 4 X 3/16" (NOT SHOWN)	2
9	6861300	WASHER, LOCK, 3/8"	6	23	3330283	PLATE, SAFETY	1
10	2759007	STAND ASSY. (WELDMENT)	1	24	340210	LABEL, INSPECTION (NOT SH.)	1
11	3596206	DUST PLATE, STR. BED	1	NOTE: ITEMS 19 THRU 24 ARE PART DECAL AND PLATE KITS: 2388032 (STEP CONE) 2388054 (V. S.)			
12	6714063	SCR., RD. HD., 1/4-20 X 1/2"	1				
13	3480004	PLATE, COVER (POST ASSY.)	1				
14	6746022	SCR., HEX HD. SELF TAPPING 1/4-20 X 1/2"	2				

MODEL 45 - V.S. HEAD AREA ASSEMBLY

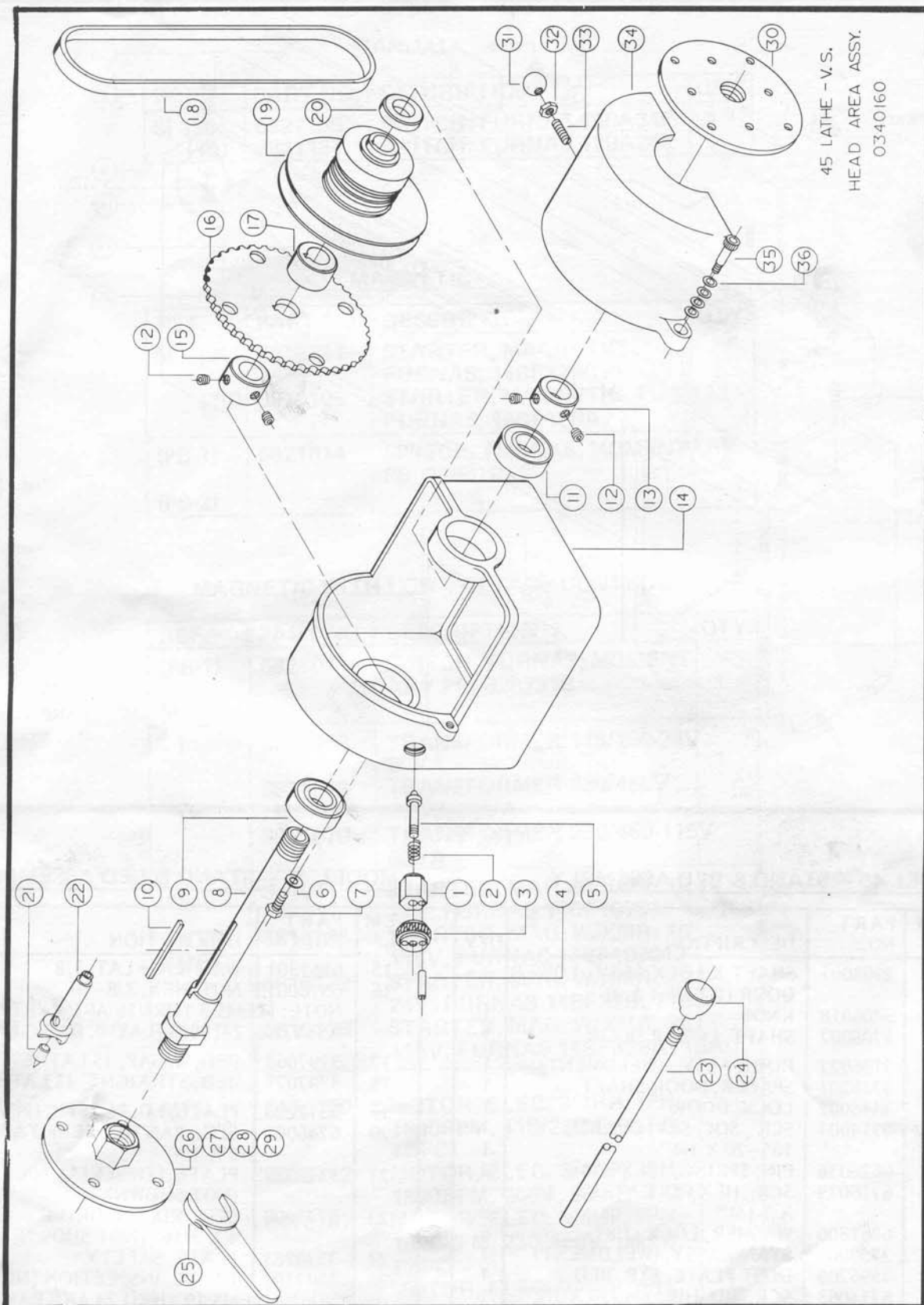

Fig. 12

MODEL 45 LATHE - V.S. HEAD AREA ASSY.

MODEL 45 LATHE - V.S. HEAD AREA ASSY.

ITEM NO.	PART NO.	DESCRIPTION	QTY.	ITEM NO.	PART NO.	DESCRIPTION	QTY.
	2601009	PLUNGER ASSY., INDEXING (ITEMS 1 THRU 5)		32	6514008	Nut, HEX JAM, 1/4-20	1
1	3298202	HOUSING, INDEXING PLGR.	1	33	6714155	SCR., SLOTTED HD. SET, CUP PT., 1/4-20 X 1"	1
2	6813016	SPRING, COMP., 15/32 O.D. X 1-1/2" I.D.	1	34	3250053	GUARD, BELT	1
3	3406013	KNOB, PLUNGER	1	35	6715064	SCR., SHOULDER, 5/16-18 X 3/4"	1
4	6626001	PIN, SPRING, 1/8 X 5/8" L	1	36	6813071	SPRING, BELLVILLE, 11/16 O.D. X .382 I.D. X .0275" TK	4
5	3601205	PLUNGER, INDEXING	1				
	2277020	HEAD ASSY., V.S. (ITEMS 6 THRU 20)					
6	6861201	WASHER, FLAT, 5/16"	1				
7	6715033	SCR., HEX HD. CAP, 5/16-18 X 1/2"	1				
8	3749004	SPINDLE, LATHE HEAD	1				
9	6060017	BEARING, BALL, FAFNIR W206PP	1				
10	3387004	KEY, SQ., 1/4 X 1/4 X 4"	1				
11	6060012	BEARING, BALL, R-16ZZ MRC	1				
12	6715016	SCR., SOC. SET, CUP PT., 5/16-18 X 5/16"	4				
13	3096015	COLLAR, SPINDLE	1				
14	3277009	HEAD, 45 LATHE	1				
15	3096005	COLLAR, SPINDLE HEAD	1				
16	3850010	WHEEL, INDEXING	1				
17	3742013	SPACER, SPINDLE (LONG)	1				
18	6077051	BELT, V.S. No. 1422V420	1				
19	2719013	SHEAVE, V.S., UPPER	1				
20	3742010	SPACER, SPINDLE (THIN)	1				
	2084001	CENTER SPUR & PIN ASSY., (ITEMS 21 & 22)					
21	3582202	PIN, CENTER	1				
22	3081201	CENTER, SPUR, 1" No. 924	1				
	2670008	ROD ASSY., KNOCKOUT (ITEMS 21 & 22)					
23	3670021	ROD, KNOCKOUT	1				
24	3406201	KNOB, TEARDROP	1				
25	6960039	WRENCH, FACE PLATE, 45 LATHE (STANDARD)	1				
26	3193001	3" FACE PLATE, RIGHT HAND (OPTIONAL)	1				
27	3193003	4" FACE PLATE RIGHT HAND (OPTIONAL)	1				
28	3193006	6" FACE PLATE, RIGHT HAND (STANDARD)	1				
29	3193007	8" FACE PLATE, RIGHT HAND (OPTIONAL)	1				
30	3193016	8-1/2" FACE PLATE, LEFT HAND (OUTBOARD; OPTIONAL)	1				
31	3406208	KNOB, ROUND	1				

*NEW PART NO.
208 4001*

3

MODEL 45 - STEP CONE HEAD AREA ASSEMBLY

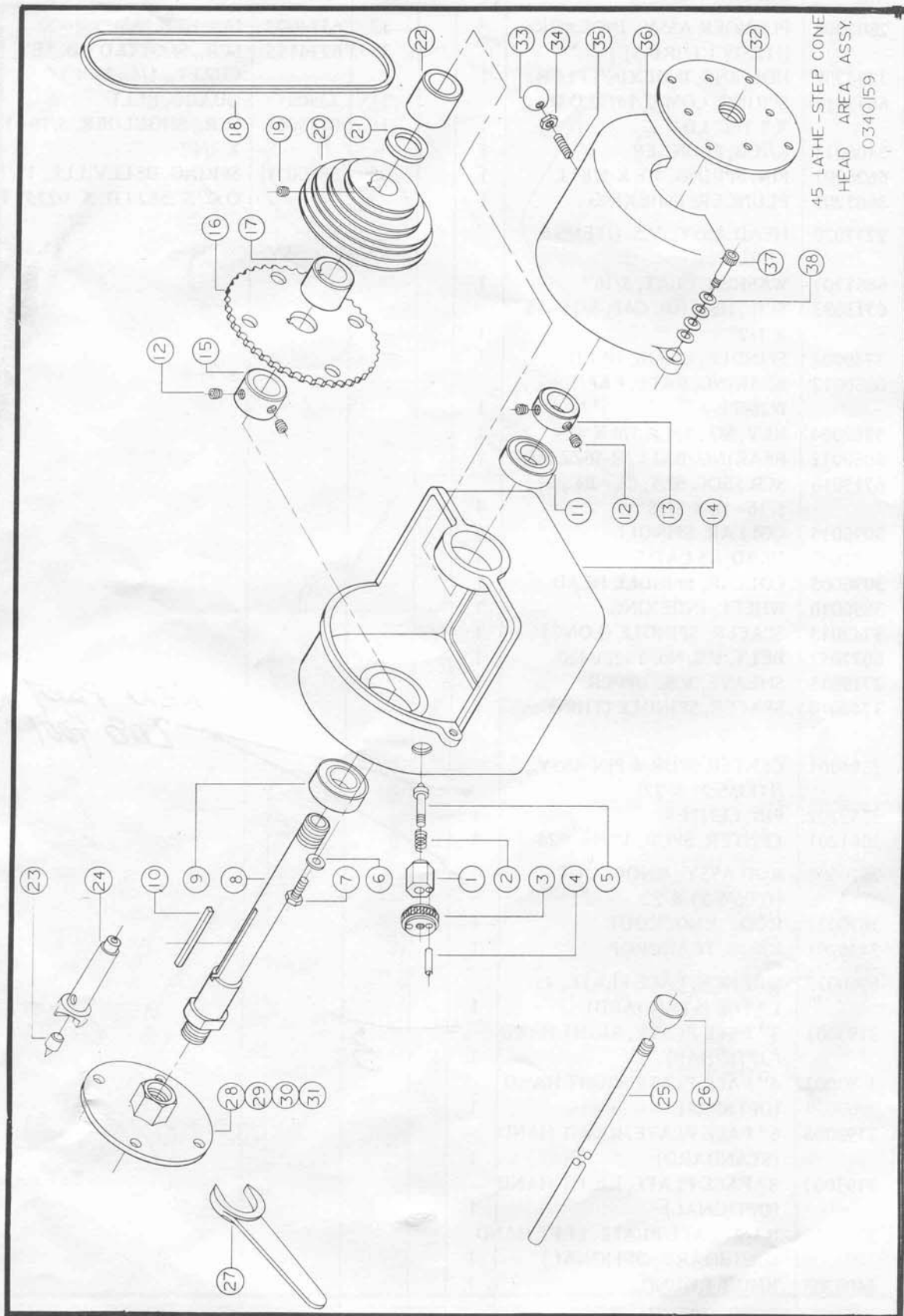
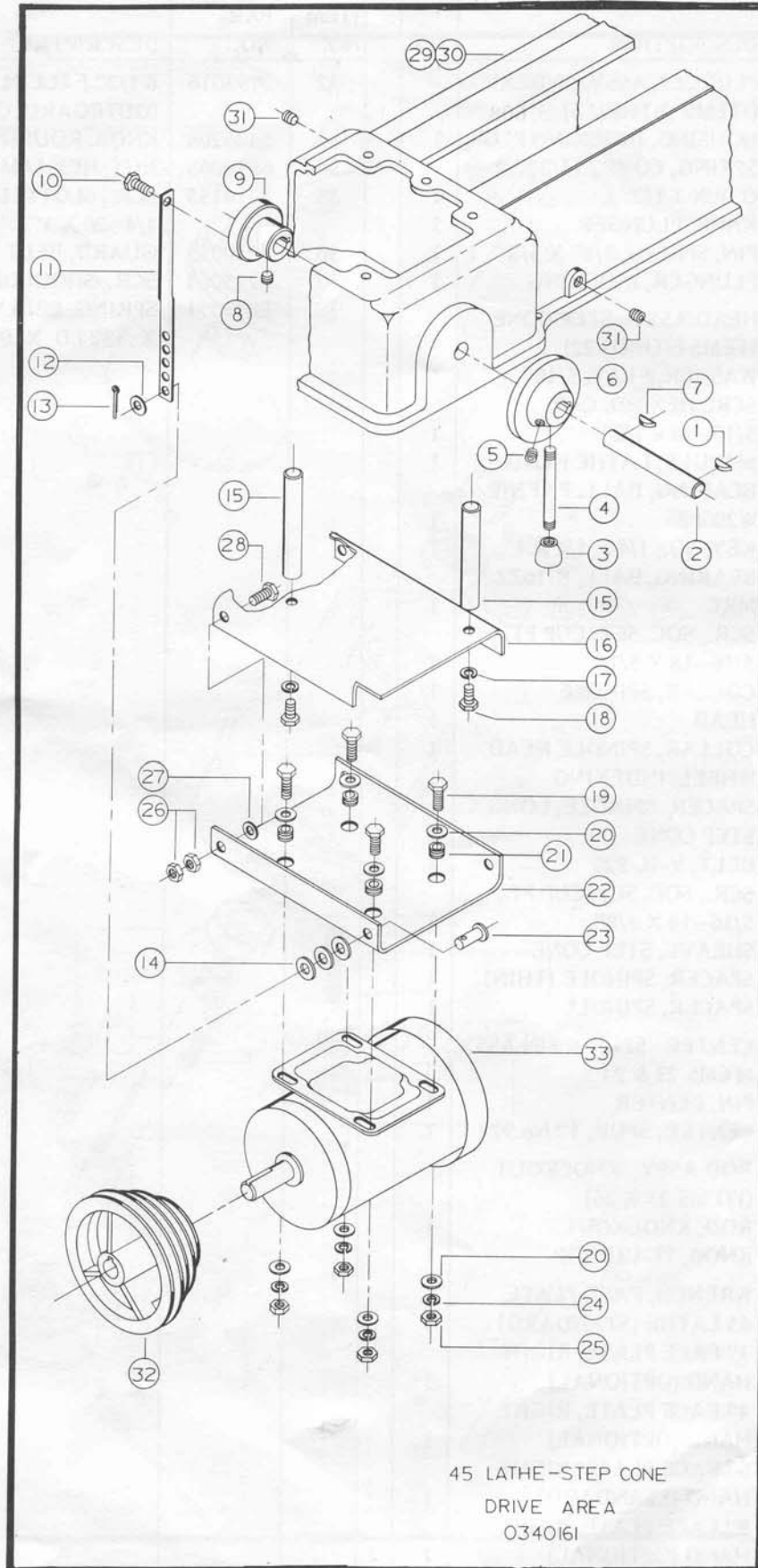

Fig. 13

MODEL 45 - STEP CONE HEAD AREA ASSEMBLY

ITEM NO.	PART NO.	DESCRIPTION	QTY.	ITEM NO.	PART NO.	DESCRIPTION	QTY.
	2601009	PLUNGER ASSY., INDEXING (ITEMS 1 THRU 5)		32	3193016	8-1/2" FACE PLATE, LEFT HAND (OUTBOARD; OPTIONAL)	1
1	3298202	HOUSING, INDEXING PLGR.	1	33	3406208	KNOB, ROUND	1
2	6813016	SPRING, COMP., 15/32" O'D. X 1-1/2" L	1	34	6514008	NUT, HEX JAM, 1/4-20	1
3	3406013	KNOB, PLUNGER	1	35	6714155	SCR., SLOTTED HD. SET, CUP PT., 1/4-20 X 1"	1
4	6626001	PIN, SPRING, 1/8" X 5/8" L	1	36	3250053	GUARD, BELT	1
5	3601206	PLUNGER, INDEXING	1	37	6715064	SCR., SHOULDER, 5/16-18 X 3/4"	1
	2277002	HEAD ASSY., STEP CONE (ITEMS 6 THRU 22)		38	6813071	SPRING, BELLVILLE, 11/16 O.D. X .382 I.D. X .0275 THK.	4
6	6861201	WASHER, FLAT, 5/16"	1				
7	6715033	SCR., HEX HD. CAP, 5/16-18 x 1/2"	1				
8	3749004	SPINDLE, LATHE HEAD	1				
9	6060017	BEARING, BALL, FAFNIR W206PP	1				
10	3387004	KEY, SQ., 1/4 X 1/4 X 4"	1				
11	6060012	BEARING, BALL, R-16ZZ MRC	1				
12	6715016	SCR., SOC. SET, CUP PT., 5/16-18 X 5/16"	4				
13	3096015	COLLAR, SPINDLE	1				
14	3277009	HEAD	1				
15	3096005	COLLAR, SPINDLE HEAD	1				
16	3850010	WHEEL, INDEXING	1				
17	3742001	SPACER, SPINDLE, LONG STEP CONE	1				
18	6077024	BELT, V-4L-520	1				
19	6715013	SCR., SOC. SET, CUP PT., 5/16-18 X 3/8"	1				
20	3718002	SHEAVE, STEP CONE	1				
21	3742011	SPACER, SPINDLE (THIN)	1				
22	3742012	SPACER, SPINDLE	1				
	2084001	CENTER SPUR & PIN ASSY., (ITEMS 23 & 24)					
23	3582202	PIN, CENTER	1				
24	3081202	CENTER, SPUR, 1" No.924	1				
	2670008	ROD ASSY., KNOCKOUT (ITEMS 25 & 26)					
25	3670021	ROD, KNOCKOUT	1				
26	3406201	KNOB, TEARDROP	1				
27	6960039	WRENCH, FACE PLATE 45 LATHE (STANDARD)	1				
28	3193001	3" FACE PLATE, RIGHT HAND (OPTIONAL)	1				
29	3193003	4" FACE PLATE, RIGHT HAND (OPTIONAL)	1				
30	3193006	6" FACE PLATE, RIGHT HAND (STANDARD)	1				
31	3193007	8" FACE PLATE, RIGHT HAND (OPTIONAL)	1				

MODEL 45 LATHE – STEP CONE DRIVE AREA



MODEL 45 – STEP CONE DRIVE AREA

MODEL 45 – STEP CONE DRIVE AREA

ITEM NO.	PART NO.	DESCRIPTION	QTY
	2698007	SELECTOR ASSY., 4 SPEED (ITEMS 1 THRU 6)	
1	6420002	KEY, WOODRUFF No. 608	1
2	3703001	SHAFT, CAM	1
3	3406020	KNOB, SPEED SELECTOR	1
4	3709009	SHAFT, SPEED SELECTOR	1
5	6716003	SCR., SOC. SET, CUP PT., 3/8-16 X 3/8"	1
6	3406201	KNOB, SPEED SELECTOR	1
	2445002	LINKAGE ASSY., BELT TENS. (ITEMS 7 THRU 14)	
7	6420002	KEY, WOODRUFF no' 608	1
8	6715013	SCR., SOC. SET, CUP PT., 5/16-18 X 3/8"	1
9	3076007	CAM, BELT TENSION	1
10	6715035	SCR., HEX HD. CAP, 5/16-18 X 3/4"	1
11	3025007	ARM, BELT TENSION	1
12	6861101	WASHER, FLAT, 1/4"	1
13	6622009	PIN, COTTER, 3/32 X 1-1/4 X 3/16"	1
14	3741201	SPACER, RUBBER, 7/16 I.D. X 1 O.D. X 1/8" THICK	3
	20422007	BASE ASSY., MOTOR STEP CONE (ITEMS 15 THRU 28)	
15	3670020	ROD, MOTOR BASE ADJUST.	2
16	3063066	MOUNTING BRACKET, MOTOR BASE	1
17	6861300	WASHER, LOCK, 3/8"	2
18	6716031	SCR., HEX HD. 3/8-16 X 1" (FOR ROD, MOTOR BASE ADJ.)	2
19	6715032	SCR., HEX HD. CAP, 5/16-18 X 1"	4
20	6861201	WASHER, FLAT, 5/16"	8
21	6336000	GROMMET, BLACK RUBBER 5/16"	4
22	3042023	BASE, MOTOR	1
23	3584001	PIN, PIVOT, 5/16 DIA. X 1" L	1
24	6861200	WASHER, LOCK, 5/16"	4
25	6515001	NUT, HEX, 5/26"	4
26	6516009	NUT, HEX JAM, 3/8-16	4
27	6861301	WASHER, FLAT, 3/8"	1
28	6716039	SCR., HEX HD. CAP, 3/8-16 X 1-1/4"	2
29	3797077	BED, STRAIGHT, 45 LATHE	1
30	3797063	BED, W/GAP, 45 LATHE	1
31	6716003	SCR., SOC. SET, CUP PT., 3/8-16 X 3/8"	2
32	6807083	SHEAVE, STEP CONE, Browning, SCZ3 – 5/8" BORE	1

ITEM NO.	PART NO.	DESCRIPTION	QTY.
33	6470700	MOTOR, ELEC., 3/4HP, 1PH, 1800RPM, 115/230V, 56 FR. TEFC	1
	6470702	MOTOR, ELEC., 3/4HP, 3PH, 1800RPM, 575V, 56 FR. TEFC	1
	6470707	MOTOR, ELEC., 3/4HP, 3PH, 1800RPM, 230/460V, 56 FR. TEFC	1
	7470712	MOTOR, ELEC., 3/4HP, 3PH, 1800RPM, 200V, 56 FR. TEFC	1

MODEL 45 - VARIABLE SPEED DRIVE AREA

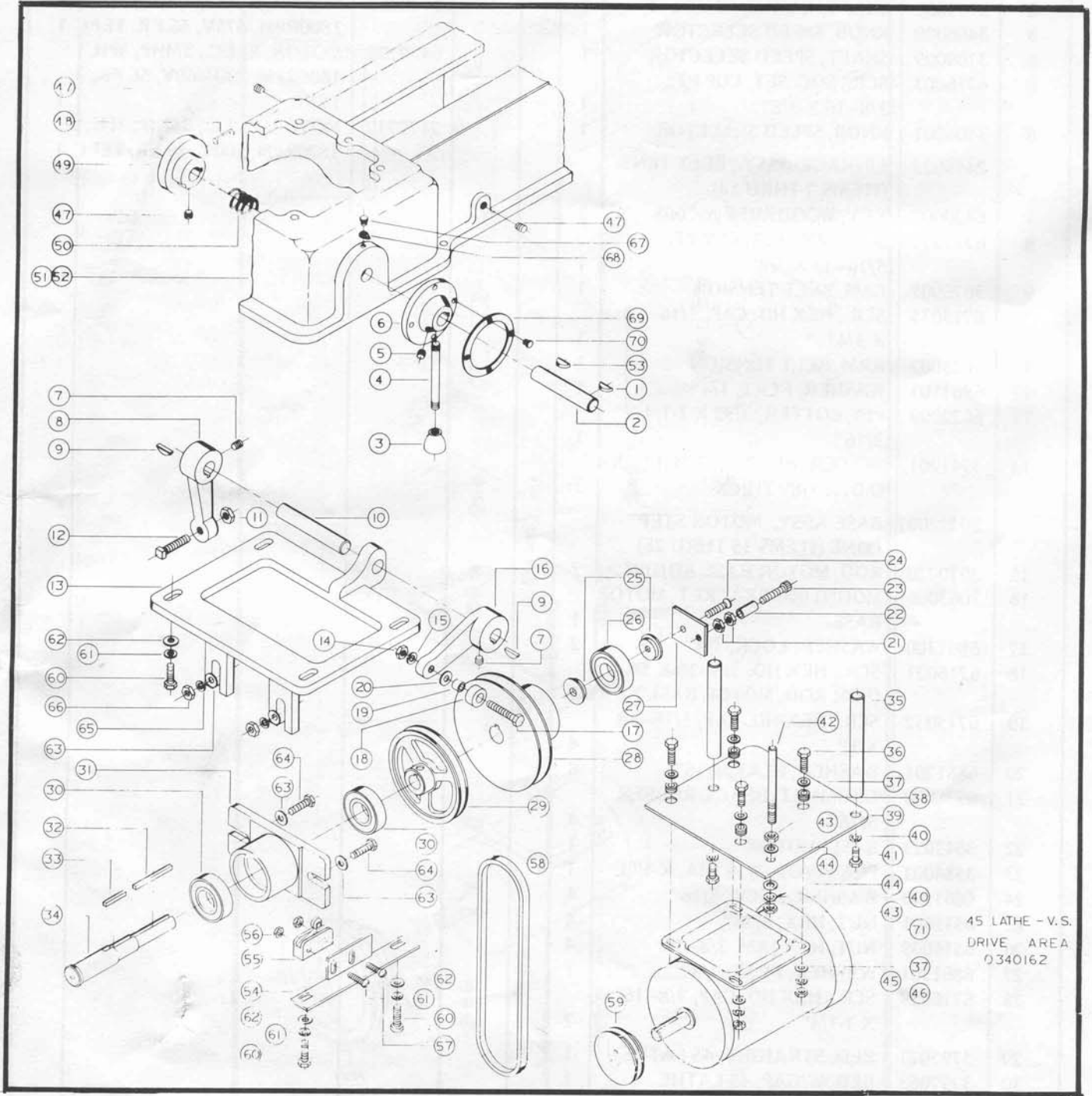

45 LATHE - V.S.
DRIVE AREA
0340162

Fig. 15

MODEL 45 - V.S. DRIVE AREA

MODEL 45 - V.S. DRIVE AREA

ITEM NO.	PART NO.	DESCRIPTION	QTY.
	2698003	SELECTOR ASSY., V.S. (ITEMS 1 THRU 6)	
1	6420002	KEY, WOODRUFF No. 608	1
2	3703001	SHAFT, CAM	1
3	3406201	KNOB, SPEED SELECTOR	1
4	3709009	SHAFT, SPEED SELECTOR	1
5	6716003	SCR., SOC. SET, CUP PT., 3/8-16 X 3/8"	1
6	3406019	KNOB, SPEED SELECTOR	1
	2063014	BRACKET ASSY., V.S. W/MICRO SWITCH (ITEMS 7 THRU 20)	
7	6715016	SCR., SOC. SET, CUP PT., 5/16-18 X 5/16"	2
8	3025006	ARM, PIVOT, V.S.	1
9	6420002	KEY, WOODRUFF No. 608	2
10	3703002	SHAFT, CAM ARM	1
11	6518008	NUT, HEX JAM, 1/2-13	1
12	6718046	SCR., SQ. HD., 1/2-13 X 1-3/4"	1
13	3063067	BRACKET, V.S. MOUNTING	1
14	6515007	NUT, HEX JAM, 5/16-18	1
15	6861200	WASHER, LOCK, 5/16"	1
16	3025027	ARM, V.S. CAM	1
17	6715037	SCR., HEX HD., 5/16-18 X 1-1/2"	1
18	3673032	ROLLER, V.S. CAM	1
19	6095043	BUSHING, PS-R 306 X 3/8"	1
20	6861201	WASHER, FLAT, 5/16"	1
	2298030	HOUSING ASSY., V.S. LOWER SHEAVE (ITEMS 21 THRU 34)	
	2595003	PLATE ASSY., V.S. BEARING (ITEMS 21 THRU 27)	
21	6514011	NUT, HEX JAM, 1/4-20 (PLTD)	2
22	3070201	BUSHING, BLACK RUBBER BUMPER, 1/4 I.D. X 1/2 O.D. X 1" LG.	1
23	6714040	SCR., FILLISTER HD. MACH., 1/4-20 X 1-1/2"	1
24	6714056	SCR., FLAT HD. MACH., 1/4-20 X 1"	1
25	3598005	PLUG, V.S. BEARING	2
26	6060013	BEARING, BALL, FAFNIR No. 9106NPP	1
27	3595005	PLATE, BEARING	1
28	2719008	SHEAVE ASSY., V.S. LOWER	1
29	6807040	SHEAVE, BROWNING AK-54, 7/8" BORE	1
30	6060010	BEARING, BALL, FAFNIR No. 205NPP	2
31	3298016	HOUSING, V.S. SHAFT, LOWER	1
32	3388015	KEY, SQ., 3/16 X 3/16 X 2-1/4"	1
33	3388004	KEY, SQ., 3/16 X 3/16 X 1"	1
34	3704035	SHAFT, LOWER V.S.	1
	2042006	BASE ASSY., V.S. MOTOR (ITEMS 35 THRU 46)	
35	3670051	ROD, V.S. MOTOR BASE	2
36	6715032	SCR., HEX HD. CAP, 5/16-18 X 1"	4
37	6861201	WASHER, FLAT, 5/16"	8
38	6336000	GROMMET, BLACK RUBBER	4
39	3042022	BASE, MOTOR	1
40	6861300	WASHER, LOCK, 3/8"	3

ITEM NO.	PART NO.	DESCRIPTION	QTY.
41	6716031	SCR., HEX HD. CAP, 3/8-16 X 1"	2
42	3691009	SCR., JACK, MOTOR BASE	1
43	6516001	NUT, HEX, 3/8-16	2
44	6861301	WASHER, FLAT, 3/8"	2
45	6861200	WASHER, LOCK, 5/16"	4
46	6515007	NUT, HEX JAM, 5/16-18	4
47	6716003	SCR., SOC. SET, CUP PT., 3/8-16 X 3/8"	3
48	6626029	PIN, SPRING, 3/16 X 1"	1
49	3076008	CAM, MICRO SWITCH	1
50	6813033	SPRING, COMP.; No. 18156	1
51	3797077	BED, STRAIGHT, 45 LATHE	1
52	3797063	BED, W/GAP, 45 LATHE	1
53	6420002	KEY, WOODRUFF No. 608	1
54	3062007	BRACKET, MICRO SWITCH MOUNTING	1
55	6816005	SWITCH, MICRO No. BZ2G822	1
56	6506001	NUT, HEX, No. 6-32	2
57	6706043	SCR., ROUND HD. MACH., 6-32 X 1"	2
58	6077007	BELT, "V" - 4L280	1
59	6807027	SHEAVE, BROWNING, AK-25 5/8" BORE (MOTOR)	1
60	6716032	SCR., HEX HD. CAP, 3/8-16 X 1-1/2"	4
61	6861300	WASHER, LOCK, 3/8"	4
62	6861301	WASHER, FLAT, 3/8"	4
63	6861401	WASHER, FLAT, 7/16"	4
64	6717016	SCR., HEX HD. CAP, 7/16-14 X 2"	2
65	6861400	WASHER, LOCK, 7/16"	2
66	6517006	NUT, HEX JAM, 7/16"	2
NOTE: ITEMS 47 THRU 66 ARE PART OF ASSY. Nos. 2419018 & 2419019 (LATHE, BASIC UNIT, V.S.)			
67	6746001	SCR., PAN HD. SELF TAPPING 6 X 1/4"	1
68	3604008	POINTER	1
69	3747217	PLATE, SPEED, V.S.	1
70	6747000	SCR., RD. HD. DRIVE 4 X 3/16"	4
NOTE: ITEMS 67 THRU 70 ARE PART OF ASSY. No. 2388054 (KIT, PLATE, V.S.)			
71	6470700	MOTOR, ELEC., 3/4HP, 1PH, 1800RPM, 115/230V, 56 FR. TEFC	1
	6470702	MOTOR, ELEC., 3/4HP, 3PH, 1800RPM, 575V, 56 FR, TEFC	1
	6470707	MOTOR, ELEC., 3/4HP, 3PH, 1800RPM, 230/460V, 56 FR. TEFC	1
	6470712	MOTOR, ELEC., 3/4HP, 3PH, 1800RPM, 200V, 56 FR. TEFC	1

MODEL 45 LATHE – TAILSTOCK ASSEMBLY

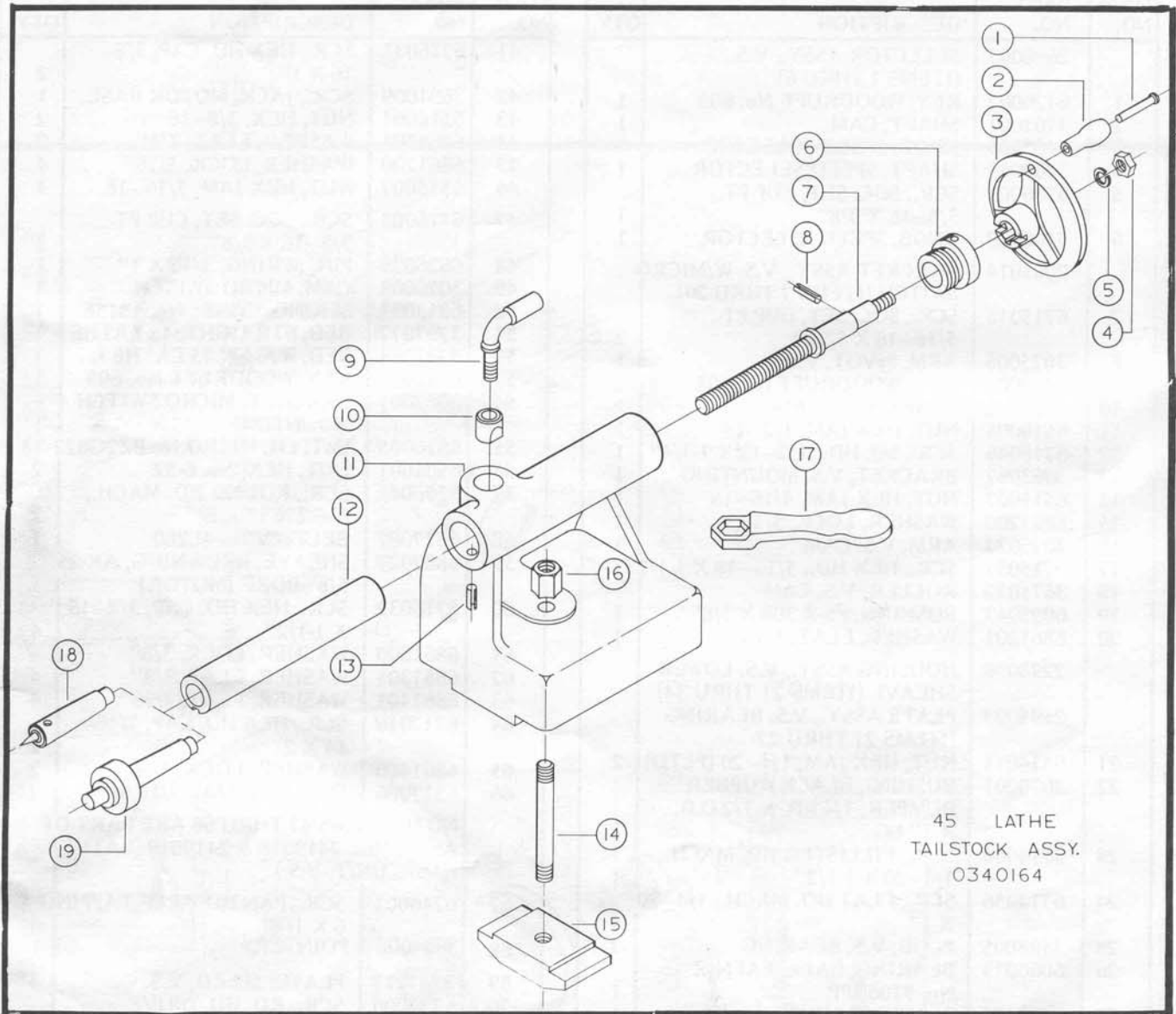

45 LATHE
TAILSTOCK ASSY.
0340164

Fig. 16

MODEL 45 – TAILSTOCK ASSEMBLY

MODEL 45 – TAILSTOCK ASSEMBLY

ITEM NO.	PART NO.	DESCRIPTION	QTY.	ITEM NO.	PART NO.	DESCRIPTION	QTY.
	2800001	TAILSTOCK ASSY. (ITEMS 1 THRU 13)		10	3728005	SLEEVE, QUILL LOCK	1
	2271017	HANDWHEEL ASSEMBLY (ITEMS 1 THRU 3)		11	3799001	TAILSTOCK, L-103	1
1	6624006	PIN, GROOVE, 1/4 X 3"	1	12	3640001	QUILL, TAILSTOCK	1
2	3268201	HANDLE, NYLON	1	13	6626028	PIN, SPRING, 3/16 X 1/2"	1
3	3271048	HANDWHEEL, 4" DIA.	1		2092003	CLAMP ASSY., TAILSTOCK (ITEMS 14 & 15)	
4	6516001	NUT, HEX, 3/8-16	1	14	3695030	SCREW, LOCK	1
5	6861300	WASHER, LOCK, 3/8"	1	15	3092004	CLAMP, TAILSTOCK	1
6	3530001	NUT, QUILL ADJ. SCREW	1	16	3526204	NUT, HEX, TAILSTOCK, SP.	1
7	3690013	SCREW, QUILL ADJUST	1	17	3868001	WRENCH, TAILSTOCK	1
8	6626005	PIN, SPRING, 1/8 X 7/8"	1	18	6112002	CENTER, CUP No. 2 M.T.	
9	3268001	HANDLE, TAILSTOCK QUILL CLAMP	1			SHANK W/CENTER	1
				19	6112004	CENTER, LIVE, BALL BRG.	1

MODEL 45 LATHE – TOOL REST ASSEMBLY

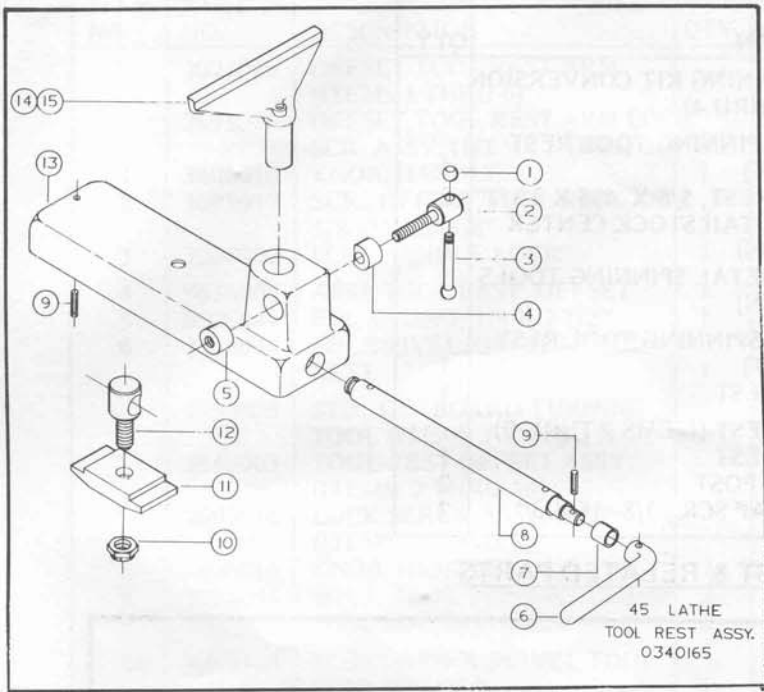

Fig. 17

ITEM NO.	PART NO.	DESCRIPTION	QTY.
	2440003	LOCK ASSY, TOOL REST (ITEMS 1 THRU 5)	
	2695016	SCREW ASSY., LOCK (ITEMS 1 THRU 3)	
1	3406016	KNOB, HANDLE	!
2	3058005	BOLT, TOOL SUPPORT CLP.	1
3	3268002	HANDLE	1
4	3448008	LOCK, TOOL REST, PLAIN	1
5	3448009	LOCK, TOOL REST, THRD.	1
	2063011	BRACKET ASSY., TOOL REST (ITEMS 6 THRU 13)	
6	3268003	HANDLE, TOOL REST	1
7	6095038	BUSHING, BRONZE, 7/8 I.D. X 1" O.D. X 7/8" LG.	1
8	3708006	SHAFT, TOOL REST CLPNG.	1
9	6626032	PIN, SPRING, 3/16 X 1-1/4"	2
10	6520009	NUT, HEX, LOCK, 5/8-11 THIN HEIGHT, FLEXLOC	1
11	3092005	CLAMP, TOOL REST	1
12	3058001	BOLT, TOOL SUPPORT CLP.	1
13	3658001	REST, TOOL	1
14	3658010	TOOL REST, 6"	1
15	3658009	TOOL REST, 12"	1

MODEL 45 LATHE – GUARD ASSEMBLY

ITEM NO.	PART NO.	DESCRIPTION	QTY.
1	3578240	PANEL, FRONT RIGHT	1
2	3578239	PANEL, FRON LEFT	!
3	3578242	PANEL, END	1
4	6715032	SCR., HEX HD., 5/16-18 X 1"	6
5	3063289	BRACKET, MOUNTING END	1
6	3063288	BRACKET, MOUNTING LATCH	1
7	3063287	BRACKET, MOUNTING	1
8	3578241	PANEL, REAR	1

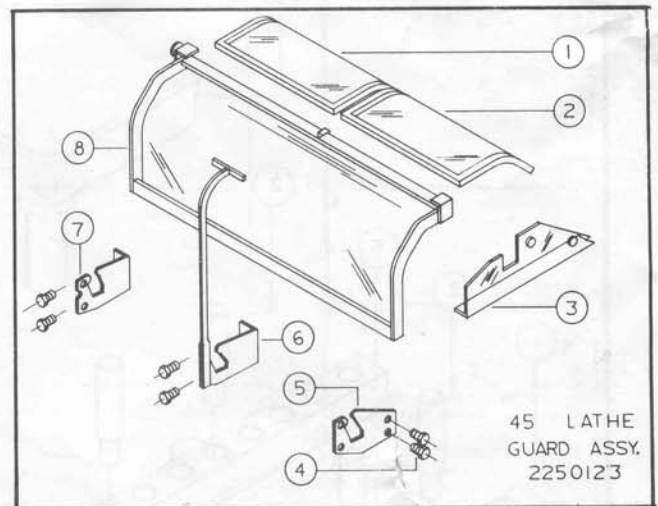

Fig. 18

**MODEL 45 LATHE – TOOL REST & RELATED PARTS
(OPTIONAL)**

ITEM NO.	PART NO.	DESCRIPTION	QTY.
	2397009	METAL SPINNING KIT CONVERSION (ITEMS 1 THRU 4)	
1	2658001	6" METAL SPINNING TOOL REST (WELDMENT)	1
2	3585011	PIN, TOOL REST, 5/8 X .495 X 3-1/2"	2
3	6112004	BALL BRG., TAILSTOCK CENTER (NOT SHOWN)	1
4	6829013	SET OF 6, METAL SPINNING TOOLS (NOT SHOWN)	
5	2658002	12" METAL SPINNING TOOL REST (WELDMENT)	1
6	3658007	90° TOOL REST	1
7	2658007	24" TOOL REST (ITEMS 7 THRU 9)	1
8	3658006	24" TOOL REST	1
9	3607001	TOOL REST POST	2
	6716020	SOC., HD. CAP SCR., 3/8-16 X 3"	2

MODEL 45 TOOL REST & RELATED PARTS

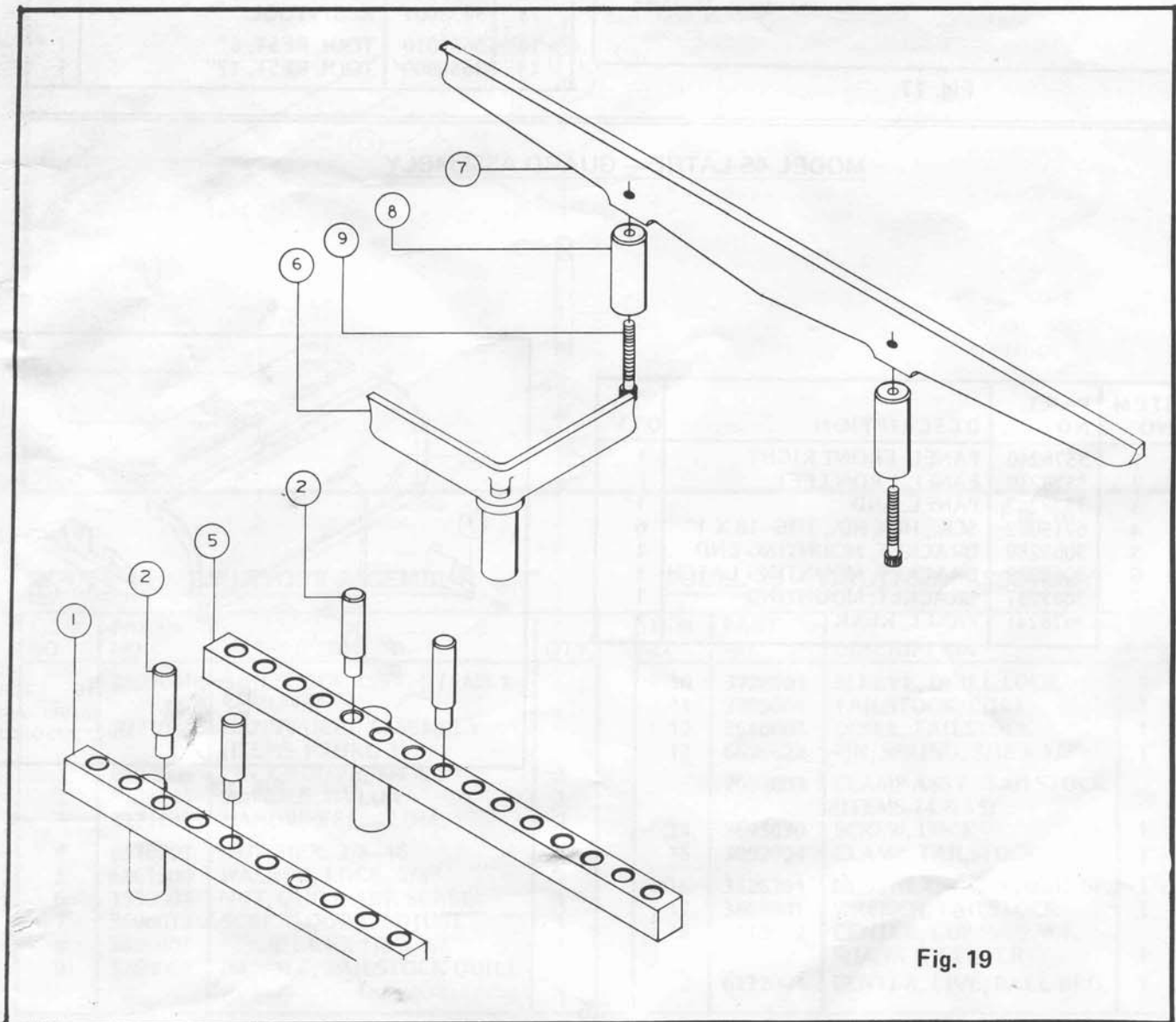

Fig. 19

**MODEL 45 LATHE – OUTBOARD TURNING PARTS ASSEMBLY
(OPTIONAL)**

ITEM NO.	PART NO.	DESCRIPTION	QTY.
	2025016	OFFSET TOOL REST ARM (ITEMS 1 THRU 6)	
	2695026	OFFSET TOOL REST ARM LOCK SCR. ASSY. (ITEMS 1 THRU 3)	
1	3406016	KNOB, HANDLE	1
2	3695017	SCR., OFFSET TOOL REST ARM 5/8-18 X 2-5/8"	1
3	3268002	SCR., HANDLE LOCK	1
4	3658006	ARM, TOOL REST, OFFSET	1
5	6626044	PIN, SPRING, 1/4 X 2-1/2"	1
6	3584014	PIN, SWIVEL, OFFSET TOOL REST	1
	2759009	STD., OUTBOARD TURNING TOOL (ITEMS 7 THRU 13)	
	2658003	TOOL REST OFFSET ASSY. (ITEMS 7 THRU 10)	
	2695016	LOCK SCREW ASSEMBLY (ITEMS 7 THRU 9)	
7	3406016	KNOB, HANDLE	2
8	3058005	BOLT, TOOL SUPPORT CLAMP	2
9	3268002	SCR., HANDLE LOCK	2
10	3289018	OUTBOARD & SWIVEL TOOL REST HOLDER	1
11	2096035	COLUMN ASSY. (WELDMENT)	1
12	6718034	SCR., SOC. 1/2 DOG PT., 1/2-13 X 1/2"	1
13	3042063	STAND BASE, TOOL REST	1

MODEL 45 OUTBOARD TURNING STAND

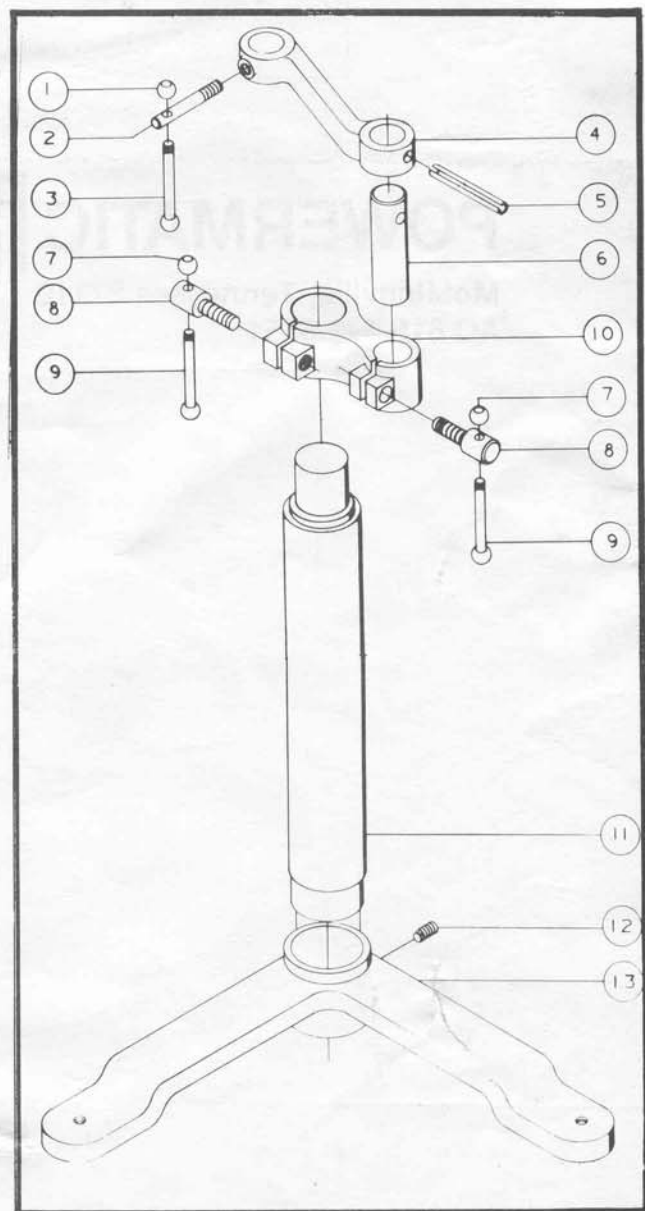

Fig. 20